

40 interior

sliding folding room divider sets

No bottom track

3 Door Set

1.8M - 1790mm W x 2054mm H

2.1M - 2090mm W x 2054mm H

2.4M - 2390mm W x 2054mm H

Assembly
Instructions



About your folding sliding internal room divider set

All products must be installed in accordance with accepted good trade practice (and in accordance with supplied instructions where applicable), and maintained in accordance with these procedures or else the warranty shall be void.

Important information

- We recommend that a competent tradesperson install this product.
- A single person must *never* carry out the installation, as some components are very heavy.
- The Outer-Frame Head requires fixing to the building lintel over the opening. The lintel *must* be capable of carrying the load of the door in all conditions. If in doubt consult a structural engineer.

Automatic Closures and Operators

- The hardware systems are designed for manual operation. Poorly adjusted automatic operator closers can impart significant destructive forces to tracks, bearings and stops. Such hardware used in installations is expressly excluded from warranty terms.

Care of doors and frames on site

- Please check doors, frame and cill at the time of delivery to ensure that they are acceptable and in good condition, and within 72 hours of delivery. If you find a component missing or damaged please inform us immediately. We keep replacement components of most set parts and these can be sent out to you quickly. This will save you having to re-package and return the whole set, and allows you to continue with the project. (See separate parts list for component reference numbers)
- When storing prior to installation, the doors and frames should be handled with care and stored in a dry, ventilated building. Doors and frames should be stored flat and on a level surface (not on edge or on end).
- Should you need to store the doors before installation, they must still be fully inspected and checked for damage or faults and reported within 72 hours of delivery, repacking if necessary.
- Doors should not be stored or fitted in the building until the wet trades such as plastering, painting etc. have been completed and the room is dried out.

Finishing prior to Installation

- See *Pre-finishing the wooden parts* - Very important: We do not recommend wax or oil finishing systems.

Trimming

- This internal folding sliding door set is not designed to be trimmed on site and should be fitted as supplied.

Conditions of Sale

- We shall not be held responsible for any incidental work expenses arising out of or because of any defect in our product, or bad workmanship to our product. In the event of the goods having manufacturing defects and requiring replacement, our liability will be limited to the value of the door or frame component only. These notes do not affect your statutory rights with the retailer of this product.

Maintenance

Hardware in buildings is subject to deterioration from everyday use, and also environmental attack due to atmospheric and other conditions. We require the following minimum maintenance to be followed otherwise the warranty shall be void.

Track and Bearings:

Using a spatula or similar (not your fingers), apply a small amount (typically a 1/2 teaspoon of white petroleum jelly (Vaseline) or similar lubricant to the inner lip of each side of the track. Ensure that the wheels pass through the lubricant and it is distributed evenly along the track. Put additional lubricant around bearings. Lubricant reduces wear, improves smoothness and further protects against corrosion or track and bearings. Remove all surface contaminants by wiping all visible track surfaces with a damp soft cloth and mild detergent, then wipe clean with a clean cloth. In severe environments, apply a thin film of corrosion preventative such as WD40, by wiping with a soft cloth moistened with one of these products.

Stainless steel bearings are manufactured from hardening-grade stainless steel and although this material performs considerably better than plated steels, it is susceptible to corrosion unless maintained as described above.

Hangers, Pivots and Brackets:

A light spray application of a corrosion preventative such as WD40, followed by a light wipe with a dry cloth to remove excess, is recommended to all hangers, pivots and brackets. Exposed surfaces should first be wiped with warm soapy water and a soft rag, and then rinsed clean before applying preventative.

Hinges:

Wipe down the visible surfaces with warm soapy water on a soft rag and then rinse off by wiping with a clean damp rag. Application of a thin film of light machine oil or WD40 will help to maintain the original lustre of the metal finish. Be careful not to get these compounds on the timberwork itself as may cause staining.

Drop bolts:

Spray application of a suitable lubricant such as WD40 to the sliding pin inside the bolt and to the lock cylinder is recommended. A tube attached to the nozzle will help to concentrate the spray where you want it to go. There are access holes or slots on all drop bolt products so that this can be done without removing the locks from the doors.

Frequency:

The procedures mentioned above need to be carried out as often as is necessary to prevent deterioration in the installed environment, however we recommend the following minimum frequency of application:

General environment - 6 monthly

Please be careful not to get the lubricants or other liquids above on the Timber components as may cause staining of the timber.

The properties of timber

No two trees produce identical grains or colour of wood and this adds to the beauty of a natural product. We therefore cannot guarantee that all doors and frame components will look exactly the same in grain and colour. Warping of wood is not a defect if it does not exceed 1/4 inch (6mm) in its installed position.

Maintaining the doors and frame

We suggest additional treatment and finishing may be required at least once a year or sooner if there is any indication of deterioration in the wood protective finish used.

Contents (1)

IMPORTANT: Please check the contents of the packages to ensure that all parts are present and in good condition before booking your installation

Timber parts

Door 1 - Pivot hinge door - quantity 1

40-1L-06S-1	40-4L-06S-1	40PFW-1L-06S-1	40-1L-06SG-1
40-1L-07S-1	40-4L-07S-1	40PFW-1L-07S-1	40-1L-07SG-1
40-1L-08S-1	40-4L-08S-1	40PFW-1L-08S-1	40-1L-08SG-1

Door 2 - Middle door - quantity 1

40-1L-06S-2	40-4L-06S-2	40PFW-1L-06S-2	40-1L-06SG-2
40-1L-07S-2	40-4L-07S-2	40PFW-1L-07S-2	40-1L-07SG-2
40-1L-08S-2	40-4L-08S-2	40PFW-1L-08S-2	40-1L-08SG-2

Door 3 - Access door - quantity 1

40-1L-06S-3	40-4L-06S-3	40PFW-1L-06S-3	40-1L-06SG-3
40-1L-07S-3	40-4L-07S-3	40PFW-1L-07S-3	40-1L-07SG-3
40-1L-08S-3	40-4L-08S-3	40PFW-1L-08S-3	40-1L-08SG-3



Door Size

- 1.8m (1790mm) wide Set - Door Size: 40mm x 572mm x 1981mm
- 2.1m (2090mm) wide Set - Door Size: 40mm x 672mm x 1981mm
- 2.4m (2390mm) wide Set - Door Size: 40mm x 772mm x 1981mm

Frame pack comprises of 1 x Top frame section (head) & 2 x Side frame section (jamb)

40-06SCL-4	40PFW-06SCL-4
40-07SCL-4	40PFW-07SCL-4
40-08SCL-4	40PFW-08SCL-4

Seals

	Bubble seal R9885	2 metres x 4
	AQ21 Draft seal AQ21B2.3	2.3 metres x 4

Hardware

E22MWDNS3LRSTS

Top pivot - quantity 1

Top pivot fixing pack - quantity 1 pack

Bottom Wall Pivot - quantity 1

Bottom Wall Pivot fixing pack - quantity 1 pack

Half offset hinges - quantity 3

Half offset hinges

fixing pack - quantity 1 pack

Intermediate carrier - quantity 1

Intermediate

fixing pack - quantity 1 pack

Straight Hinge - Quantity 2

Straight Hinge

fixing pack - quantity 1 pack

DBMI100NRX

Minuet drop bolt non keyed - quantity 2

Non-keyed drop bolt

fixing pack - quantity 2 packs

Includes drop bolt striker plates

DBMISPS

Blank plate and driver pack - quantity 2

Blank plate

fixing pack - quantity 2 packs

Optional extras

Magnetic catches EWMP

Plastic magnetic door holders

- quantity 1 set

Metal door holder DDDS035

- quantity 1 set



Contents (2)

DELSWSS

3/4 Pozi wood screw - quantity 7



5962-66-85

Latch Striker Plate - quantity 1



INTPLS

Blank Latch Plate - quantity 1 pack



185-55RFBODY-B

Tubular Mortice Latch - quantity 1

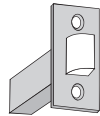

HSSDB3MM

3mm Dia Drill - quantity 1

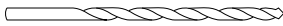

FWB16MM

12mm Dia Wood Drill - quantity 1



CLESSP

Jamb Drilling Template - quantity 1



DDAK001

8mm Allen Key - Quantity 1



K1570911(53)

Installation bag - quantity 1

Hardened steel wood screws
pozi flat countersunk yellow



A) M4 x 60mm - quantity 12

B) M6 x 80mm - quantity 14

C) Hardened steel frame fixings - quantity 22



D) HDS long drill bit 6.5mm x 148mm - quantity 1

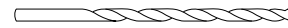

E) SDS drill bit 6.5mm x 160mm - quantity 1

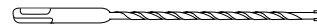

F) 1/4 Hex T30 insert bit - quantity 1



G) Cover caps

Brown - quantity 10

White - quantity 10



I) 3/4 inch pozi wood screws- Qty 7

Pre-finishing the wooden parts- Unfinished oak sets only

After you have checked the parts list to ensure you have all the parts ready and all components are in good condition (replacement parts are available) please carry out the pre-finishing procedure specified.

Please do not proceed with installation or assembly before applying a high quality decorative wood coating like clear internal varnish or woodstain or paint to all the wooden parts as recommended below. It will be difficult for you to apply the wood coating correctly once the product is assembled and installed. Failure to totally finish the doors and frames will expose them to the ambient room conditions and will invalidate the guarantee.

- Apply at least 3 coats of the decorative protective wood coating to all faces, edges and the top and bottom of each door and the oak door frames, following the wood finish or paint company's recommendations.
- To enhance the 'Natural Oak' appearance use a clear or natural internal varnish or pu coating. If you require a different wood finish choose a wood stain with a varnish in it or, if using stain only, you need to apply 2 top coats of clear varnish on top of the stain to adequately protect the doors and frames.

- If any scratches occur during installation please apply another coating.
- We do not recommend wax or oil finishing systems.

Very Important: Do not use steel wool or allow steel or iron fragments to come into contact with the untreated oak timber as this will cause oxidation resulting in black stains.

Deciding the brickwork or stud wall opening size and preparing the site

<u>Assembled Frame Size</u>		<u>Brick / Stud wall opening</u>	
1.8m	1790mm Wide x 2054mm High	1.8m	1800mm Wide x 2064mm High
2.1m	2090mm Wide x 2054mm High	2.1m	2100mm Wide x 2064mm High
2.4m	2390mm Wide x 2054mm High	2.4m	2400mm Wide x 2064mm High

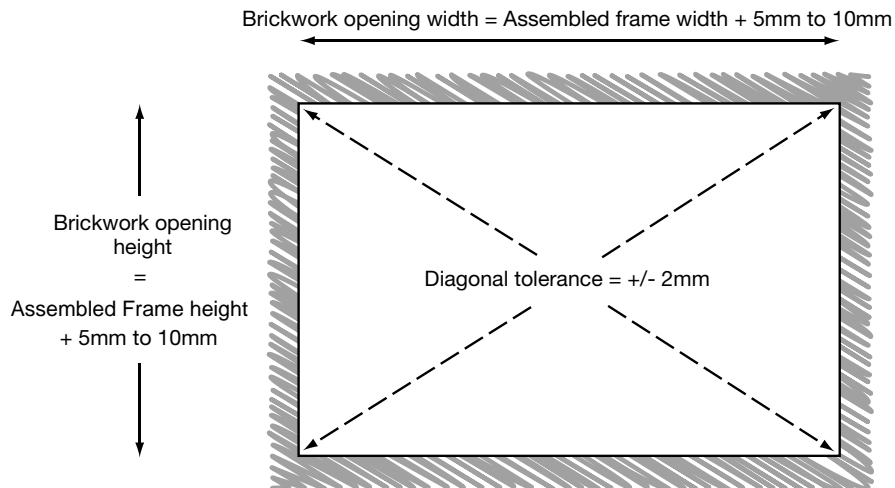

- 1 Identify the left and right jambs and frame head.
Lay a protective covering on the floor and lay out the frame on the floor with the head, left jamb and right jamb in position.
Ensure the thinner 28mm edge of the frame jamb is upright pointing towards you and the 43mm wider edge is on the floor.

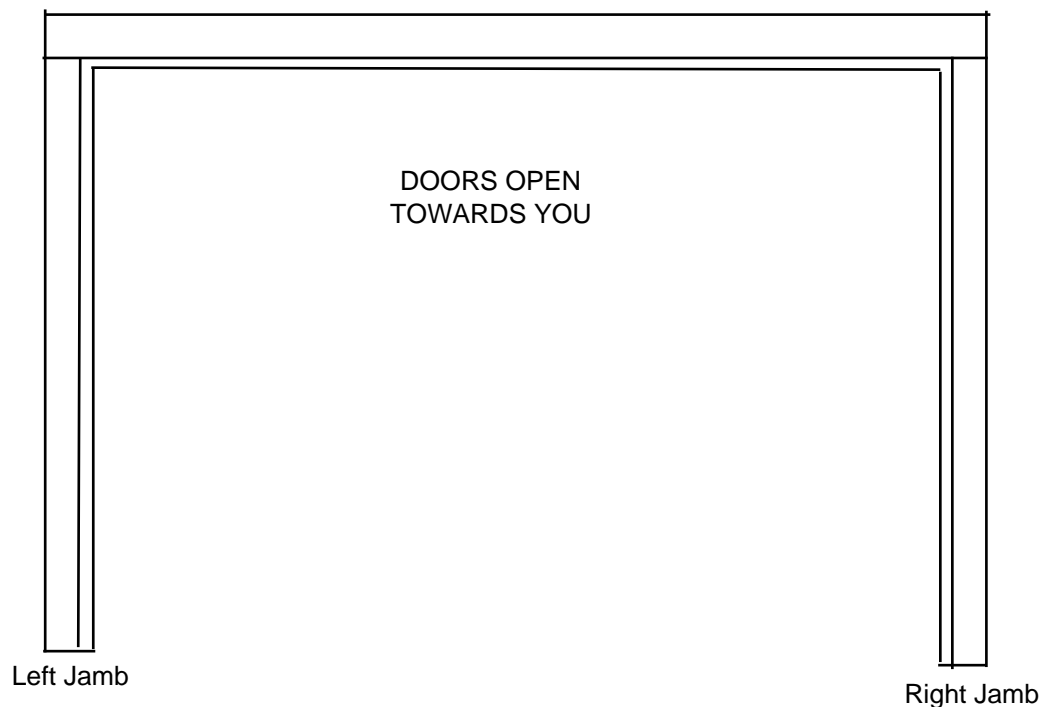

NOTE: For **A** Right opening the Pivot jamb is the Right jamb.
For **B** Left opening the Pivot jamb is the Left jamb.
(See point 4)

2a Select the pivot frame jamb (Depends on which opening direction you choose. See 1 and 4)
 Also locate the METAL TEMPLATE in the hardware pack.
 Place the template TIGHT against the rebate and up to the Door Stop and level with the bottom of the frame jamb.
 Mark the 3 holes in the template onto the frame jamb.

Note:
 The Template is slightly wider than the frame.

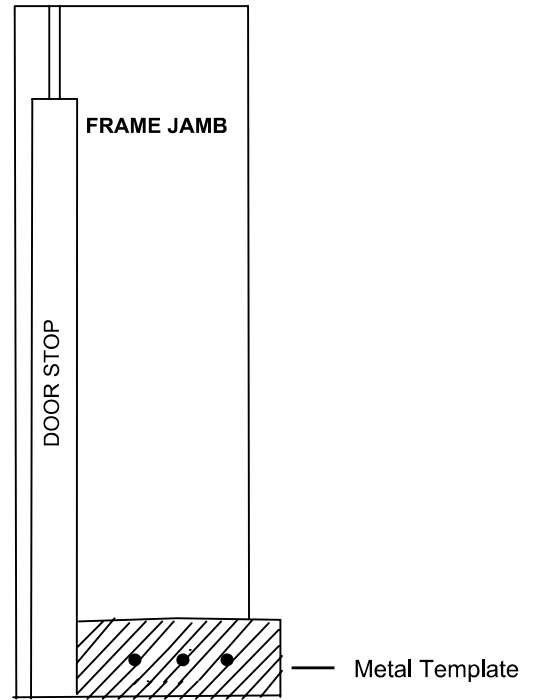

2b When you have marked the location of the 3 holes, using the template.
 Use a 3.0mm Dia drill to drill pilot holes for all three holes.
 Then use the 12mm flat wood bit for the centre hole only.
 These are for the location of the wall pivot.

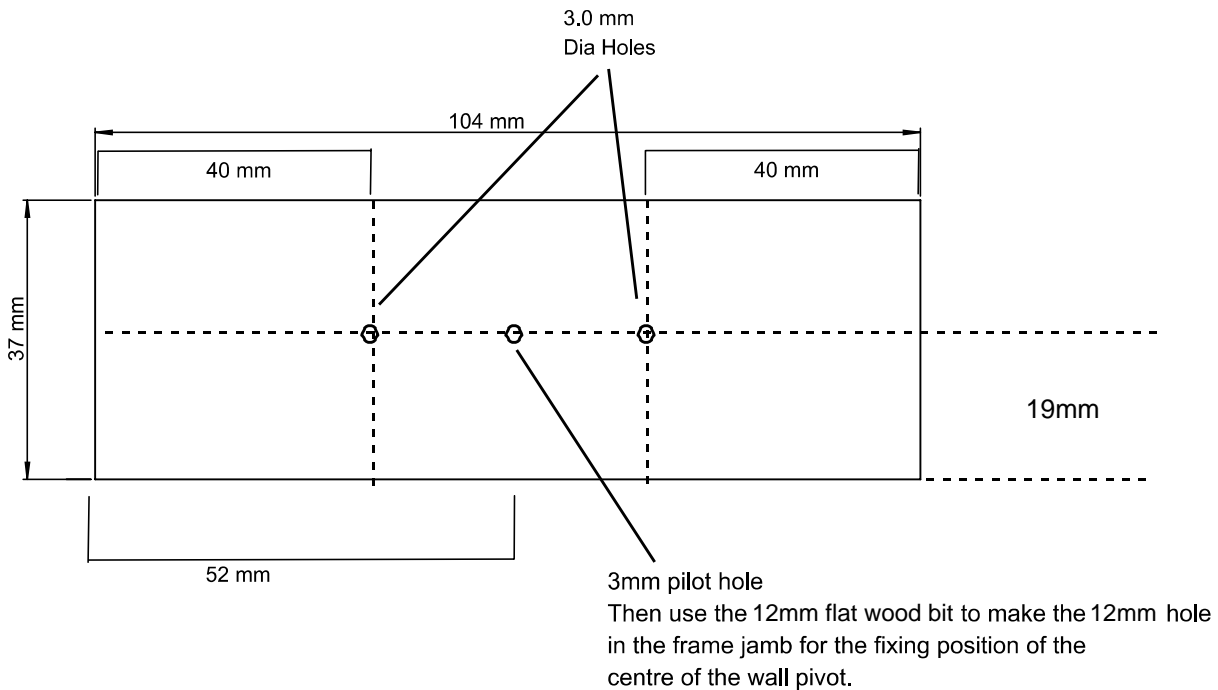

Preparing and Assembling the frame

3 Assemble the jambs to the frame head with the M4 x 60mm Pozi (A) screws provided through the pre-drilled holes.

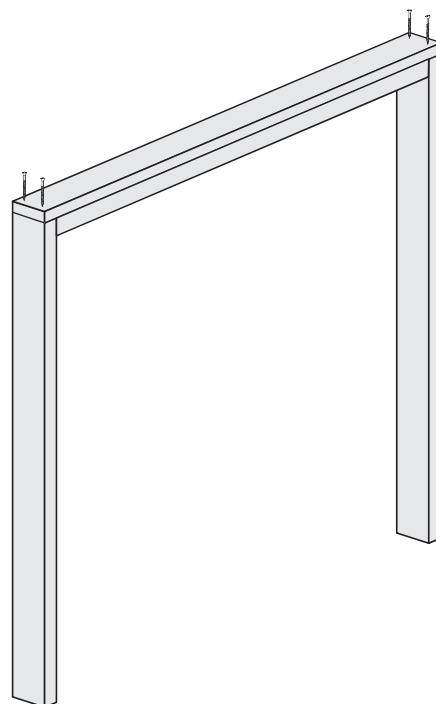
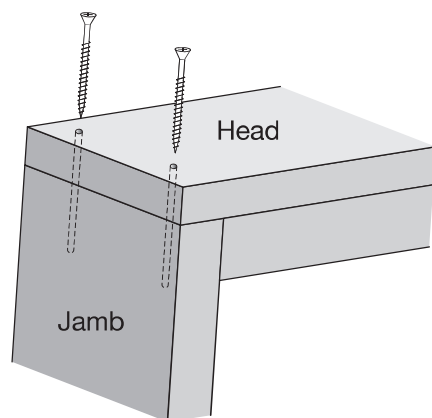

Very Important.
Carefully check frame is tightly fixed together at the Head/Jambs

Opening options

4 Choose the opening direction before installing the frame. The internal door set is reversible, with left or right opening options. Before fixing the frame into the opening or fitting the doors, choose the direction you wish the doors to open. This will determine which instructions, **A** or **B**, to follow and which door to fit first.

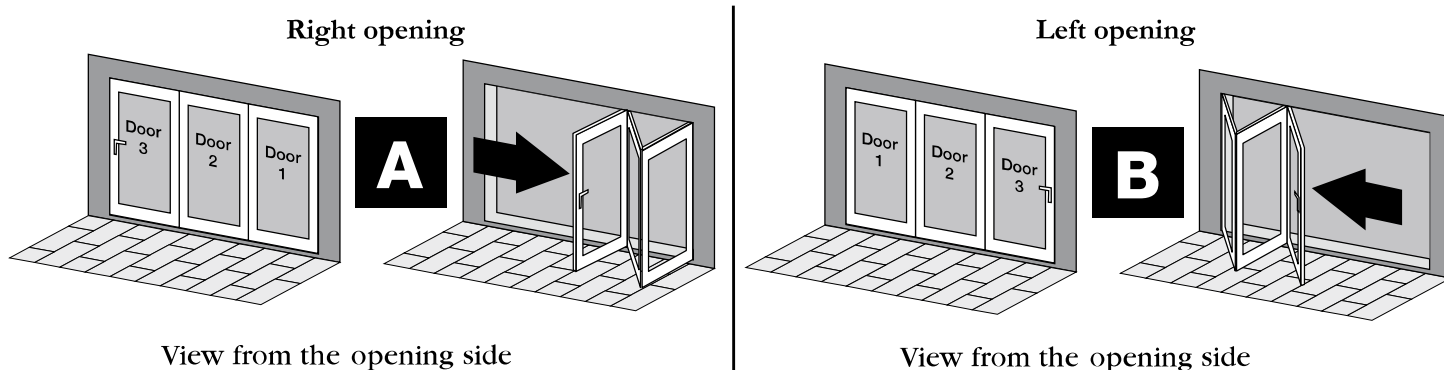

Follow the appropriate instructions for your choice of opening.
Follow **A** for Right opening. Follow **B** for Left opening.

5 Fit the AQ21 draft seal (2.3m) into the frame jambs

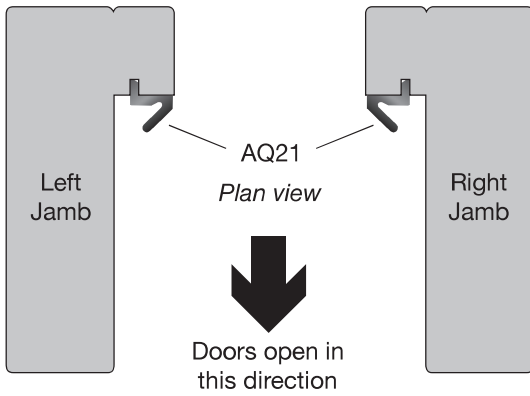

Please note well -

The frame should be installed into the opening with the thinner frame ends facing the same direction as you want the doors to open.

6 Fit the AQ21 draft seal into the frame head

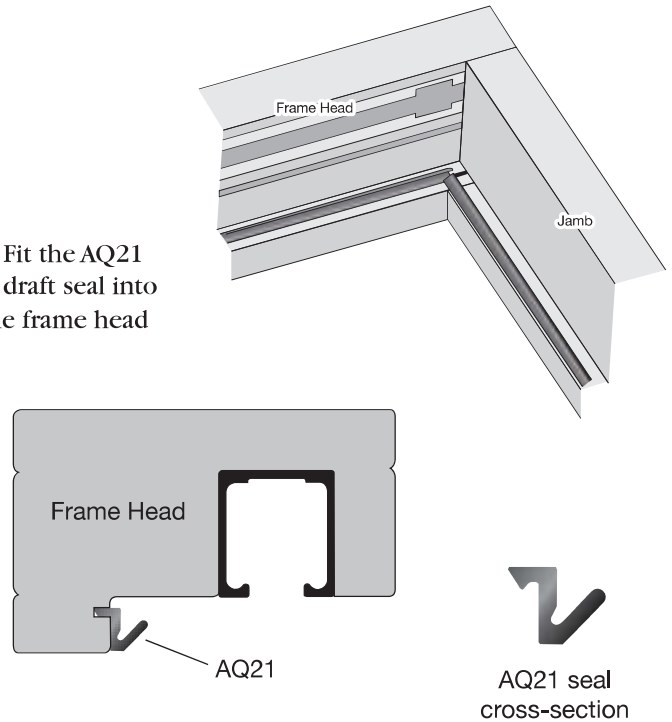

Installing the assembled frame

Proceed to install the assembled frame. **It is critical that the frame is fitted square and level** with tolerances as follows. Ensure the frame is installed straight and square, if necessary use shims (packers) between the frame and the brick opening.

The height (H) must be the same across the whole width of the opening, +/- 2mm.

The diagonals must be the same, +/- 2mm.

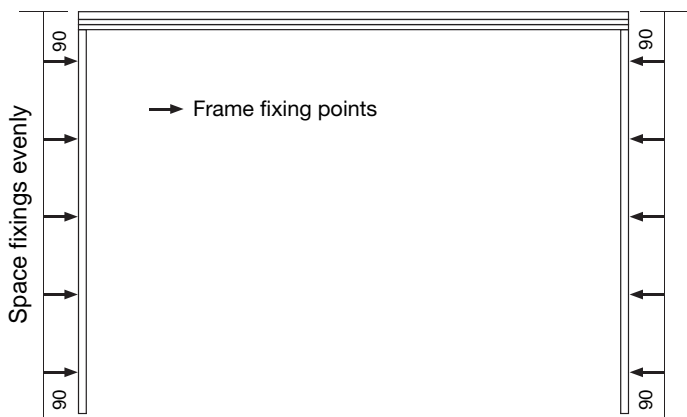
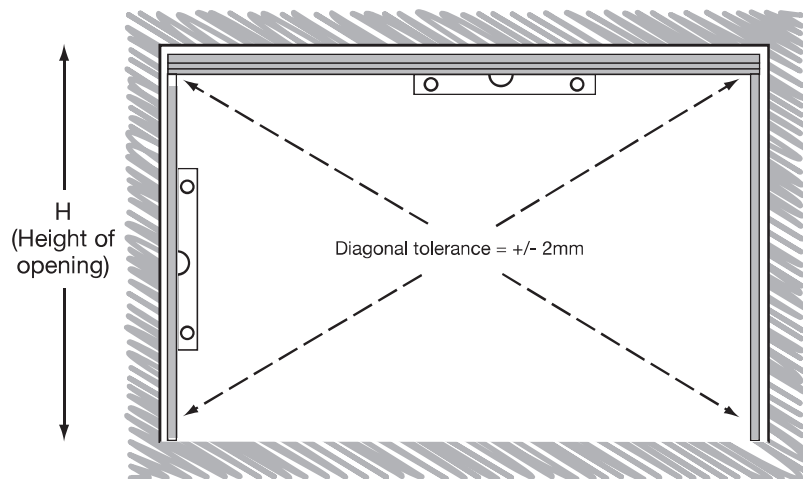

7 Secure both Jambs into the brick work/stud wall opening with 5 fixings - evenly spaced - using the **direct frame fixings (C)** provided for brick work and screws (B) for a stud wall.

IMPORTANT TIP.

Drill the frame jamb fixings behind where the doors are, so the holes can only be seen when the doors are open.

For brick work

Use the **direct frame fixings (C)** as follows:

- 1) Use the 6.5mm x 148mm (D) HSS drill (supplied) to drill holes in frame jambs, aluminium track and steel.
- 2) Use the 6.5mm x 160mm (E) SDS masonry drill (supplied) to drill into brickwork.
- 3) Use the Torx T30 bit (F) (supplied) to screw in the **direct frame fixings (C)**.
- 4) Cover the screw heads using the white or oak cover caps (G)

Assembling the top track

A Instructions for Right opening

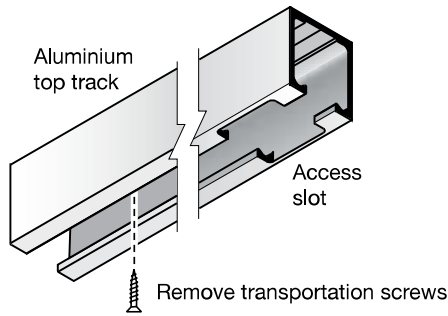

8a Remove the two transportation screws to release the aluminium top track from the frame head.

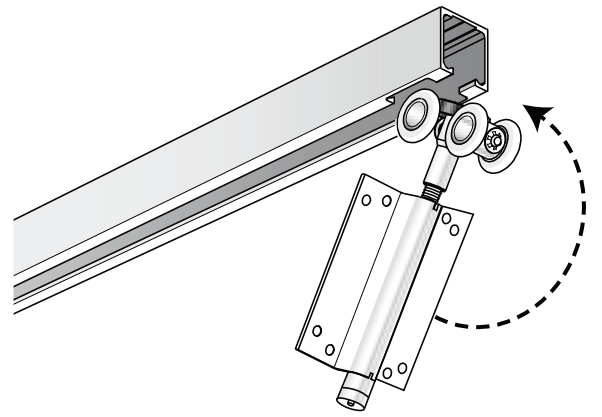

9a Slide the intermediate carrier wheels into the track.

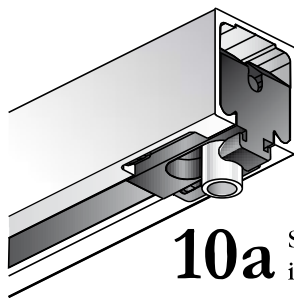

10a Slide plastic top pivot into the track

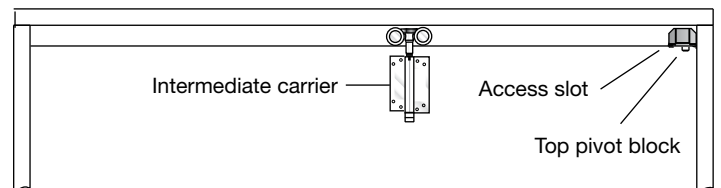

11a Re-secure the top track to the frame head using the two transportation screws **only** at this stage.
Important - The track access slot is on the right when viewed from the opening side.

Assembling the top track

B Instructions for Left opening

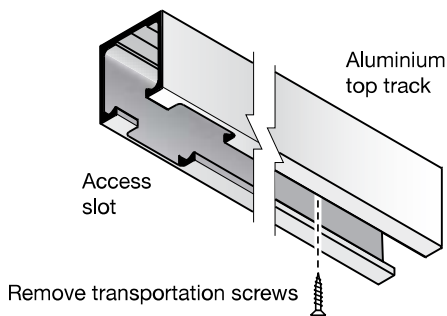

8b Remove the two transportation screws to release the aluminium top track from the frame head.

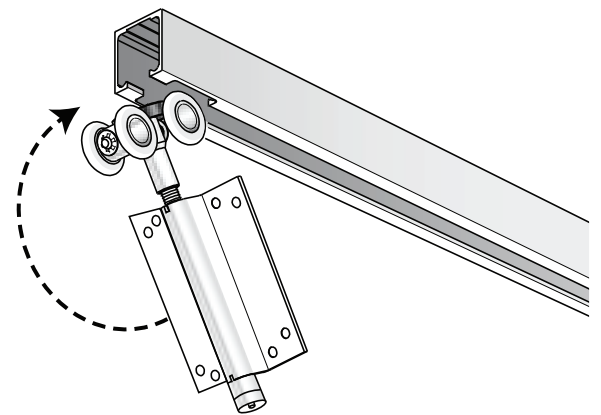

9b Slide the intermediate carrier wheels into the track.

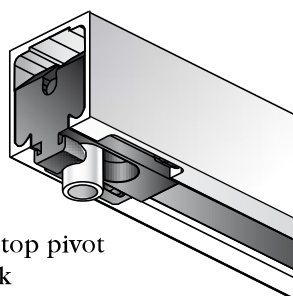

10b Slide plastic top pivot into the track

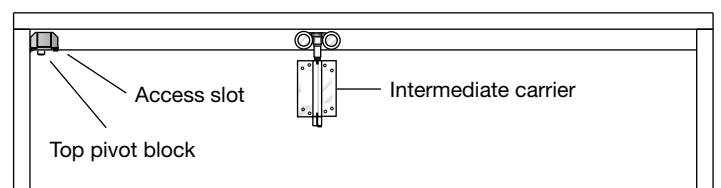

11b Re-secure the top track to the frame head using the two transportation screws **only** at this stage.
Important - The track access slot is on the left

Assembling the top track and top and bottom pivots (continued)

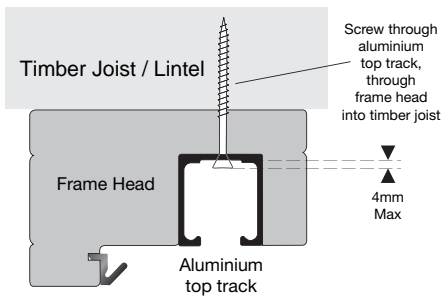

12 The aluminium top track, which is temporarily held in place with transit screws, has been pre-drilled for fixing points into the lintel or timber joist.

The aluminium track must be securely fixed, through the head of the frame, into the timber joist using the woodscrews provided (B) or lintel using the frame fixings (C).

1) Locate the pre-drilled holes in the aluminium top track

For fixing to a lintel

2) Use the 6.5mm x 148mm (D) HSS drill (supplied) to drill through pre-drilled holes, through timber frame head and into the lintel, use the frame fixings (C) to screw through the aluminium top track, frame head and into the lintel.

For fixing to a timber joist

3) Use the M4 x 80mm (B) screws provided to screw through the aluminium top track and frame head into the timber joist.

13a Assemble top pivot block. Slide and click cover plate onto the pivot block. Screw through cover plate into rear of access slot.

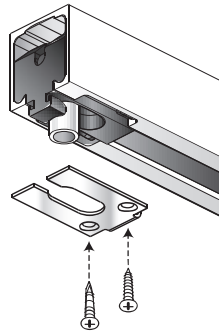

13b Fix the bottom pivot pin only (not the hinge) into the frame jamb, securing with screws provided, into the holes you drilled in Step 2.



Overview of door and hardware arrangement

Choice **A** for Right opening

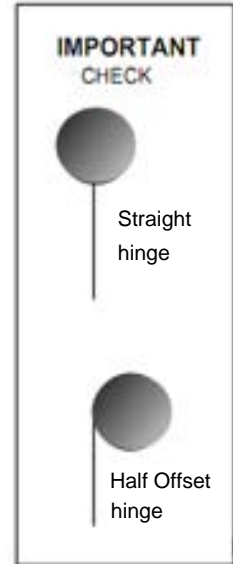
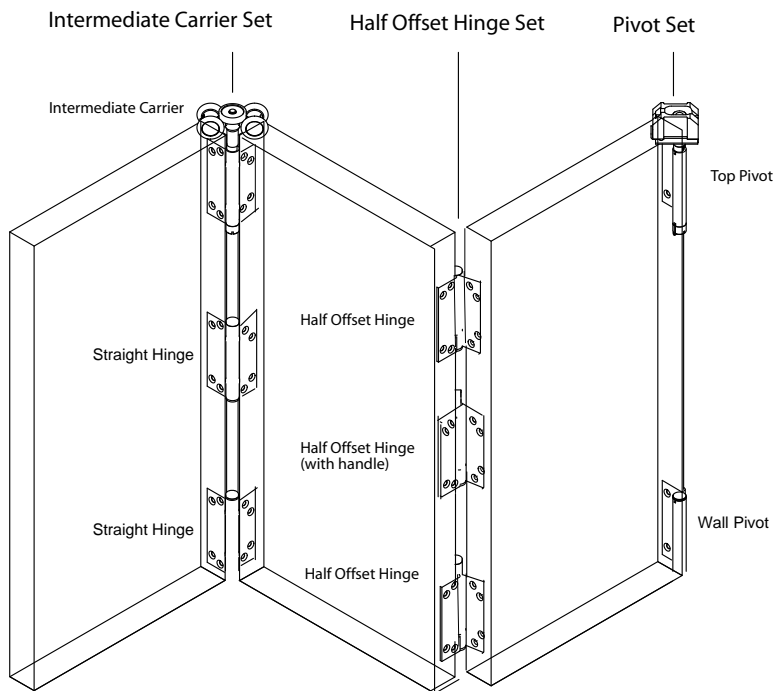

Choice **B** for Left opening

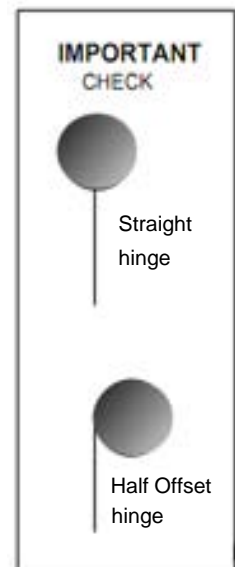
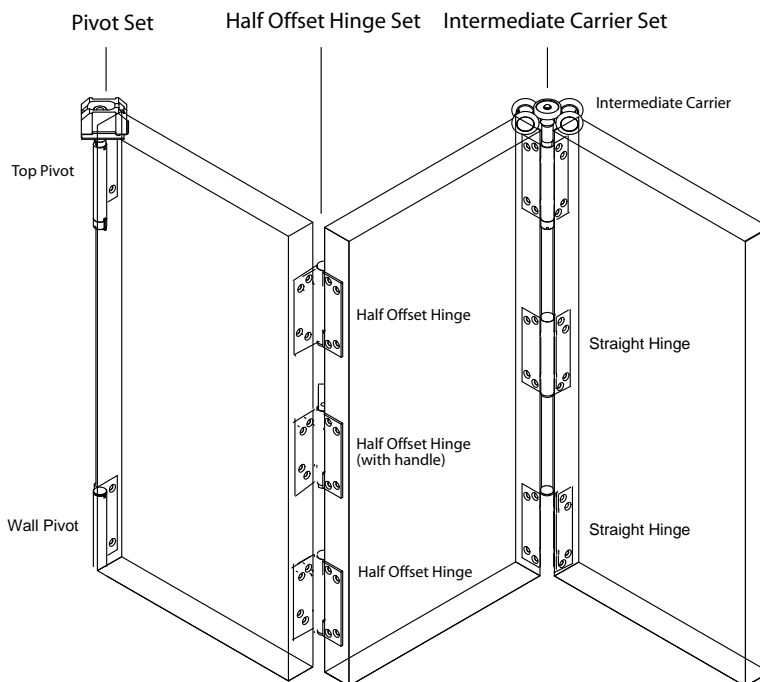

Fitting the dropbolts

14 Fit the Minuet drop bolt to the bottom of door 1 using the pre-cut position.

Fit the Minuet drop bolt to the top of door 1 using the pre-cut position.

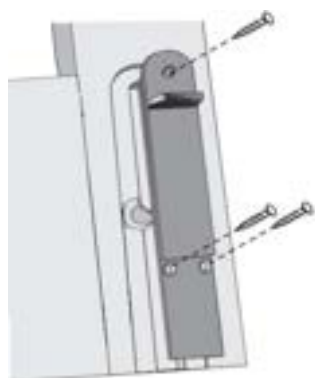

15 Fit the drop bolt striker plate to the frame head in the pre-cut position.

Use the blank plates to cover the unused pre-cut positions.



Special Note

To use the bottom drop bolt it will be necessary to make a locating hole in the floor, to be covered by the striker plate. Using the bottom drop bolt provides greater rigidity when the doors are closed and this is our recommended installation method.

If however it is preferred the bottom striker plate and hole are NOT drilled and fixed into the floor, leaving the bottom minuet drop bolt unused.

This installation will leave the floor completely clear, but the doors are less rigid when closed and during operation.

Fitting the pivot door (door 1)

Before fitting door 1 thoroughly clean the top and bottom tracks

16 The top pivot default is for left opening. For right opening, carefully remove centre bolt from hinge barrel then re-insert from the other end.

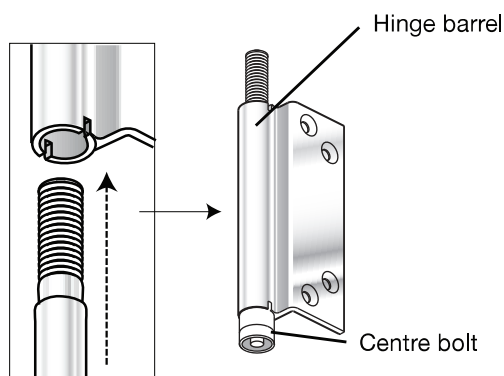

17 Fix the top pivot hinges to door 1. Fix the pivot hinges 15mm from the top of the door to the outer edge of the hinge plate. Drill pilot holes and use the screws provided to secure the pivot hinges into the rebate on the edge of the door.

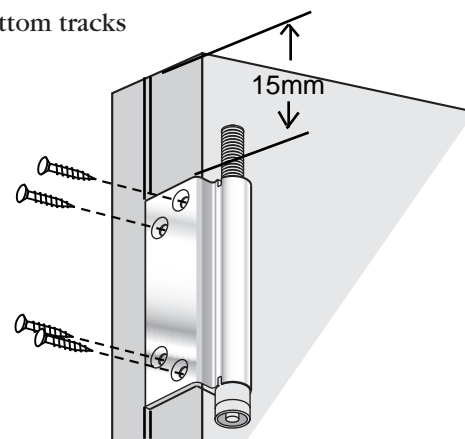

18 Remove the hinge plate from the bottom wall pivot.

Position the hinge plate into the rebate at the bottom edge of Door 1 and slide it up the door until the bottom of the hinge plate is 34mm up from the bottom edge of the door. Carefully mark the hole position of the hinge plate onto the edge of the door. Drill pilot holes using the 3mm Drill provided then fix the hinge plate with the Torx head screws provided.

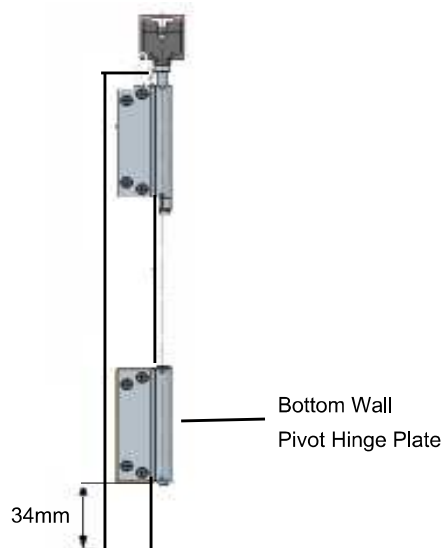

Fitting the pivot door (door 1)

- 19** Lift the pivot door onto the bottom wall pivot. Support the door then screw the top pivot centre bolt into the pivot block until the door swings freely.

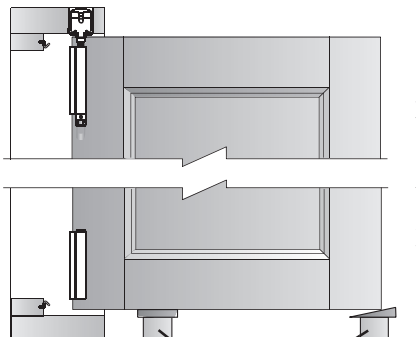

Temporary supports

Note:
Screwing top pivot bolt in and out adjusts height.

- 20** Adjust alignment of pivot door as shown. Leave a 7mm gap between the door edge and the frame jamb.

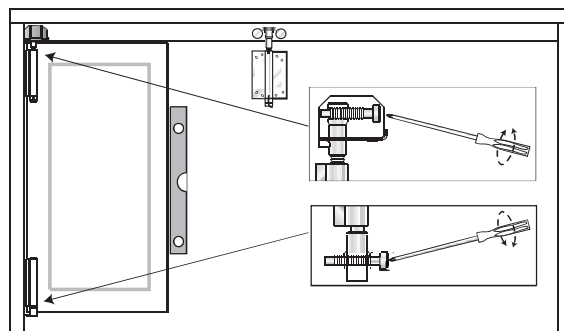

- 21** Fit the half offset hinges to the inside edge of door 1.

Fix through the hinges using the Torx head screws provided in the pre-drilled holes.

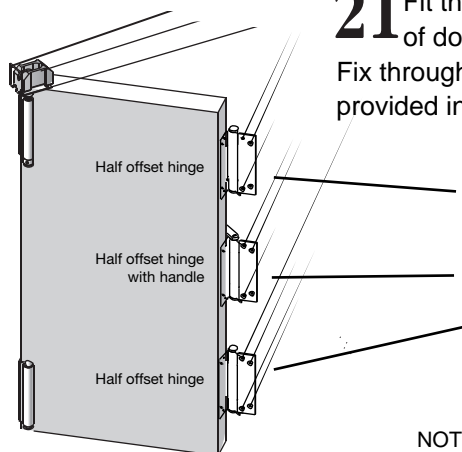

IMPORTANT- Check Half offset hinge are on the correct door.

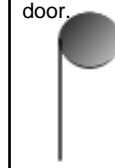

NOTE: Hinge barrels and centre hinge handle to inside.

Fitting the middle door (door 2)

- 22** Lift door 2 and locate the intermediate guide in the bottom channel. Support door on blocks then screw top carrier bolt into top wheel assembly.

Finally fix door 1 and 2 together using the half offset hinges in the machined position, using the Torx head screws provided.
Note: Handle to the inside.

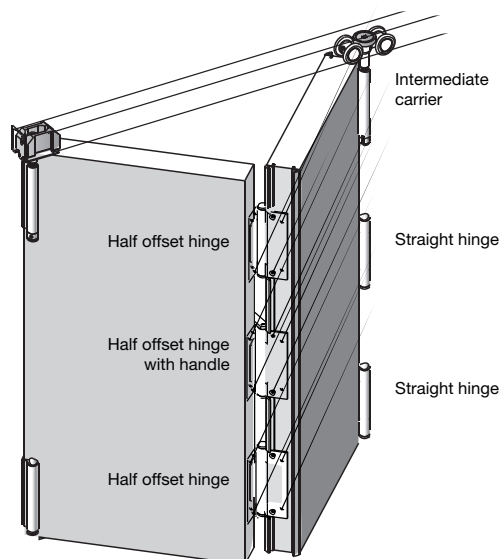

IMPORTANT- Check Straight hinge are on the correct door and location.

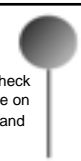

Fitting the access door (door 3)

23 Attach door 3 to the Intermediate Carrier and Straight hinges in the pre machined positions using the Torx head screws provided.

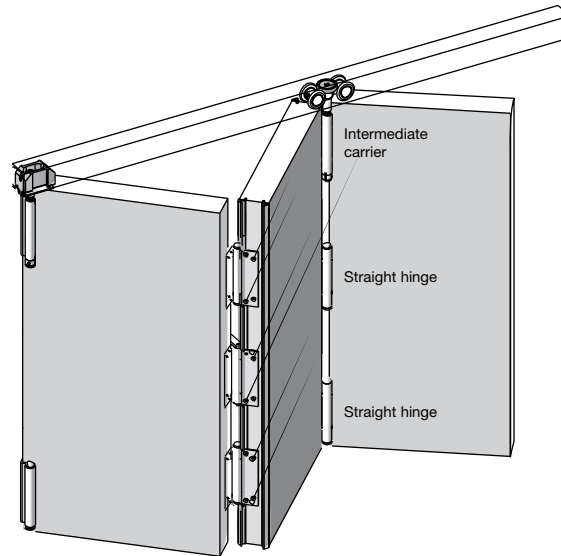

Fitting the draft seals to the doors

24 Fit draft seals to doors as follows:

- 1 strip type AQ21 to pivot door 1
- 4 strips type Bubble seal to door 2

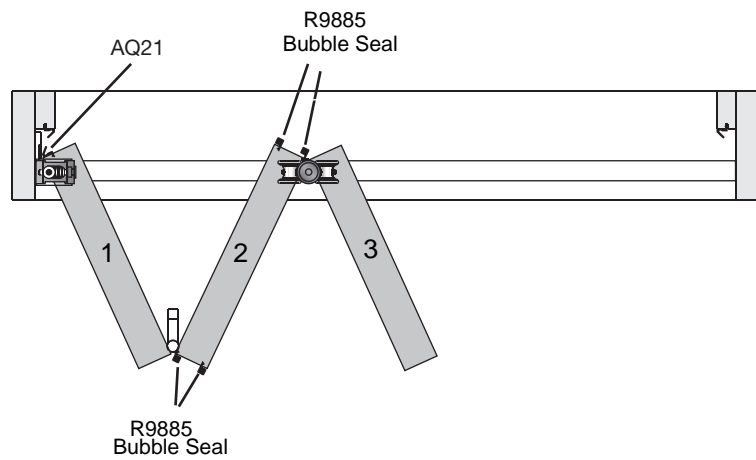

Adjusting the operation of the doors

25 Raise or lower the height of the doors by adjusting the top pivot and intermediate carrier. Insert the Allen Key provided then turn clockwise to raise and anti clockwise to lower the doors.

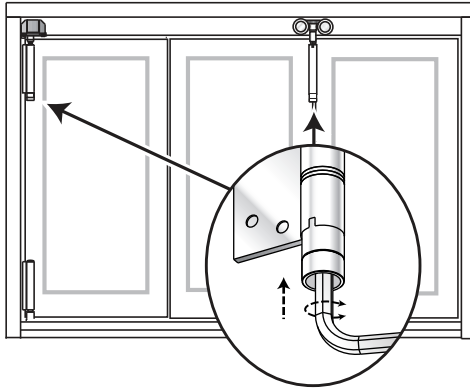

26 Adjust the top and bottom pivots to move the doors left or right.

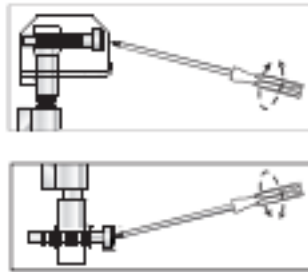

Final adjustment, correct spacing

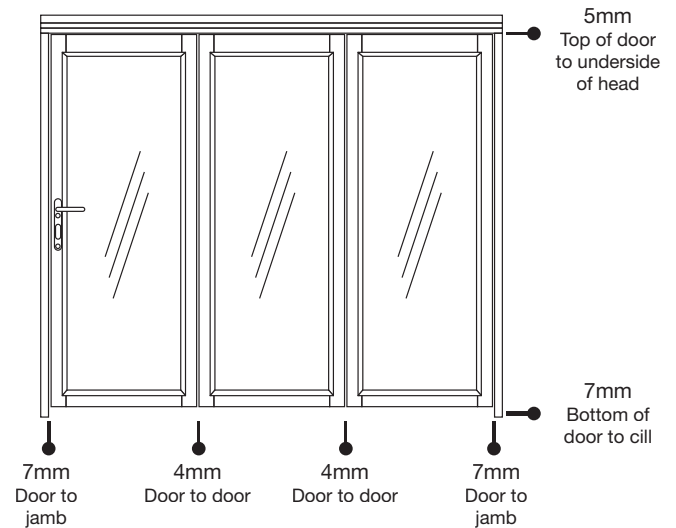

Fitting the mortice latch

27 Fit the Tubular Mortice Latch into the pre-machined position in the access door (3) using the 3/4 Pozi wood screws provided.

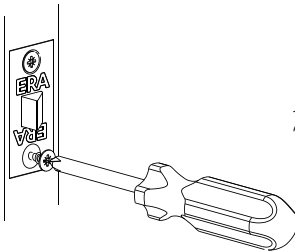

28 Fit the latch striker plate to the frame jamb. Adjacent to the Tubular Mortice Latch using the 3/4 Pozi wood screws provided.

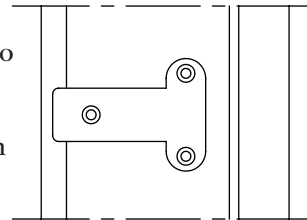

29 Fit the Blank Latch Plate and keep cover to cover the unused machining in the pivot side Frame Jamb using the 3/4 Pozi wood screws provided.

Fitting the catches to the doors

OPTIONAL EXTRAS

30 Fit the Door Stop and magnetic catches in the positions shown using the fixings provided.

