

70

EXTERNAL ALUMINIUM 5 DOOR BiFOLD DOOR SET

Assembly Instructions
Bespoke and Standard Sizes

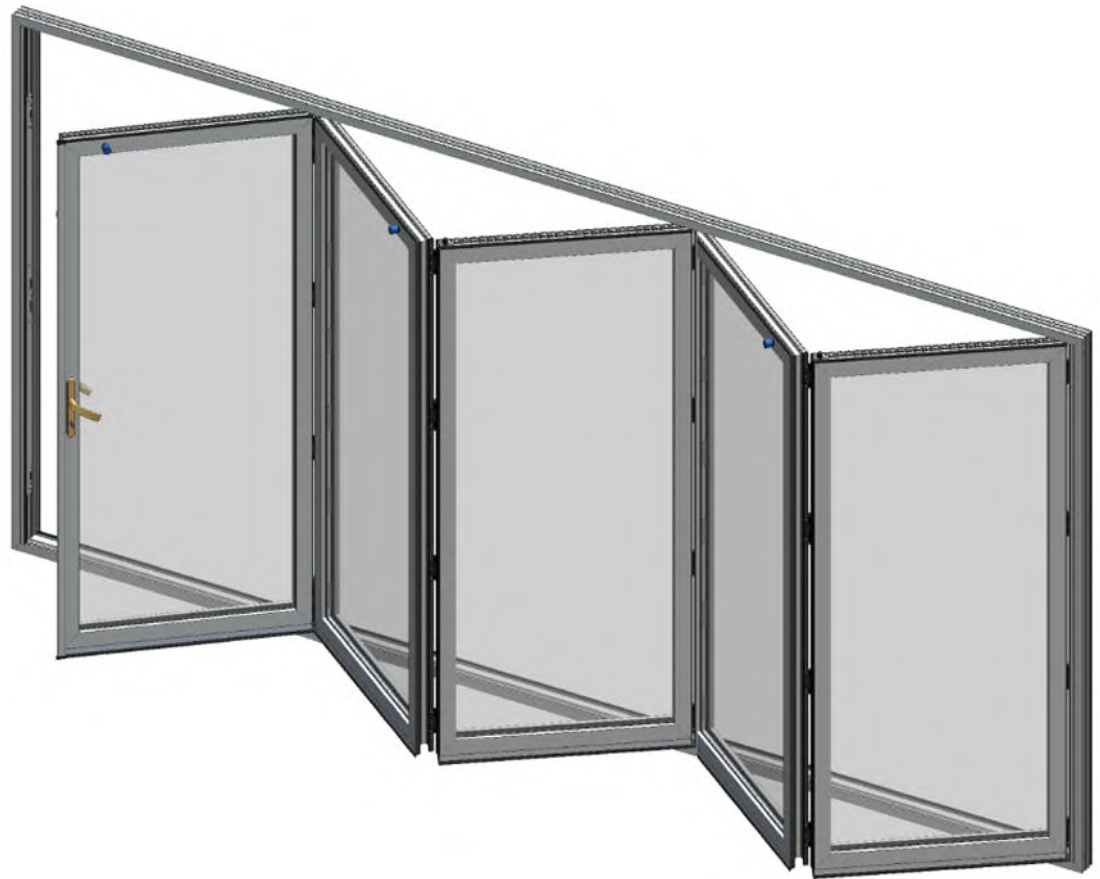

About your patio door set

All products must be installed in accordance with accepted good trade practice (and in accordance with supplied instructions where applicable), and maintained in accordance with these procedures or else the warranty shall be void.

Important Information

All of our external aluminium bifold doors and frames, powder coating finish, glazed units and hardware components are guaranteed for a full 15 years against the occurrence of manufacturing faults, all subject to correct installation, regular maintenance and care in use as detailed below and the previously issued Home Owner Manual.

We recommend that a competent trades person installs this product. A single person must NEVER carry out the installation, as some of the components are heavy.

Bifold door sets are often installed too early into the build project or left in a room where other works are being carried out, meaning they get covered in heavy dust, dirt and building debris. This will cause damage to the tracks and hardware when operated and also affect the surface area finish. It is recommended the door sets are installed as late as possible into the build. If installing into an area where regular works and trades will be present, please ensure the product is fully protected and kept free of heavy dust, dirt and debris.

All items must be checked for any missing components and / or damages, including temporarily removing any protective tape, and then reapplying before installation, and must be reported within 72 hours of delivery and before commencing installation.

We cannot accept any claims for damages, including scratches to the powder coated aluminium or glass. reported 72 hours following delivery, or once installation has commenced. Any claims for damages where heavy building dust, dirt or debris is present will not be accepted.

By installing the door set, you are accepting the product in the condition it has arrived to you in, and that is free from any damages, blemishes or defects that would have been apparent when inspecting the product.

We will not be held liable for any incidental expenses arising either directly or indirectly of any product related issues (s).

Powder Coating Finish and Maintenance

All our standard aluminium bifold door sets are supplied fully powder coated in a satin finish providing a high quality and durable finish, unless otherwise stated.

Our standard range of colours are Anthracite grey RAL 7016, Jet black RAL 9005 and Gloss white. If you have selected an alternative custom colour option and require the colour and RAL code please contact us.

To maintain the external aluminium powder-coated finish, wash regularly with soapy water and then dry off with a soft lint-free cloth. As a minimum, the external surfaces must be washed at least every three months, and monthly if within five miles of the sea or in an industrial area. Our general recommendation would be to wash the external aluminium every time you clean your windows, which should normally be more regularly than the minimum requirement.

The powder coating is not guaranteed unless the doors are installed at least 800 metres away from the sea.

Installation

This door set is designed to be installed by competent trades persons with good knowledge and previous experience of installing bifold doors.

Our aluminium doors are supplied with all the essential items, most hardware factory fitted and everything pre-machined. This design allows for simple on-site assembly by experienced trades persons.

All glass will be supplied pre-fitted and toe and heeled, unless specified. For any unglazed door sets the loose glass will require installing by a competent trades person experienced with installing glazing into doors and windows

About your patio door set (Cont)

The outer frame needs to be securely fixed into the opening perfectly plumb, square and level on all planes. The aluminium sliding doors are bottom hung, the weight of the doors is supported via the sliding hardware and threshold. **Important: The threshold must be sufficiently packed to ensure there are no dips or rises along the full length of the bottom tracks. When fixing the frame head, ensure there is no bowing.**

All our external bifold door sets have been pre-assembled in our factory. They are installed into a steel framed testing rig where they are fully operated, including checking the doors lock, and open and close smoothly.

Glazing Units

Loose glass should never be placed directly onto hard floors such as concrete, but should be placed on cardboard, sheeting or wooden batons, on edge rather than flat. The glass should be stored on its edge and at a 3 – 6 degree angle. Glass should not be stored horizontally or on top of each other and should not come into contact with anything harder than itself.

To reduce carbon emissions from the home and to keep heating and cooling bills down, the government has recommended that all manufacturers use a special Low E thermal glass within the sealed units to comply with Building Regulations Part L.

This glass is coated with a special substance to comply with the above and occasionally, and in certain light conditions, may produce transient visual effects, this can sometimes look like a transparent film or haze, and make the glass appear cloudy. This is very infrequent and only affects a minority of door sets. As a company, we do have to comply with the new regulations which are for the benefit of all, and this is not a defect.

Due to demands for better thermal efficiency, it is normal for condensation to form on the outside of the glazing units, to the exterior side of the property. This demonstrates that the glass is performing as it should by reducing the transfer of heat from the internal side of the property to the external side of the property, this is not a defect. For any condensation forming to the inside of the property, this is normally due to high levels of moisture in the air and / or insufficient ventilation in the room, the moisture is then forming on the cold surface. If condensation is forming inside the glazing unit (between the panes of glass) it is likely that the glazing seal has been compromised

Tempered glass means it has been toughened to be up to five times stronger than normal glass. It is unusual to break such strong glass, but sharp objects hitting the glass at certain points can cause breakage. Tempered glass is also known as safety glass. This means that if it breaks it will shatter into smaller fragments which are less likely to cause injury, unlike non-tempered glass which breaks into large, sharp fragments.

Laminated glass is also called safety glass and comprises of multiple layers of glass sandwiched together. Due to its high strength, this prevents the glass from breaking into large pieces. If the glass breaks, it will produce a 'spider web' effect similar to what is commonly seen in shattered car windscreens. Laminated glass will also increase the sound rating insulation.

Glass must be regularly maintained and cleaned to stop break down of the glass or seals. This can be done using a mild solution such as washing-up liquid diluted in water. Do not use abrasive cleaning solutions as this may cause scratching.

Visual distortions caused by reflections in toughened glazing units are a natural phenomenon and not a fault.

Laminated, toughened or coated glass is acceptable if bubbles or blisters, fine scratches no more than 2.5cm long and / or minute particles are neither obtrusive or bunched. The glass used in sealed units is processed glass, therefore certain blemishes are unavoidable. More blemishes may be visible in laminated glass due to its layered construction.

For carrying out glass inspections, stand at least 3 metres away from the glazing, view at a 90 degree angle and look directly through the sealed unit(s). The glass must be viewed in natural daylight but not with the sun directly on it. Any moisture must be removed from the surface of the glass before inspecting.

About your patio door set (Cont)

Hardware Components

The exterior hardware in your bifold door set can deteriorate from everyday use, and also because of the weather and local environment. That's why regular maintenance of your door hardware is even more important if you live in severe environments like coastal / marine areas and some industrial locations.

We require that the below minimum maintenance is carried out as often as necessary to prevent deterioration. As a guideline, we recommend that this maintenance is done every three months if you live in a marine environment, or every six months if you live in a more general location, otherwise your guarantee will not be valid.

Tracks and bearings

Important: Once your installation has been completed, and before fully operating your door set, please carefully remove any debris / swarf from the top and bottom tracks to ensure nothing comes into contact with any moving components.

After cleaning the tracks, using a microfibre cloth, apply a small amount of lubricant such as a silicone spray to the inner lip of each side of the track. Extra lubricant can be added around the bearings. Adding lubricant in this way reduces wear, improves smoothness and gives additional protection against corrosion of track and bearings.

Hinges, pivots and brackets

A light spray application of a suitable lubricant such as WD40, followed by a light wipe with a dry cloth to remove excess, is recommended to all hinges, pivots and brackets. Exposed surfaces should first be wiped with warm soapy water and a soft rag, and then rinsed clean before applying preventative.

Twin point locks

Spray application of a suitable lubricant such as WD40 silicone spray. A tube attached to the nozzle will help concentrate the spray where you want it to go. There are access holes or slots on all twin point locks, so that this can be done without removing the locks from the doors.

Frequency

The procedures mentioned above need to be carried out as often as is necessary to prevent deterioration in the installed environment, however we recommend the following minimum frequency of application;

General environment – 6 months

Close to marine environment - 3 months

Introduction to Assembly

QUICK GUIDE

Your aluminium bifold door set is supplied with the frame unassembled and in 4 pieces ready for assembly on site.

The doors are all pre-glazed and the glazing is 'toe and healed' in the factory to balance the glazing in each door, then in the full set.

Every bifold door set is pre-assembled in our factory to ensure it is operating perfectly before we deliver it. We then dismantle the frame and remove some hardware, before carefully packing it for transportation to your home.

When you receive the bifold door set to install it, assemble the frame then install it into the brickwork opening.

Attach the hardware to the doors into the frame.

Because the bifold door set has already been assembled and operated in our factory, as long as the frame is installed securely into the brickwork opening, completely level and square in every plane, and the hardware is correctly attached, then the installed bifold door set should operate perfectly, without the need for further adjustment.

**Full and detailed installation instructions are contained
within this Instruction booklet**

Contents

Please check the contents of the packages to ensure all parts are present before beginning assembly

Aluminium Parts

Doors

Door 1 (Door to frame jamb)	Quantity 1
Door 2	Quantity 1
Door 3	Quantity 1
Door 4	Quantity 1
Door 5 (Access Door)	Quantity 1

Order specific frame components *

Threshold	Quantity 1
Drip Cill	Quantity 1
Trickle vent add-on	Quantity 1

Frame Pack

Frame Head	Quantity 1
Frame Jamb	Quantity 2 (1x Left and 1x Right)
Integrated Threshold / Cill	Quantity 1

Integrated threshold / cill (standard open out door sets)

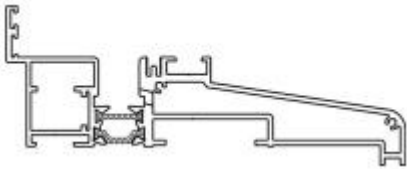

* Drip cill (open in door sets and loose threshold option)

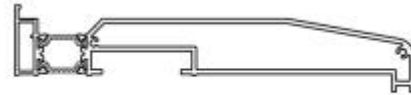

* Threshold (open in door sets and loose cill option)

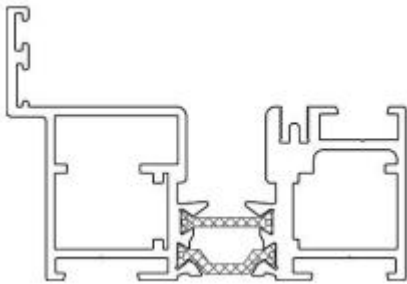

* Trickle vent add on (for trickle vents)

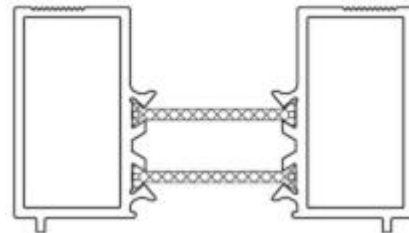

Hardware

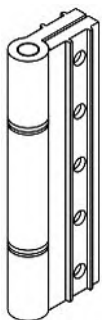

Hinge
Qty 14

Top Guide
Qty 2

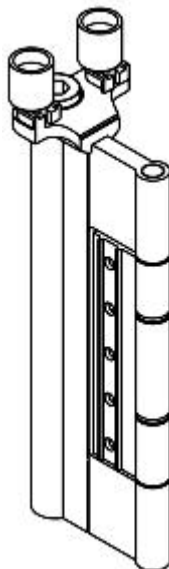

Bottom Roller
Qty 2

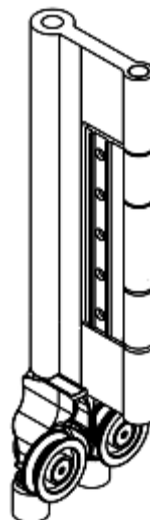

Handles
Qty 1 Pair



Handle Fixing
Bolts Qty 2

Hinge with
Handle
Qty 2

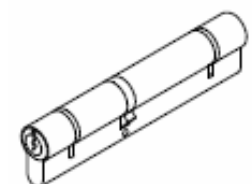
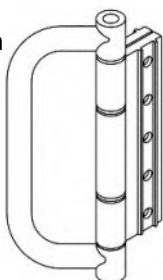

Anti Bump Cylinder
Qty 1 (Keys Qty 3)

Contents (2)

Cill End Caps
Qty 2
Fixings Qty 4

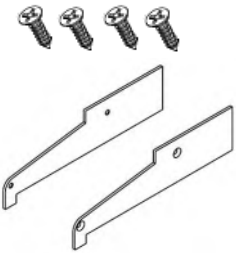

Mechanical Corner
Cleat Qty 4
(Qty 8 for loose threshold
and drip cill orders)

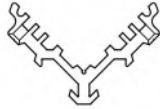

M6 x 16 Machine
Screws Qty 8
(Qty 16 for loose threshold
and drip cill orders)



Lock Keep
Qty 1

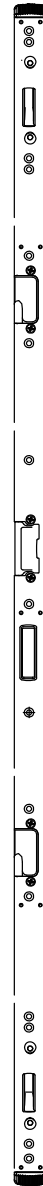

Multi Point
Door Lock
Qty 1

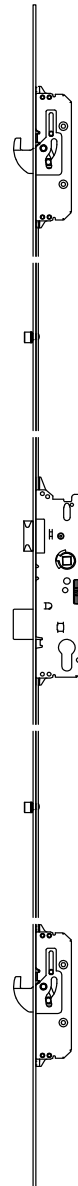

Corner Chevron
Qty 2
(Qty 4 for loose threshold
and drip cill orders)

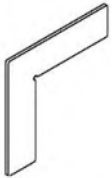

Extended Magnetic
Catch
Qty 1

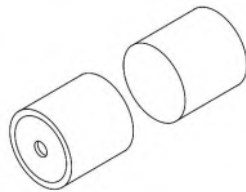

Black Bungs 12mm
Qty 8



Installation Bag Contents

A. Hardened steel direct frame fixings 7.5 x 90mm - Qty 30



B. SDS Drill bit 6.5mm x 210mm - Qty 1



C. HSS Drill bit 7mm x 105mm - Qty 1



D. Power bit 1/4 x 70mm TX30 - Qty 1



E. Insert bit 1/4 x 25 pozi No2 - Qty 1



F. Allen Key 3mm - Qty 1



G. Allen Key 4mm - Qty 1



H. Assorted bag of Packers and Wedges

VERY IMPORTANT NOTE

To speed installation, we have pre-installed some components in production.

- The Twin point lock and handles is installed into Doors 1 & 3.
- The frame jamb / Door 1 hinges are installed onto the frame jamb.
- The hinges in between Doors 1 & 2 and the top guide and bottom roller are all installed on Door 2.
- The hinges in between Doors 3 & 4 and the top guide and bottom roller are all installed on Door 4.
- The multi point lock is installed into Door 5.
- The lock keep is installed onto the locking frame jamb.

Preparing the site

Brickwork opening:

When preparing the site, please prepare the brickwork opening to be 10mm more in height and width than the outside assembled frame size.

It is essential that all 4 internal surfaces of the brickwork be levelled before installation. Please ensure that all dimensions are correct for installation before proceeding, as the set must be installed square and level into the opening.

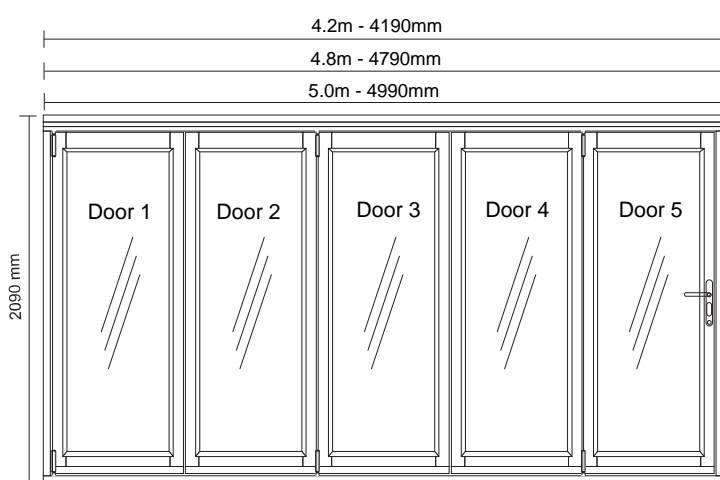
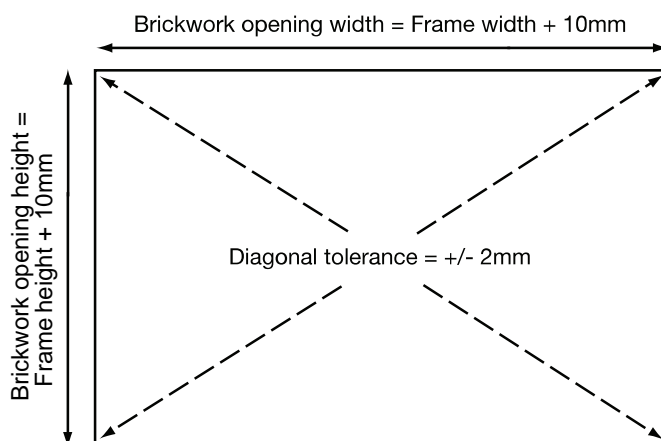

Standard sized Aluminium door sets outer frame dimensions are as follows;

- 4.2m - Door set = 4190mm wide x 2090mm high
- 4.8m - Door set = 4790mm wide x 2090mm high
- 5.0m - Door set = 4990mm wide x 2090mm high

The Brickwork opening sizes are:

- 4.2m - Door set = 4200mm wide x 2100mm high
- 4.8m - Door set = 4800mm wide x 2100mm high
- 5.0m - Door set = 5000mm wide x 2100mm high

Assembling the frame

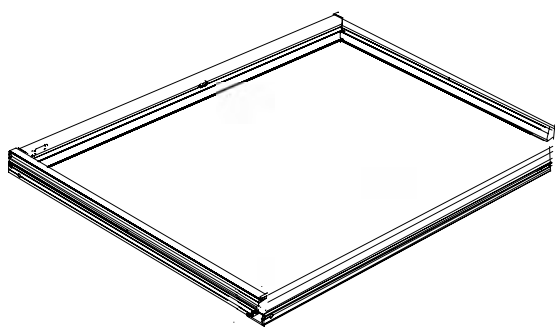

Lay all 4 pcs of the frame on top of cardboard or similar protective covering to prevent damage to the aluminium.

Identify the frame head, left and right-hand jambs and bottom threshold.

For standard door sets the threshold and cill will be integrated (1 piece).

If you have ordered an open in door set or an extended drip cill, the cill will be supplied loose and requires fitting into the opening and the frame sitting on top.

Optional trickle vents will be supplied as an 'add on' section that requires fixing to the frame head once the frame has been assembled

Please note:

For open in door sets, the frame rebate will be to the outside and hinged on the inside.

For open out door sets, the frame rebates will be to the inside, and hinged on the outside.

Assembling the frame continued

Mechanical Corner Cleat Assembly - Frame Head, jambs and *loose threshold*
(please refer to the next section for fitting of the integrated threshold / cill)

Insert the 2 corner chevrons into the grooves in the frame head (Fig 1).

Insert the mechanical corner cleats into the frame head (Fig 1).

Apply low modulus silicone sealant to the aluminium profiles to be joined together.

Carefully align the mitre joints, then using the 4mm Allen Key (G), carefully tighten the machine screws at the side and bottom. Progressively tighten all 4 machine screws, bit by bit, to ensure a tight mitre joint, then clean off any excess silicone.

Fill in the remaining smaller holes with low modulus silicone or glue as shown below (Fig 2).

Repeat the process on the opposite corner of the frame and threshold.

Frame head section

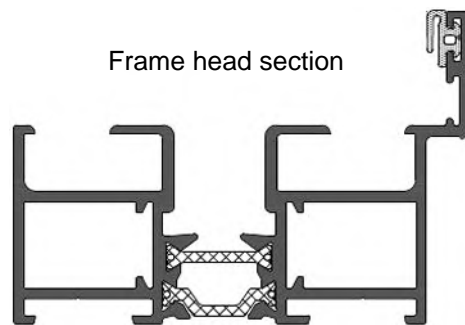

Frame jamb section
(with adjustable jamb attached)

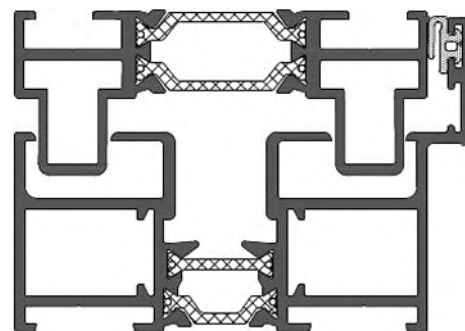

Fig 1.

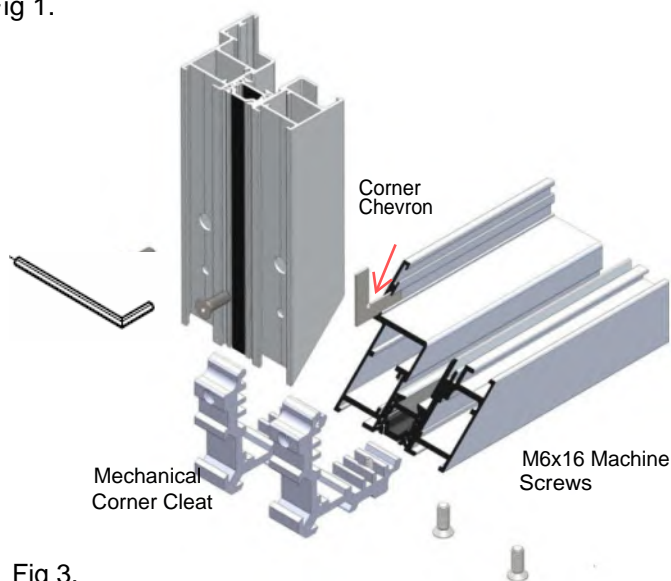

Fig 2.

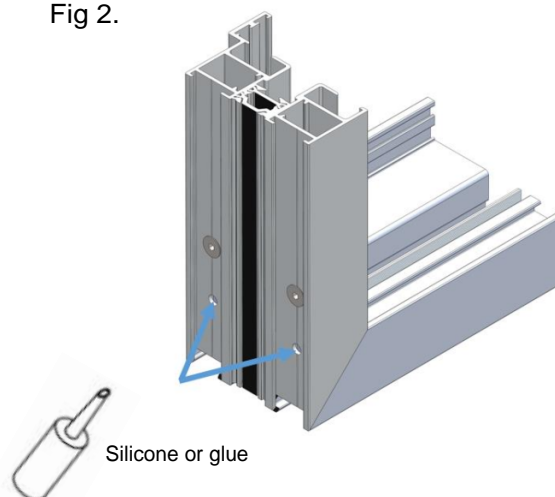

Fig 3.



Assembling the frame continued (integrated threshold / cill)

*Please skip this step if you have been supplied with a separate threshold and cill.
Please follow the cleat assembly process used above for connected the threshold and jambs.*

Insert the foam sealing block supplied into the channel of the integrated cill (Fig 1).

Before locating the jambs onto the cill, mastic seal both ends of the jambs and the face of the thermal break.

Once the jambs are aligned onto the cill, silicone dip the machine screws provided and secure (Fig 1).

Any excess silicone should be wiped off at this point.

Silicone seal both end caps onto the cill. Silicone dip the screws and fix the caps in place using the 1/4 x 25 pozi bit (Fig 3).

IMPORTANT-

Ensure no water can escape from the ends of the cill past the jambs. Any fixings breaching the drainage channel (Fig 2) must be silicone dipped.

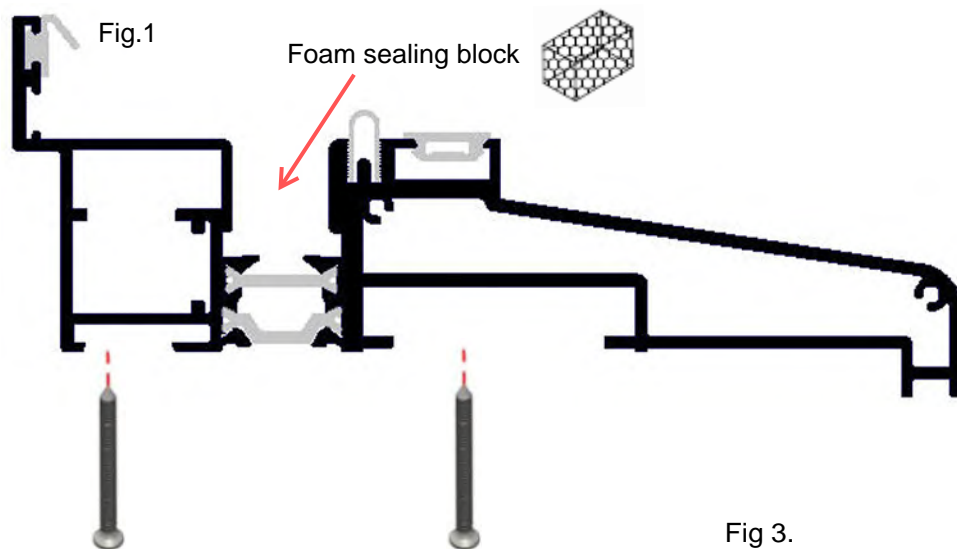
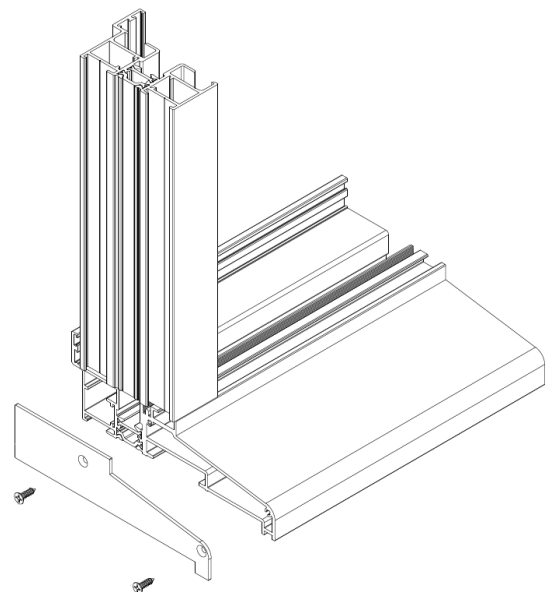
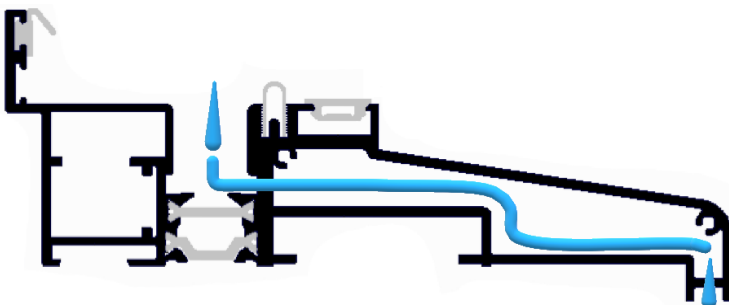

Fig 3.

Fig 2.



Fitting the optional drip cill

Please skip this step if you have been supplied with an integrated threshold / cill.

The easiest way to install the frame with a cill is to level the cill in the opening first, temporarily fixing this in place and then lift the assembled frame on top. If you have a separate drip cill, first place the cill into the bottom of the brickwork opening ensuring the bottom track section will not overhang the reveal once it is sat on top of the bottom cill.

Using a long spirit and or laser level, ensure the cill is sitting level in the opening, using the packers supplied if needed to level it. As this door is bottom rolling, it is vitally important the cill is fully supported from front to back. Packers can be kept in place using the silicone supplied.

Once the cill position is level and fully supported, use the HSS drill provided to drill a hole at each end of the cill through the thermal break. Use the SDS masonry drill supplied to drill through these holes into the masonry. Finally fix the cill in place using 2 of the direct frame fixings supplied.

Important: The cill must be sat on a bed of silicone or mortar and all fixings must be silicone dipped.

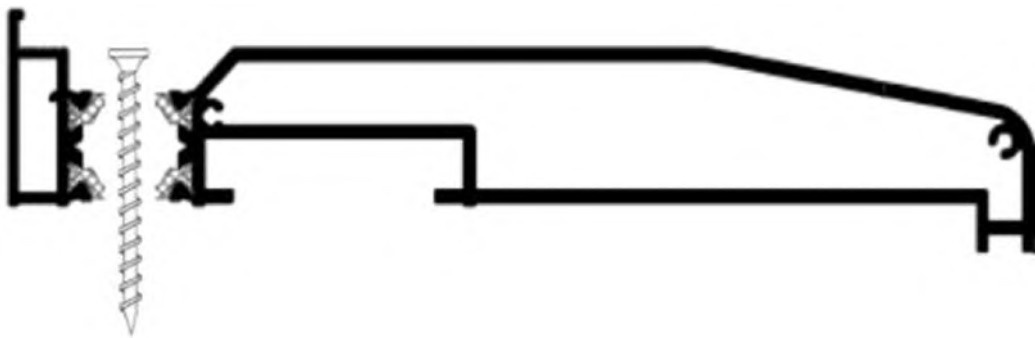

Fitting the optional trickle vent add-on

If you have ordered trickle vents, these are supplied in an aluminium add-on which sits on top of the frame head. The add-on will be supplied loose when it arrives to you, and will require screwing to the frame head before installing into the opening.

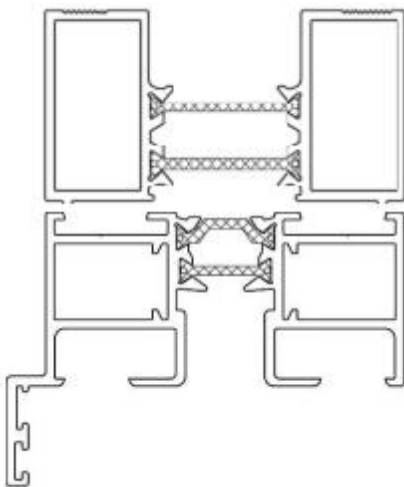

The trickle vents will be attached to the add-on and the ventilation holes pre-machined. Ensure the add-on is joined to the frame head so the canopies of the trickle vents are on the external side of the frame.



Vent fits to inside face



Canopy fits to outer face

Installing the assembled frame

The frame should be installed with the outer edge of the frame jambs up to a maximum of 5-10mm back from the face of the brickwork.

It is critical that the frame is fitted square and level.

Use the packers provided to level the frame. Start at the bottom rail and insert the first packer **DIRECTLY UNDER THE FRAME JAMB** starting at the side of the frame which looks to be the highest

The diagonals must be the same, +/- 2mm.

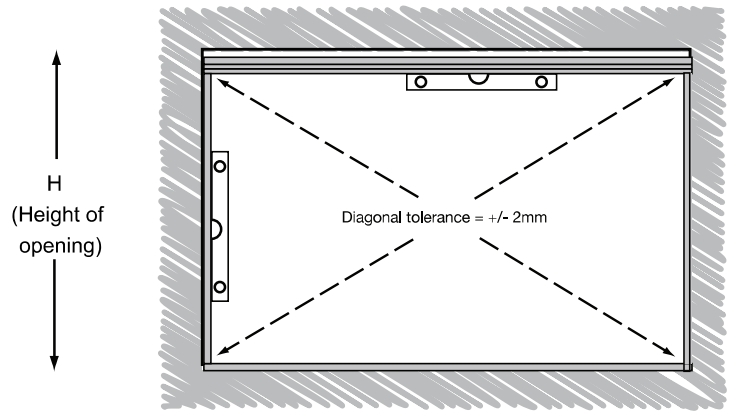

The diagonals must be the same +/- 2mm.

IMPORTANT NOTE:

The frame must be installed into the brickwork opening completely upright, square and level in every plane, before continuing with the installation. The door set uses a bottom rolling system so it is vitally important the cill is level and adequately supported by using packers as necessary.

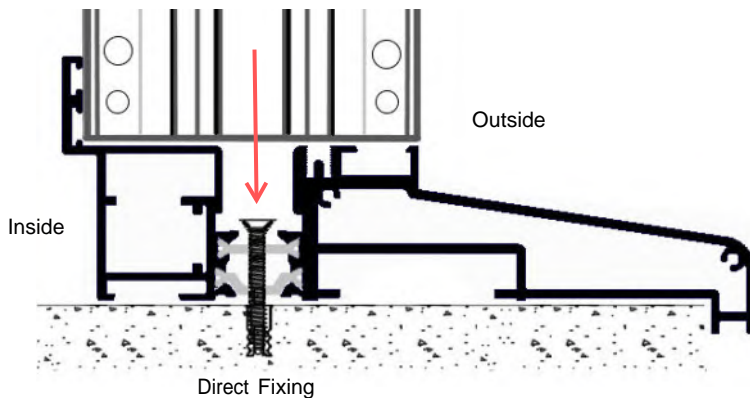

Direct fix 150mm from all corners and every 500mm maximum centres, using the hardened steel direct frame fixings provided (A).

Ensure all fixings are silicone dipped and countersunk to ensure running gear is not obstructed.

If the amount of packing is more than 4mm under the cill then reduce the maximum centres to 250mm.

Ensure you have a packer where both rollers come to rest in the closed position.

Fix directly through the cill, head and jambs into the brickwork. Holes will need to be drilled into the head cill and jambs for the fixings, using the HSS long 7mm drill provided (C).

The adjustable jambs have been pre-drilled with 13mm clearance holes to allow access to direct fix through the thermal break in the outer frame jambs. These 13mm holes should be plugged with the 12mm black bungs supplied.

For the lock keep jamb fixing, Qty 4 13mm holes are pre-drilled, 2 of which are accessible by removing the lock keep.

The hardened steel frame fixings fix directly into the brickwork without the need for plugs. After drilling the holes in the aluminium frame use the 6.5mm SDS masonry drill (B) to drill holes into the brickwork. Then fix using the hardened steel frame fixings with the T30 bit provided (D).

DO NOT OVER TIGHTEN THE FIXINGS OR DISTORT THE ALUMINIUM FRAME

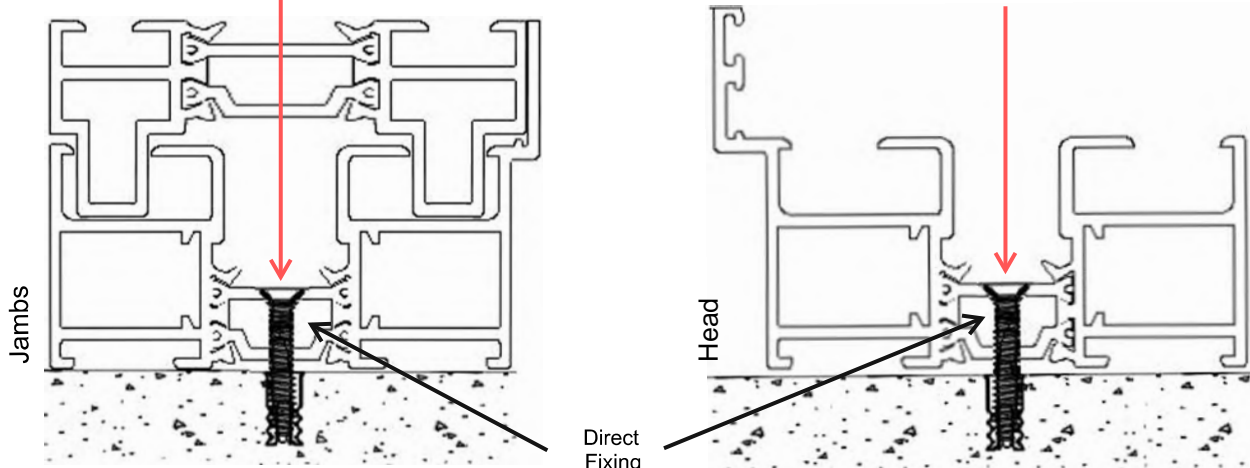

Finally apply silicone to seal all around the perimeter of the frame - especially along the complete length of the bottom cill

Fitting Door 1 to the frame jamb

Locate Door 1, which fixes to the jamb of the frame. Look for the panel glass beads to determine the interior side, and panel drainage holes to determine the bottom of the door.

Ensure the integrated cill and door are protected by using the discarded foam packaging or cardboard, and that you have a suitable support block to rest the door on.

Door 1 fixes to the frame jamb which is at the opposite side of the frame to the lock keep jamb. The hinges are already fixed to the frame jamb which just need fixing to Door 1.

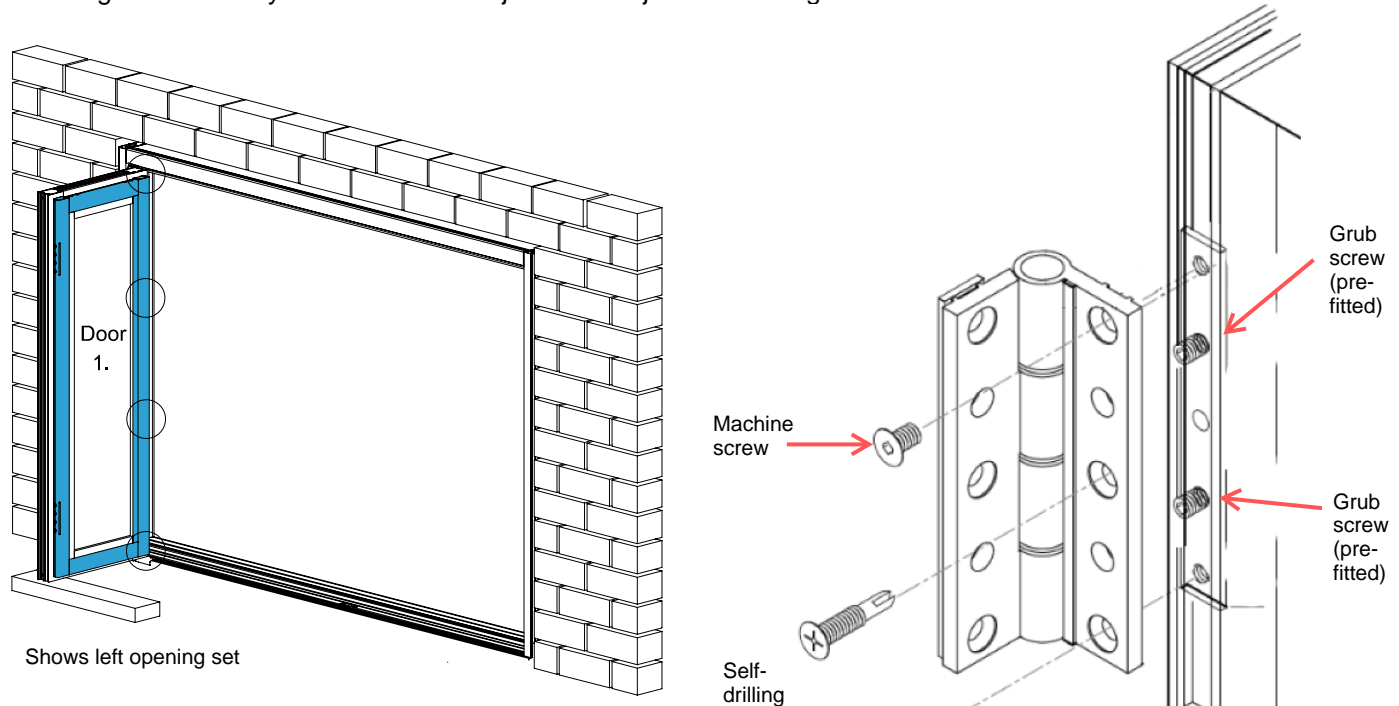

With the door at right angles and supported on blocks (being careful not to damage the seal on the bottom of the door), use the 3mm Allen key (F) and M5 x 10mm machine screws to fix the door in the top and bottom countersunk hinge hole positions.

DO NOT FIT THE 4.2 x 25MM SELF-DRILLING SCREWS AT THIS POINT.

IMPORTANT NOTE

The seal gasket is fitted under the door outside edge.

Please take care to ensure when the door rests on the block, it rests on the - ALUMINIUM PART ONLY AND NOT THE SEAL - This will prevent damage to the seal.

Fitting Door 2

Locate Door 2, paying attention to the panel glass beads and drainage holes. Door 2 has its hinges and rollers already attached.

Slightly lean the door to locate the bottom roller into the middle channel of the integrated cill (Fig 1) page 10.

Fitting Door 2

Fig.1

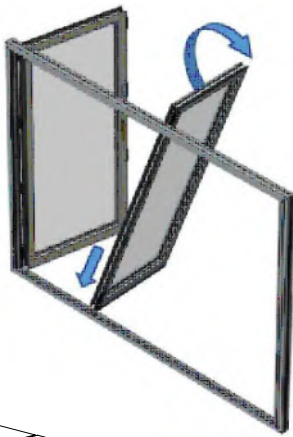

Align the top guide of Door 2 and locate it in the middle channel of the top track (Fig 2).

Move the door to the right-angle position and support on blocks, ensuring the weight is not on the door seal. (Fig 3).

Fig. 2

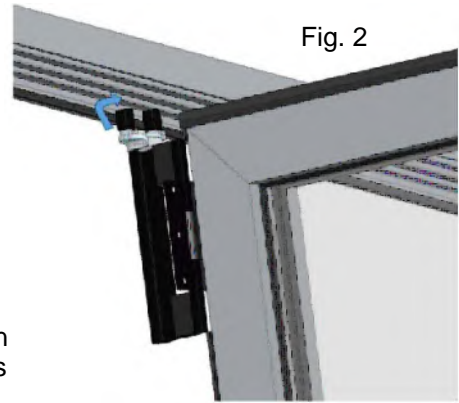
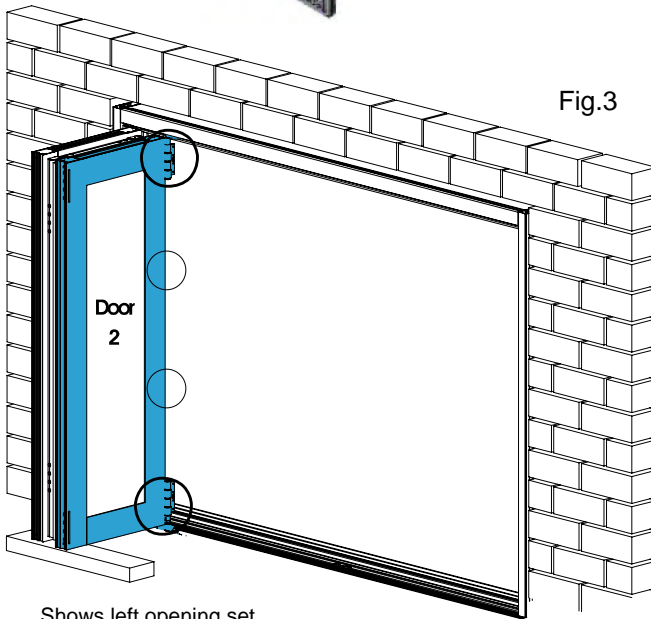

Fig.3



Shows left opening set

Fit Door 1 to Door 2 with the 4 hinges which are already fitted to Door 2 using the M5x10mm machine screws and the 3mm Allen key (F) in to each hinge leaf. Align the clamping plates with the hinges to do so. Keeping both doors on an angle (Fig 4) will allow for better access.

The hinge with the pull handle will be second down from the top.

DO NOT FIT THE 4.2 x 25MM SELF-DRILLING SCREWS AT THIS POINT.

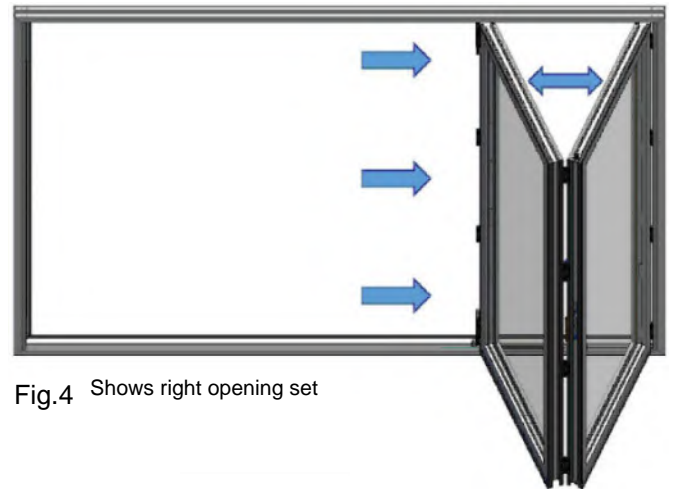
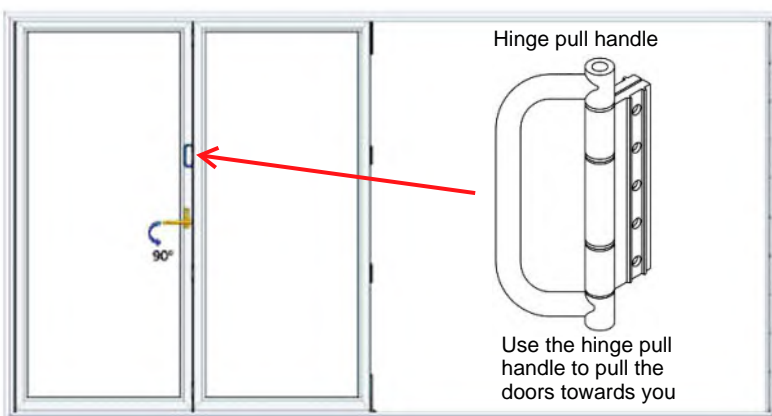
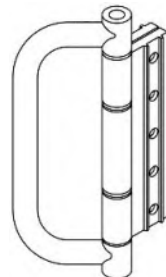

Fig.4 Shows right opening set

Close the doors from the inside using the HINGE pull handle, then rotate the intermediate twin point lock handle 90 degrees to lock the doors closed.



Hinge pull handle



Use the hinge pull handle to pull the doors towards you

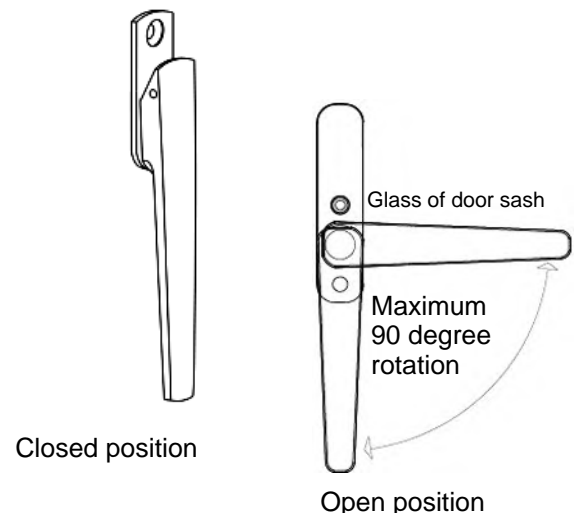

Closed position

Glass of door sash

Maximum 90 degree rotation

Open position

DO NOT USE THIS HANDLE TO PUSH/PULL THE DOOR

Fitting Doors 3 & 4

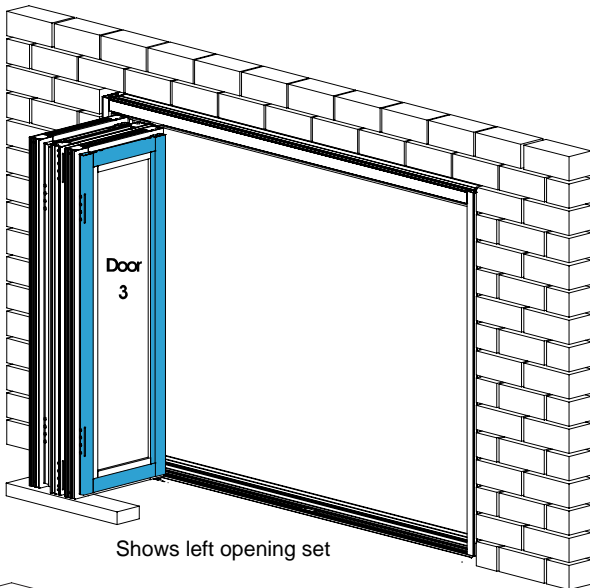

With doors 1 & 2 locked in place, support Door 3 on blocks adjacent to Door 2. Align the clamping plates with the hinges and attach the hinge leaves onto Door 3.

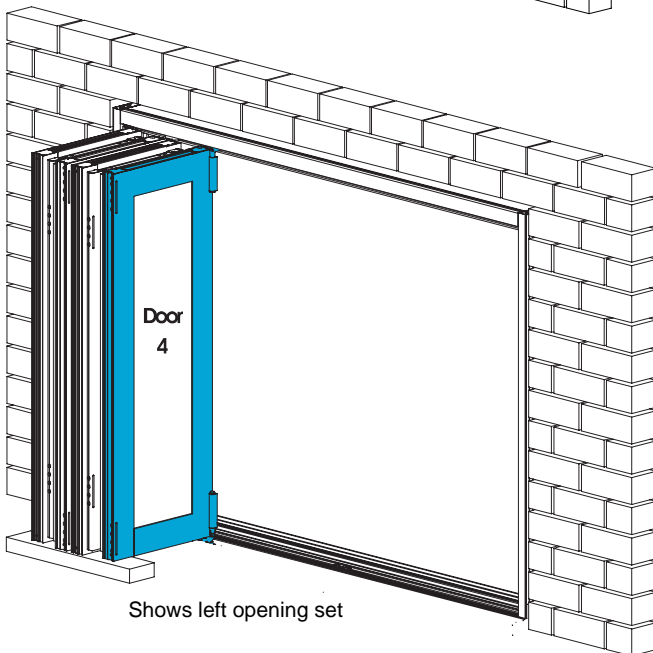

For the installation of Door 4, follow the same installation procedure as Door number 2, pages 9-10

Fitting the access door (Door 5)

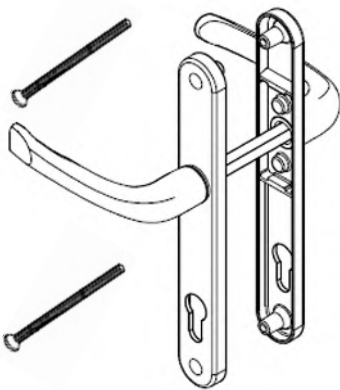

Fitting the access door (Door 5 cont)

With Doors 1, 2, 3 and 4 in the open position and at 90 degrees to the frame, support Door 5, the access door on blocks, adjacent to Door 4 and then screw the 4 hinges onto Door 5.

Alternatively you can keep Doors 1,2,3 and 4 closed, then support Door 5 at 90 degrees to the closed doors to screw the hinges onto the access door.

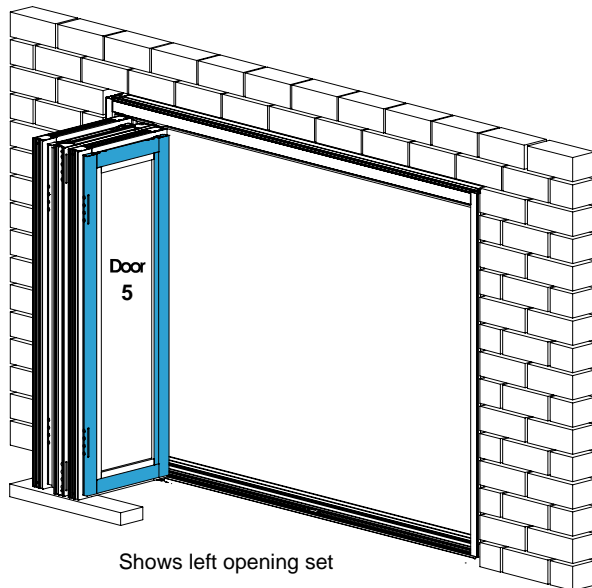

Close Doors 1 & 2 (if opened) using the HINGE pull handle and from the inside rotate the intermediate twin point lock 90 degrees to secure them in place.

Close Doors 3 & 4 (if opened) using the HINGE pull handle and from the inside rotate the intermediate twin point lock 90 degrees to secure them in place.

Close the access door, Door 5 and lift the handle to ensure the lock engages. Turn the key to fully lock the access door.

To unlock the access door use the key to unlock, then depress the handle to open the door.

IF YOU ARE HAPPY WITH THE OPERATION OF THE DOORS AT THIS STAGE AND THEY CLOSE SMOOTHLY WITHOUT CATCHING ON THE FRAMES OR LOCK KEEPS, YOU CAN NOW FIT THE SELF-DRILLING SCREWS TO EACH HINGE LEAF. IF NOT, PLEASE SEE OUR TROUBLE SHOOTING GUIDE ON PAGE 12 TO ADJUST THE DOORS TO THEIR OPTIMUM POSITION.

Fitting the magnetic catches

Threaded inner



Extended
magnetic catches

Screw the extended magnetic catches onto the threaded inner's which are located on the outside of Door 4 and 5.

Trouble Shooting Guide

Master door adjustment

- Remove the rebate profile attached to the master door to see the gap where the lock and the keep are.
- Check the distance between the locking door and the outer frame. The distance should be 13mm.

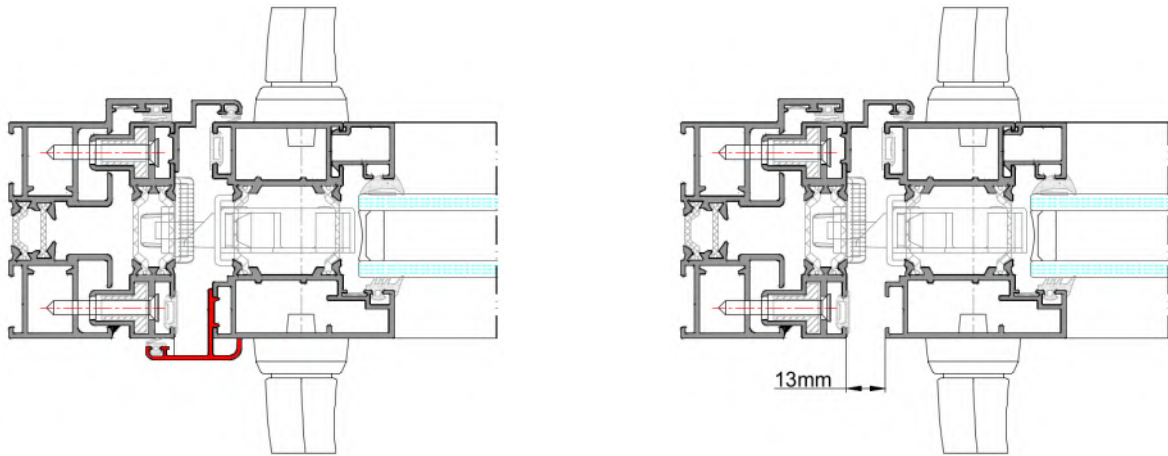

- If the lock and keep are clashing regulate the distance by adjusting adjustable jambs as shown below.
- Once the correct gap is achieved and the lock is locking perfectly fix the rebate profile back on the master door panel.
- Double check if the lock is latching properly.

Width adjustment using adjustable jambs

- To adjust the width release all bottom self-tapping screws that secures the adjustable jamb.
- Use grub screws to change the position of the adjustable jamb.
- Check the gaps to be equal and adjustable jamb is set square and level.
- After completing adjustment fix the adjustable jamb in position by securing self-tapping screws.



- Adjustable jamb is designed to have both positive and negative adjustment as shown below.

-4 mm

0 mm

+4 mm

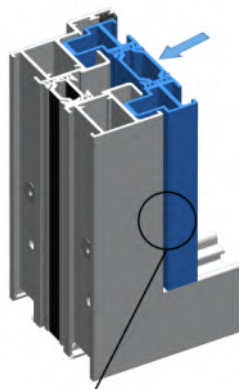

2mm Gap

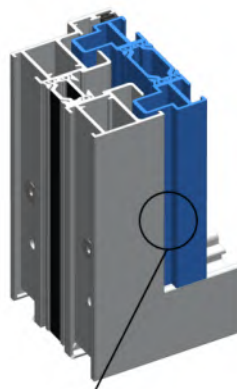

6mm Gap

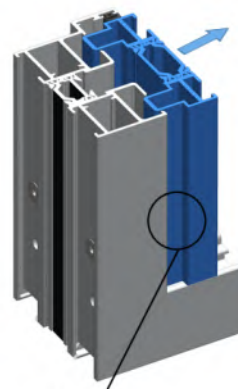

10mm Gap



Brighthouse HD6 1HA

DECLARATION OF CONFORMANCE

DoC N°: HEP/FSDALICORD

Product Type:	Aluminium Bifold Double Glazed Door
Intended Use:	For use in domestic and commercial premises Not intended for use on escape route
Declared System of Assessment Performance:	3
Provisions to which the Product Conforms:	Annex ZA of EN 14351-1:2006+A2:2016
Reference to Supporting Product Certification and/or Test Reports <i>(supportive of compliance)</i> :	BFRC Thermal Report – S158/20221018/001

Declared Performance:

Essential Characteristics

	Performance
Resistance to Wind Load:	Class A3 (1200Pa)
Watertightness:	Class 9A (600Pa)
Dangerous Substance:	No emissions of dangerous substances emitted
Load Bearing Capacity of Safety Device:	Npd
Acoustic Performance	Npd
Energy Rating:	C
Radiation Properties:	Npd
Air Permeability:	Class 4 (600Pa)

This declaration of performance is issued under the sole responsibility of Hepworth Framework Limited.

Signed for and on behalf of the Company by

Name of Representative: Richard Steckles

Job Title: Managing Director

Representative Signature:

Date of Issue: 24th February 2023

Product UKCA Marking Detail:

