

54S

Slimline Sliding Folding Patio 3 Door Set

1.8M - 1790mm W x 2090mm H

2.1M - 2090mm W x 2090mm H

2.4M - 2390mm W x 2090mm H

2.7M - 2690mm W x 2090mm H

Assembly Instructions

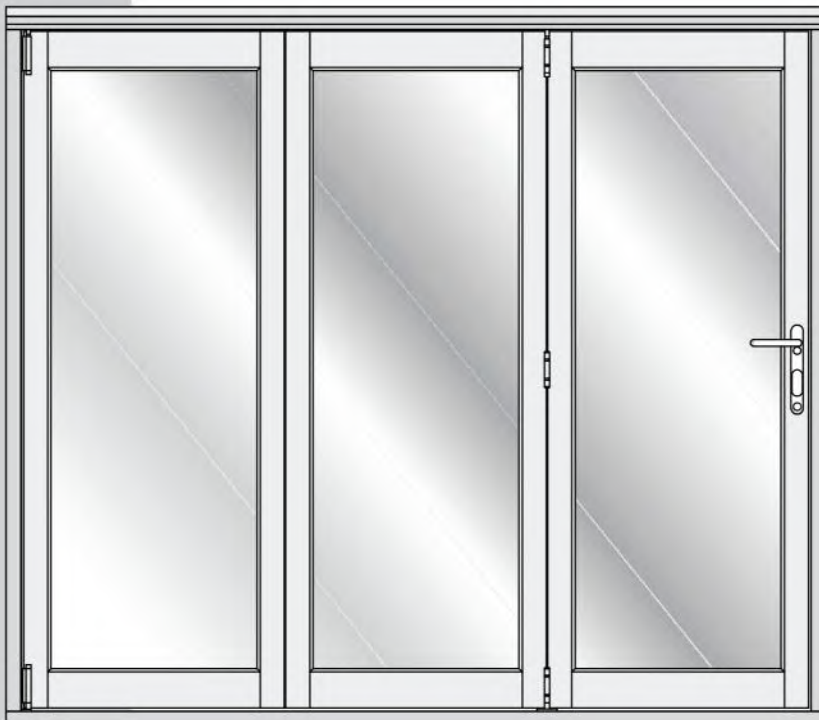

About your patio door set

All products must be installed in accordance with accepted good trade practice (and in accordance with supplied instructions where applicable), and maintained in accordance with these procedures or else the warranty shall be void.

Important information

- We recommend that a competent tradesperson install this product.
- A single person must **never** carry out the installation, as some components are very heavy.
- The Outer-Frame Head requires fixing to the building lintel over the opening. The lintel **must** be capable of carrying the load of the door in all conditions. If in doubt consult a structural engineer.

Automatic Closures and Operators

- The hardware systems are designed for manual operation. Poorly adjusted automatic operator closers can impart significant destructive forces to tracks, bearings and stops. Such hardware used in installations is expressly excluded from warranty terms.

Care of doors and frames on site

- Please check doors, frame and cill at the time of delivery to ensure that they are acceptable and in good condition, and within 72 hours of delivery. If you find a component missing or damaged please inform us immediately. We keep replacement components of most set parts and these can be sent out to you quickly. This will save you having to re-package and return the whole set, and allows you to continue with the project. (See separate parts list for component reference numbers)
- When storing prior to installation, the doors and frames should be handled with care and stored in a dry, ventilated building. Doors and frames should be stored flat and on a level surface (not on edge or on end).
- Should you need to store the doors before installation, they must still be fully inspected and checked for damage or faults and reported within 72 hours of delivery, repacking if necessary.
- Doors should not be stored or fitted in the building until the wet trades such as plastering, painting etc. have been completed and the room is dried out.

Finishing prior to Installation

- See **Pre-finishing the wooden parts** – Very important: We do not recommend wax or oil finishing systems such as Linseed oil or Teak oil.

Trimming

- This Sliding Folding Door Set is not designed to be trimmed on site and should be fitted as supplied.

Conditions of Sale

- We shall not be held responsible for any incidental work expenses arising out of or because of any defect in our product, or bad workmanship to our product. In the event of the goods having manufacturing defects and requiring replacement, our liability will be limited to the value of the door or frame component only. These notes do not affect your statutory rights with the retailer of this product.

Maintenance

Hardware in buildings is subject to deterioration from everyday use, and also environmental attack due to atmospheric and other conditions. Maintenance of hardware is even more important in severe environments such as coastal marine areas, and some industrial areas. Even stainless steel products require maintenance to prevent deterioration in some environments. We require the following minimum maintenance to be followed otherwise the warranty shall be void.

Track and Bearings:

Using a spatula or similar (not your fingers), apply a small amount (typically a 1/2 teaspoon of white petroleum jelly (Vaseline) or similar lubricant to the inner lip of each side of the track. Ensure that the wheels pass through the lubricant and it is distributed evenly along the track. Put additional lubricant around bearings. Lubricant reduces wear, improves smoothness and further protects against corrosion or track and bearings. Remove all surface contaminants by wiping all visible track surfaces with a damp soft cloth and mild detergent, then wipe clean with a clean cloth. In severe environments, apply a thin film of corrosion preventative such as WD40, by wiping with a soft cloth moistened with one of these products.

Stainless steel bearings are manufactured from hardening-grade stainless steel and although this material performs considerably better than plated steels, it is susceptible to corrosion unless maintained as described above.

Hangers, Pivots and Brackets:

A light spray application of a corrosion preventative such as WD40, followed by a light wipe with a dry cloth to remove excess, is recommended to all hangers, pivots and brackets. Exposed surfaces should first be wiped with warm soapy water and a soft rag, and then rinsed clean before applying preventative.

Hinges:

Wipe down the visible surfaces with warm soapy water on a soft rag and then rinse off by wiping with a clean damp rag. Application of a thin film of light machine oil or WD40 will help to maintain the original lustre of the metal finish. Be careful not to get these compounds on the timberwork itself as may cause staining.

Drop bolts:

Spray application of a suitable lubricant such as WD40 to the sliding pin inside the bolt and to the lock cylinder is recommended. A tube attached to the nozzle will help to concentrate the spray where you want it to go. There are access holes or slots on all drop bolt products so that this can be done without removing the locks from the doors.

Frequency:

The procedures mentioned above need to be carried out as often as is necessary to prevent deterioration in the installed environment, however we recommend the following minimum frequency of application:

General environment - 6 monthly

Marine environment - 3 monthly

Please be careful not to get the lubricants or other liquids above on the Timber components as may cause staining of the timber.

The properties of timber

No two trees produce identical grains or colour of wood and this adds to the beauty of a natural product. We therefore cannot guarantee that all doors and frame components will look exactly the same in grain and colour. Warping of wood is not a defect if it does not exceed 1/4 inch (6mm) in its installed position.

Maintaining the doors and frame

We suggest additional treatment and finishing may be required at least once a year or sooner if there is any indication of deterioration in the wood protective finish used.

Contents (1)

IMPORTANT: Please check the contents of the packages to ensure that all parts are present and in good condition before booking your installation

Timber parts

Door 1 - Pivot door - quantity 1

- 1.8m set = 1987 x 568 x 54mm
- 2.1m set = 1987 x 668 x 54mm
- 2.4m set = 1987 x 768 x 54mm
- 2.7m set = 1987 x 868 x 54mm

- 54PFO06S-1/54PFW06S-1/54PFG06S-1/54SDPFO06S-1
- 54PFO07S-1/54PFW07S-1/54PFG07S-1/54SDPFO07S-1
- 54PFO08S-1/54PFW08S-1/54PFG08S-1/54SDPFO08S-1
- 54PFO09S-1/54PFW09S-1/54PFG09S-1/54SDPFO09S-1

Door 2 - Mid door - quantity 1

- 1.8m set = 1987 x 568 x 54mm
- 2.1m set = 1987 x 668 x 54mm
- 2.4m set = 1987 x 768 x 54mm
- 2.7m set = 1987 x 868 x 54mm

- 54PFO06S-2/54PFW06S-2/54PFG06S-2/54SDPFO06S-2
- 54PFO07S-2/54PFW07S-2/54PFG07S-2/54SDPFO07S-2
- 54PFO08S-2/54PFW08S-2/54PFG08S-2/54SDPFO08S-2
- 54PFO09S-2/54PFW09S-2/54PFG09S-2/54SDPFO09S-2

Door 3 - Access door - quantity 1

- 1.8m set = 1987 x 568 x 54mm
- 2.1m set = 1987 x 668 x 54mm
- 2.4m set = 1987 x 768 x 54mm
- 2.7m set = 1987 x 868 x 54mm

- 54PFO06S-3/54PFW06S-3/54PFG06S-3/54SDPFO06S-3
- 54PFO07S-3/54PFW07S-3/54PFG07S-3/54SDPFO07S-3
- 54PFO08S-3/54PFW08S-3/54PFG08S-3/54SDPFO08S-3
- 54PFO09S-3/54PFW09S-3/54PFG09S-3/54SDPFO09S-3

Top frame Head

includes aluminium top track
- quantity 1

Side frame sections (jambs)
- quantity 1 Set

Sill bottom section
includes aluminium bottom track
- quantity 1

- 54PFO06S-4/54PFW06S-4/54PFG06S-4/54SDPFO06S-4
- 54PFO07S-4/54PFW07S-4/54PFG07S-4/54SDPFO07S-4
- 54PFO08S-4/54PFW08S-4/54PFG08S-4/54SDPFO08S-4
- 54PFO09S-4/54PFW09S-4/54PFG09S-4/54SDPFO09S-4

Drop bolt keyed - quantity 1
Keyed drop bolt
fixing pack - quantity 1 pack
Includes drop bolt cup



Drop bolt non keyed - quantity 1
Non-keyed drop bolt
fixing pack - quantity 1 pack
Includes drop bolt striker plate

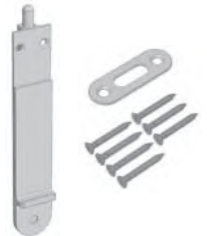

Blank plate and driver pack - quantity 1
Blank plate
fixing pack - quantity 1 pack



Hardware E22M3LRSTS

Top pivot - quantity 1

Top pivot fixing pack - quantity 1 pack



1D600

Door handles - quantity 1 Set

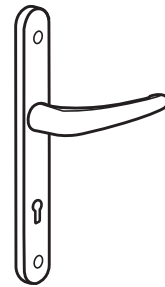

Bottom pivot - quantity 1

Bottom pivot fixing pack - quantity 1 pack

6402-85

Hook bolt keeps -
quantity 2



Half offset hinges - quantity 3

Half offset hinges
fixing pack - quantity 1 pack

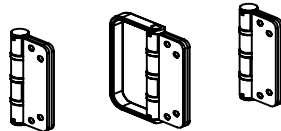

6401-101-85

Centre lock keep -
quantity 1



9935-619-85ZV

3 Point Bi-fold hook lock
quantity 1



Intermediate carrier - quantity 1

Intermediate
fixing pack - quantity 1 pack

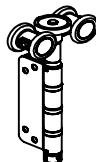

6401-72-85

Latch plate -
quantity 1

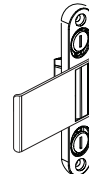

Straight Hinge - Quantity 1

Straight Hinge
fixing pack - quantity 1 pack

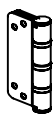

6401-spacer

Plastic spacers - quantity 2



Intermediate guide - quantity 1

Intermediate guide
fixing pack - quantity 1 pack

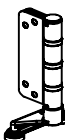

6402-102-85
Hook bolt
blank keeps -
quantity 2



6401-102-85
Centre lock
blank keep -
quantity 1



Contents (2)

Please check the contents of the packages to ensure that all parts are present before beginning assembly.

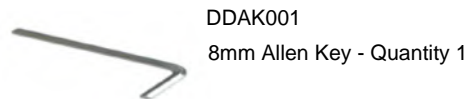

Optional extras

EWMP
Magnetic catches
Plastic magnetic door holders
- quantity 1 set

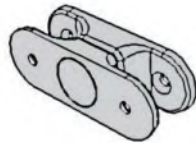

DDDS035
Metal door holder
- quantity 1 set



K71570911(38)

Installation Bag Contents

Hardened steel wood screws pozi flat countersunk yellow



A) M5 x 60mm - quantity 4

B) M5 x 70mm - quantity 4

C) M5 x 100mm - quantity 4

D) 1/4 Hex pozi No.2 insert bit - quantity 1



E) Hardened steel frame fixings - quantity 22



F) HSS long drill bit 6.5mm x 148mm - quantity 1

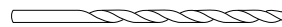

G) SDS drill bit 6.5mm x 160mm - quantity 1

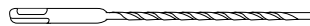

H) 1/4 Hex T30 insert bit - quantity 1



I) Steel cross recess mushroom head bolt zinc
M6 x 80mm - quantity 14

J) Steel M6 nuts zinc - quantity 14

K) Hardened steel wood screws pozi flat countersunk
M4 x 40mm - quantity 37



L) Cover caps
Brown - quantity 10
White - quantity 10
Grey - quantity 10



M) A2 Machine screws Philips raised countersunk
brused chrome
M5 x 65mm - quantity 2



Seals



	1.8m	2.1m	2.4m	2.7m	
Draft seal AQ21	2.3 metres x 6	2.3 metres x 6	2.3 metres x 6	2.3 metres x 4 3.5 metres x 2	AQ21BLK2.3 AQ21BLK3.5
Draft seal Brush seal	2.3 metres x 1	2.3 metres x 1	2.3 metres x 2	2.3 metres x 2	brushseal2.317



Draft seal AQ63	2 meters x 4	2 meters x 4	2 meters x 4	2 meters x 4	AQ63BLK2
------------------------	--------------	--------------	--------------	--------------	----------

Adhesive Seals



	1.8m	2.1m	2.4m	2.7m
QL3116BLK	100mm x 2	100mm x 2	100mm x 2	100mm x 2
AQ122BLK	100mm x 6	100mm x 6	100mm x 6	100mm x 6

For sets factory pre-finished

Please see the separate booklet (Home owners manual) with detailed information and maintenance guidelines.

Preparing the site

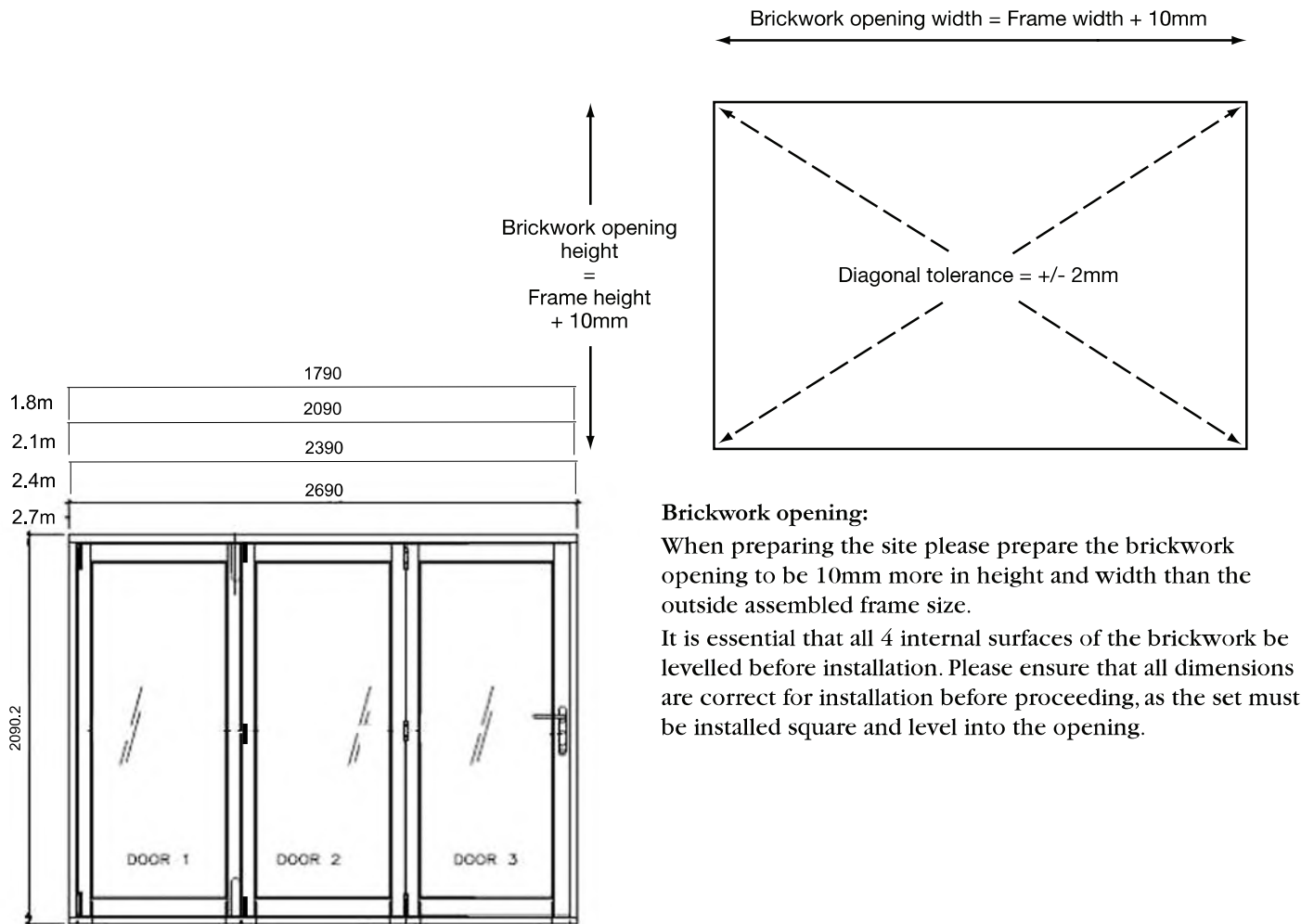

The Sliding Folding Door Set assembled outer frame sizes are as follows:

- 1.8m = 1790mm Wide x 2090.2mm High
- 2.1m = 2090mm Wide x 2090.2mm High
- 2.4m = 2390mm Wide x 2090.2mm High
- 2.7m = 2690mm Wide x 2090.2mm High

The recommended brickwork openings are as follows:

- 1.8m = 1800mm Wide x 2100mm High
- 2.1m = 2100mm Wide x 2100mm High
- 2.4m = 2400mm Wide x 2100mm High
- 2.7m = 2700mm Wide x 2100mm High

Assembling the frame

1 Fix right and left frame jambs to the frame head using wood screws provided. 100mm(A) at back, 70mm(B) in centre and 60mm(C) at front and using Pozi No 2 insert bit (D) Apply a bead of silicone sealant to the touching joint surfaces before assembly.

2 Fix cill to the left and right jambs using the wood screws provided - 100mm(A) at back, 70mm(B) in centre and 60mm(C) at front and using pozi No 2 insert bit (D) Apply a bead of silicone sealant to the touching joint surfaces before assembly.

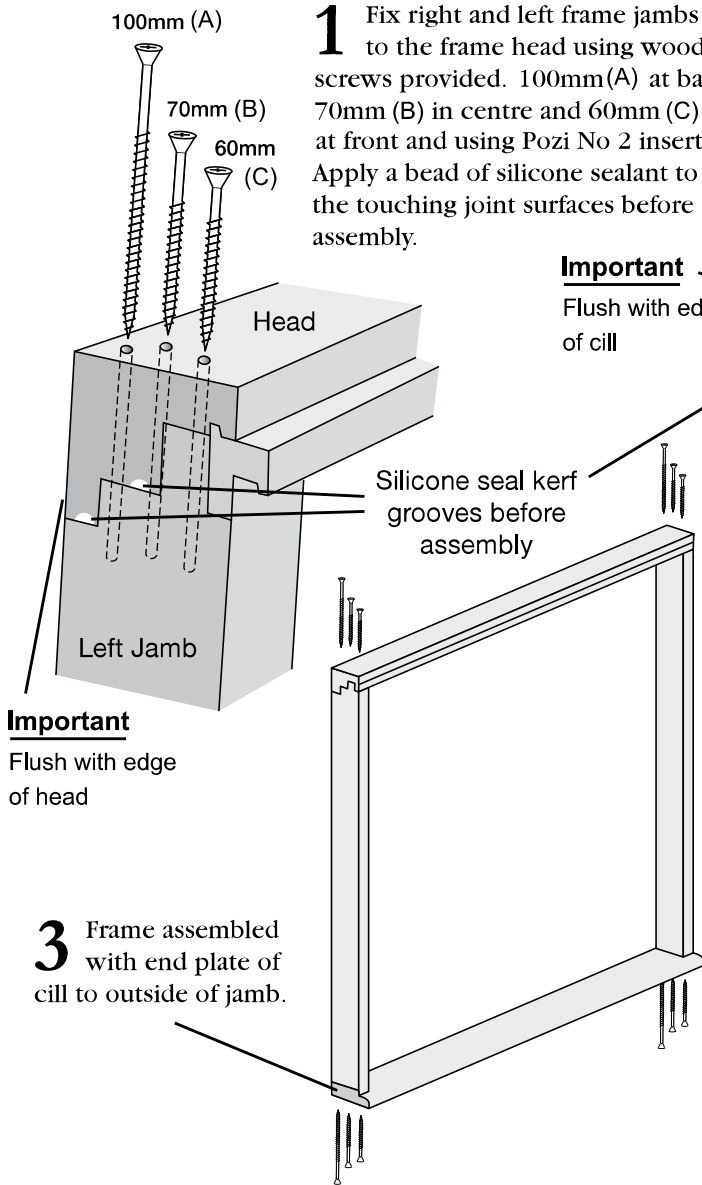

Important

Flush with edge of cill

Important

Flush with edge of head

3 Frame assembled with end plate of cill to outside of jamb.

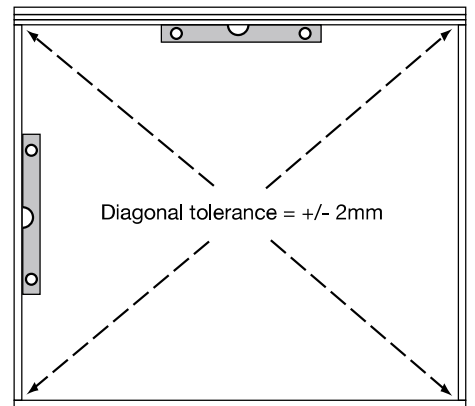
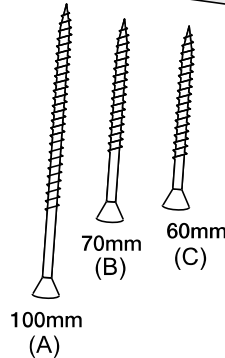
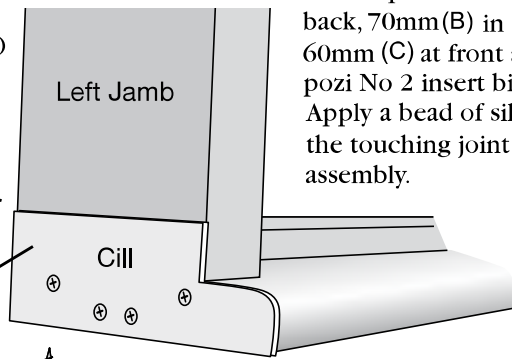

4 Very Important. Carefully check frame is tightly fixed together and is square. Diagonals of frame must be equal +/- 2mm. *Do not proceed with the installation if the frame is not square.*

Opening options

5 Choose the opening direction before installing the frame. The Tri-fold door set is reversible, with left or right opening options. Before assembling the frame or fitting the doors, choose the direction you wish the doors to open. This will determine which instructions, **A** or **B**, to follow and which door to fit first. (The Tri-fold doors always open outwards.)

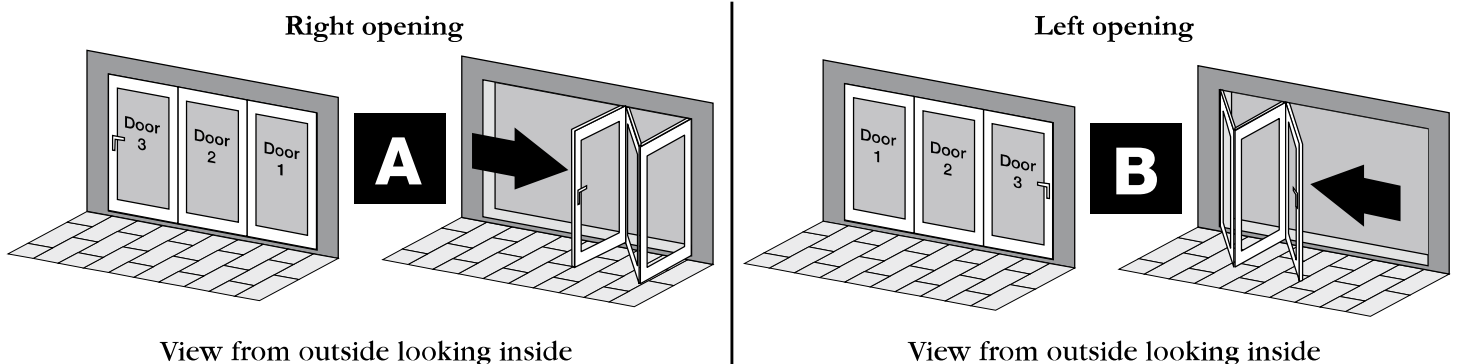

Follow the appropriate instructions for your choice of opening. Follow **A** for Right opening. Follow **B** for Left opening.

Assembling the top track

A Instructions for Right opening

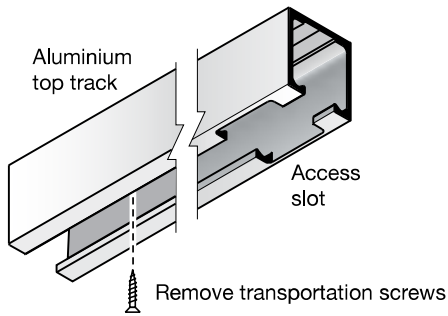

6a Remove the two transportation screws to release the aluminium top track from the frame head.

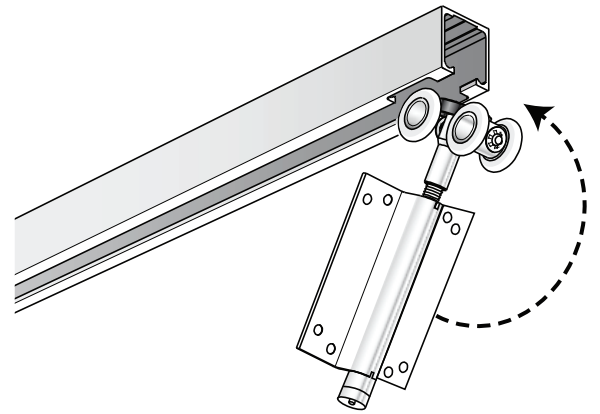
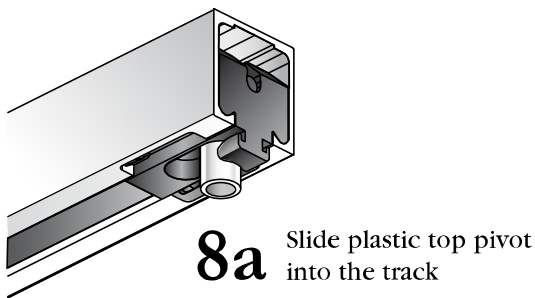

7a Slide the intermediate carrier wheels into the track.

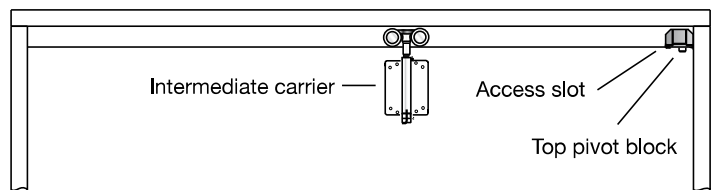

9a Re-secure the top track to the frame head using the two transportation screws *only* at this stage.
Important - The track access slot is on the right

Assembling the top track

B Instructions for Left opening

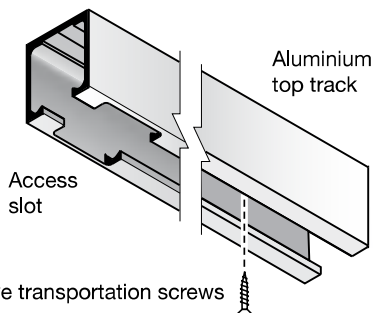

6b Remove the two transportation screws to release the aluminium top track from the frame head.

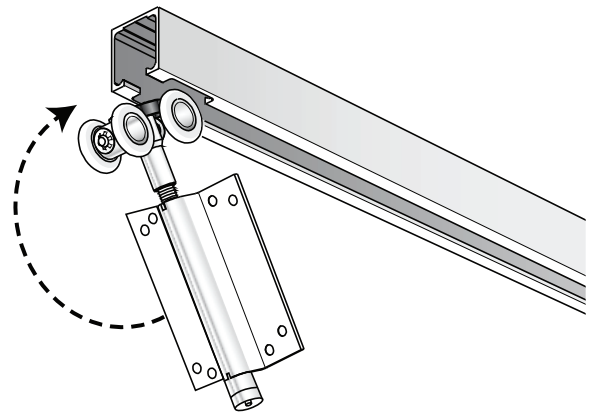
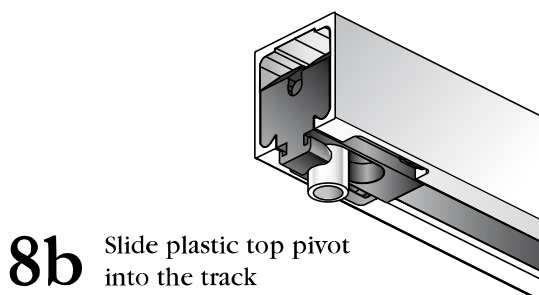

7b Slide the intermediate carrier wheels into the track.

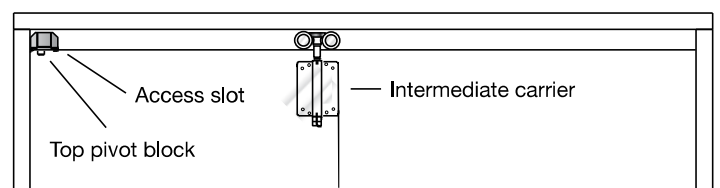

9b Re-secure the top track to the frame head using the two transportation screws *only* at this stage.
Important - The track access slot is on the left

Installing the assembled frame

10 Proceed to install the assembled frame ensuring that the cill faces to the outside. **It is critical that the frame is fitted square and level** with tolerances as follows. Ensure the frame is installed straight and square using shims/packers (not provided) between the frame and the brickwork opening

The height (H) must be the same across the whole width of the opening +/- 2mm.

The diagonals must be the same +/- 2mm.

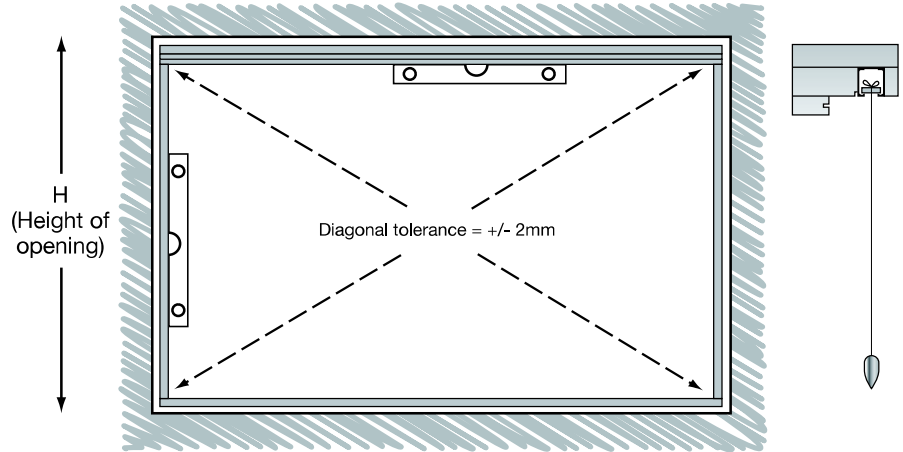

Fix the outer frame into the brickwork, normally installed 5-10mm back from the outer face of the brickwork, setting it to overhang the cavity if possible.

Fix through the outer frame into the brickwork through both jambs, with 5 fixings at spacing shown using the direct frame fixings (E) provided (unless the construction of your building requires more appropriate fixings to suit the individual dwelling). Countersink holes in the frame.

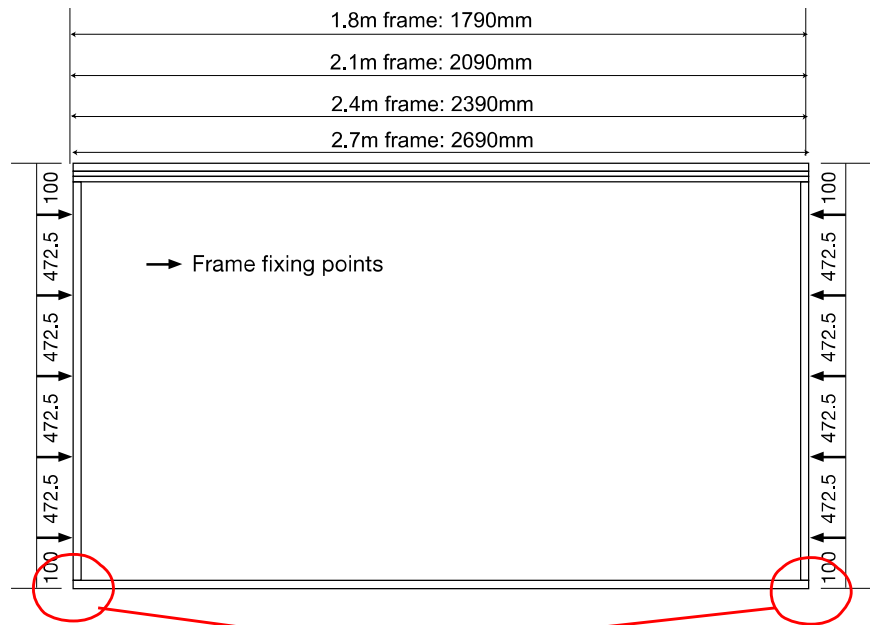

Use the direct frame fixings (E) as follows:

- 1) Use the 6.5mm HSS drill (F) to drill holes in the frame jambs, aluminium track and steel.
- 2) Use the 6.5mm SDS masonry drill (G) to drill into brickwork.
- 3) Use the torx 1/4 hex T30 bit (H) to screw in the direct frame fixings (E).
- 4) Cover using white, brown or grey cover ups (L).

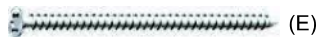

Do not fix through the aluminium part of the cill as this may damage the drainage system.

You do not need to screw down through the cill, however should you wish to it is possible to countersink a fixing into the drop bolt cup cut out. It is important to seal this with silicone.

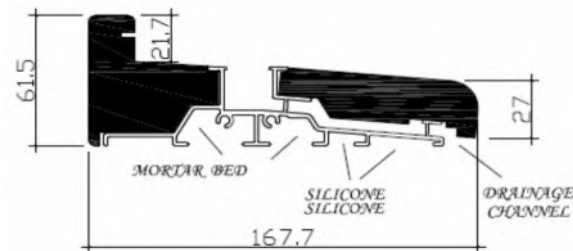
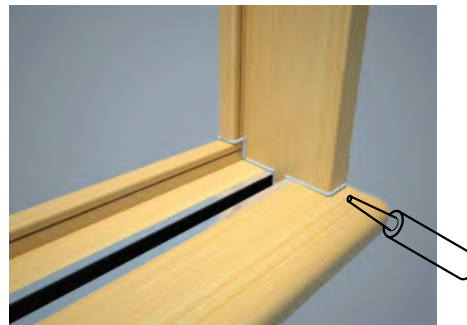

IMPORTANT NOTE

After the frame is installed, Silicone Seal around the base of the frame jamb/Cill joint as shown in the drawing

Important information about direct frame fixings

The direct frame fixings (E) supplied will screw directly into brickwork and up to 2.5mm thickness of steel. It is essential to use the 6.5mm drills (F) & (G) and torx hex T30 bit (H) provided to ensure a secure fixing.



Installing the assembled frame (continued)

HIGH IMPORTANCE: The Set is 'Top Hung, so it is vitally important to fix through the top track and frame head into the Lintel (11a and b)

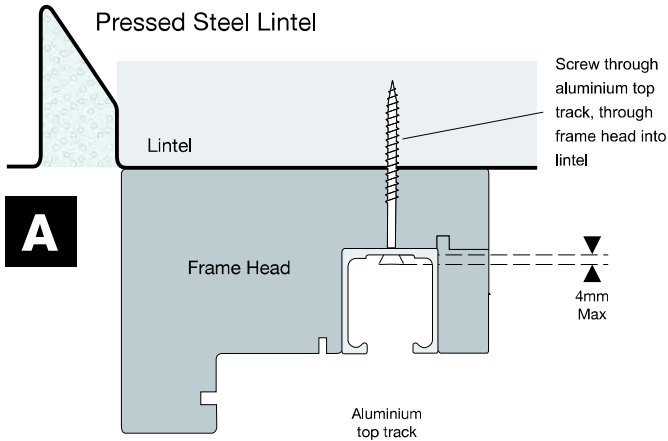

11 The aluminium top track, which is temporarily held in place with transit screws, has been pre-drilled for fixing points to the lintel. The aluminium track must be securely fixed, through the head of the frame, into the lintel using either the direct frame fixings (E) or nuts, bolts and washers (I) & (J) provided.

A Use the direct frame fixings (E) as follows:

- 1) Locate the pre-drilled holes in the aluminium top track.
- 2) Remove the transportation screws from track.
- 3) Use the 6.5mm HSS drill (F) to drill through the pre-drilled holes, through timber frame head and into the pressed steel track.
- 4) Use the 6.5mm SDS masonry drill (G) to drill through the same holes into brickwork above the lintel.
- 5) Use the torx 1/4 hex T30 bit (H) to screw in the direct frame fixings (E).

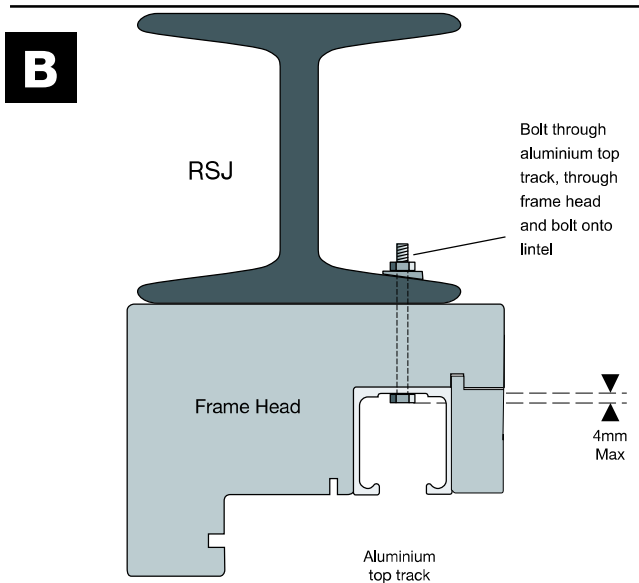

B Use the nuts, bolts and washers (I) & (J) as follows:

- 1) Locate the pre-drilled holes in the aluminium top track.
- 2) Remove the transportation screws from track.
- 3) Use the 6.5mm HSS drill (F) to drill through pre-drilled holes, through the timber frame head and through the RSJ.
- 4) Use the nuts, bolts and washers (I) & (J) provided to fix the track and frame head to the RSJ.

IMPORTANT: We strongly recommend 'B' type fixing to an RSJ. If using 'A' type fixing to pressed steel lintel, ensure the lintel can support the weight of the set (6ft, 7ft, 8ft & 9ft only.) Fixings must fix through the aluminium track, frame head and lintel. (The folding sliding system is 'top hung' so all the weight is supported from the lintel, hence the importance of fixing into the lintel, to enable the system to work correctly.)

Fitting the seals to the frame

12 Once the frame is fixed into place, fit the weather seals (AQ21) to the frame and the brush seal into the frame head.

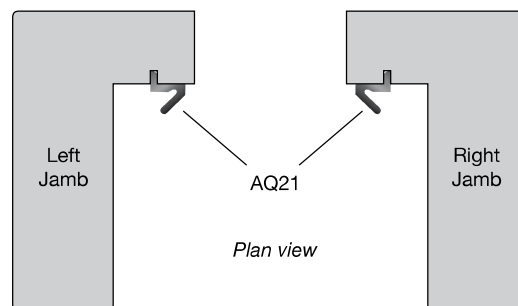
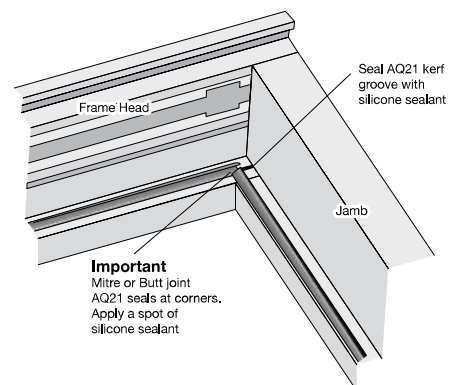
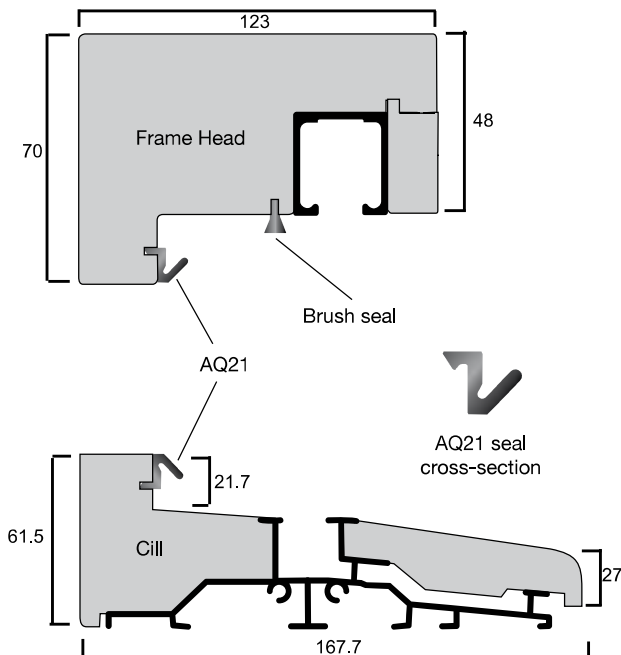

Overview of door and hardware arrangement

13a

Choice **A** for Right opening

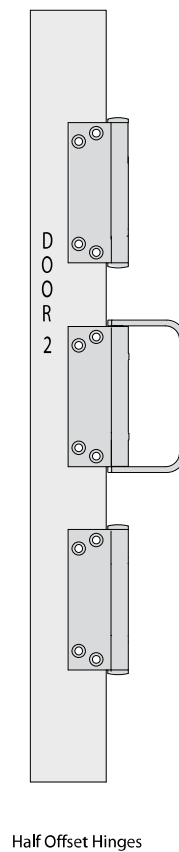
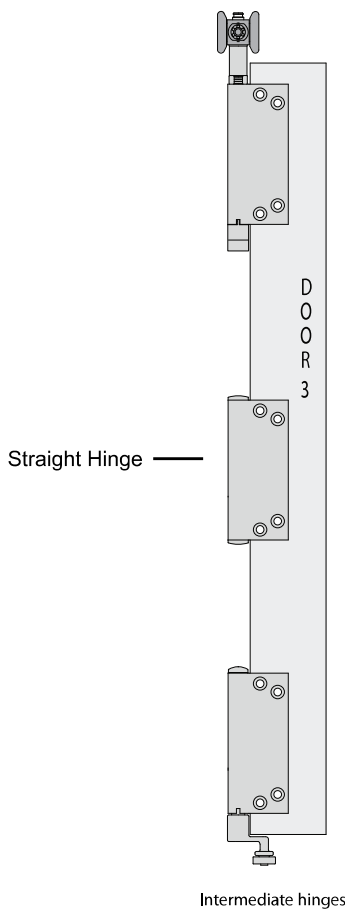
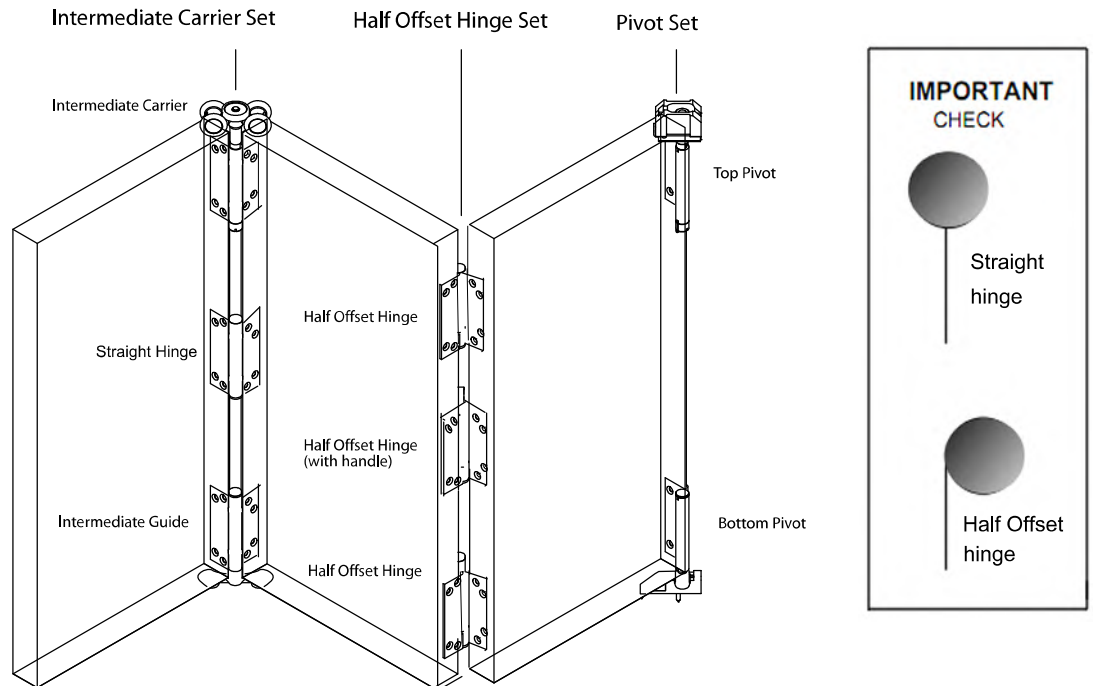

Note: Pivots are reversible. For this option 'A' it is necessary to take the top and bottom pivots apart to reverse them - see 16

Overview of door and hardware arrangement

13b

Choice **B** for Left opening

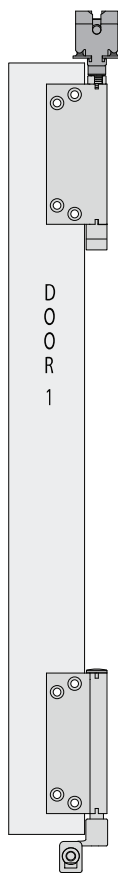
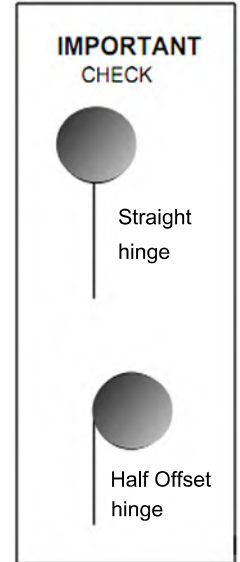
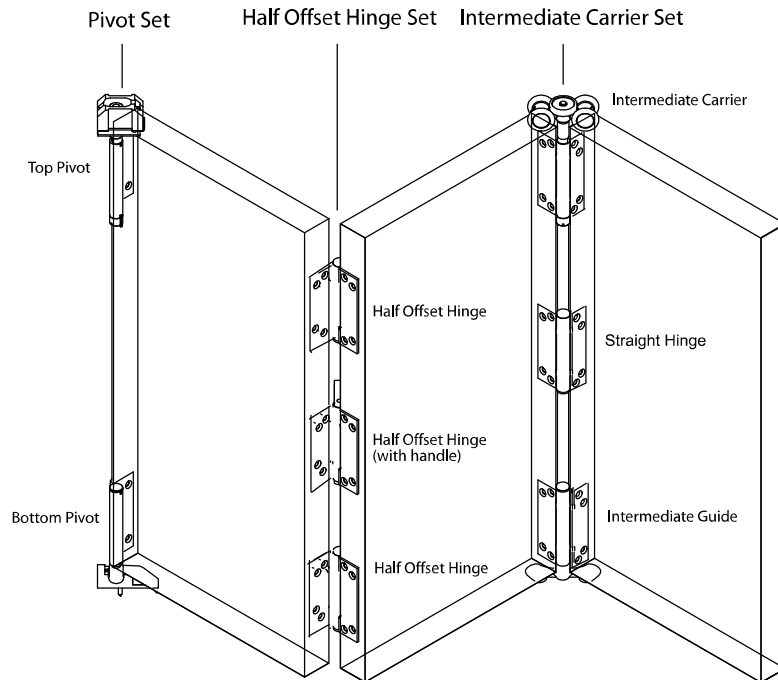

Pivot Hinges

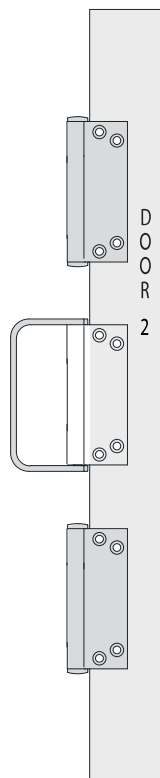

Half Offset Hinges

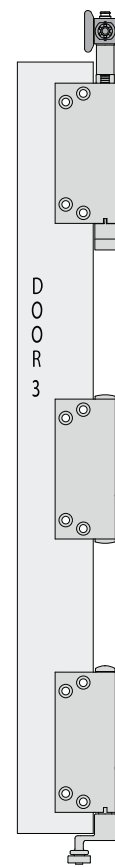

Intermediate hinges

— Straight Hinge

Note: Pivots are reversible. The pivots are delivered set up for this option 'B' - Use without change.

Fitting the dropbolts

14 Fit the keyed drop bolt to the bottom of door 1 using the pre-cut position.

Fit the non-keyed drop bolt to the top of door 1 using the pre-cut position.

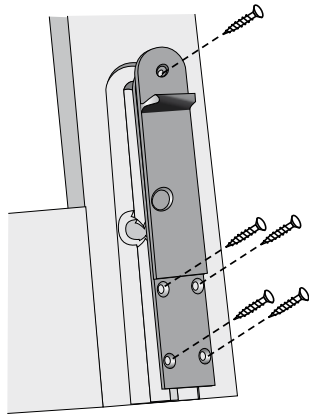

15 Fit the keyed drop bolt cup to the cill in the pre-cut position.

Fit the non-keyed drop bolt striker plate to the frame head in the pre-cut position.

Use the blank plates to cover the unused pre-cut positions.



Fitting the pivot door (door 1)

Before fitting door 1 thoroughly clean the top and bottom tracks

16 Reversing top pivot - Applicable to option **A** only. Carefully remove centre bolt from hinge barrel then re-insert from the other end.

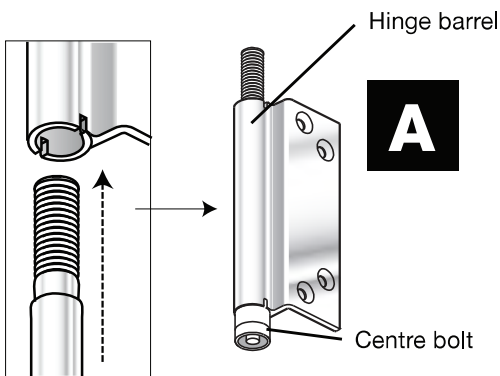

17 Fix top and bottom pivot hinges to door 1 using screws supplied in pre-machined positions.

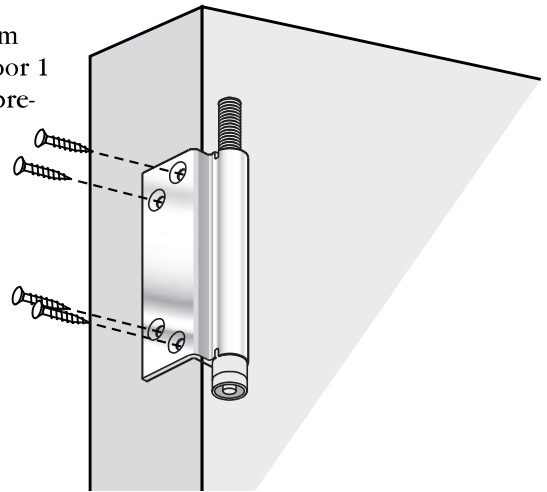

18 Assemble top pivot block. Slide and click cover plate onto the pivot block. Screw through cover plate into rear of access slot ensuring the pivot block is sitting tight up against the frame jamb.

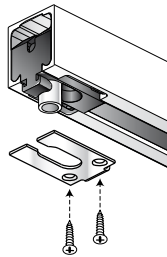

19 Remove centre part of bottom pivot

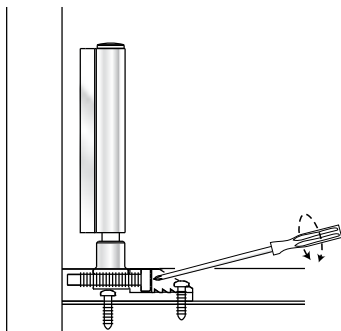

20 Insert pivot base into cill channel. Drill pilot hole in channel and fix with self-tapping screw. Re-assemble centre part with pivot to **outside**. Drill second pilot hole and fix with self-tapping screw through complete unit ensuring the pivot block is sitting tight up against the frame jamb.

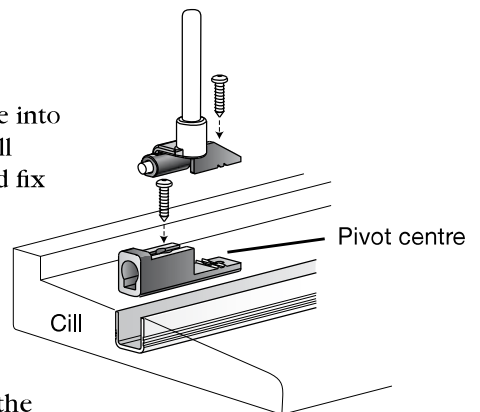

Fitting the pivot door (door 1) *continued*

- 21** Lift door onto bottom pivot. Support door then screw top pivot centre bolt into pivot block until door swings freely.

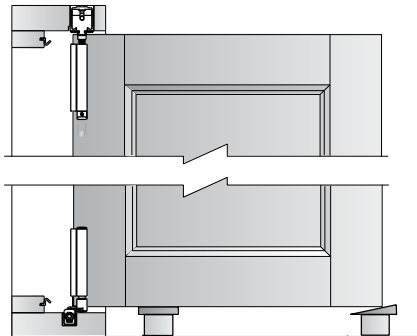

Temporary supports

Note: Screwing top pivot bolt in and out adjusts height.

- 22** Adjust alignment of pivot door as shown. Leave a 7mm gap between the door edge and the frame jamb.

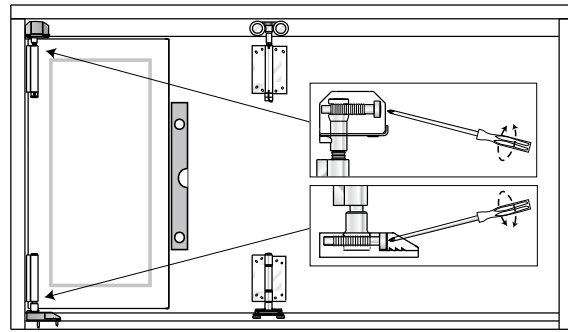

- 23** Fit the half offset hinges to the inside edge of door 1. Fix through small centre part of hinges using the Torx head screws provided in the pre-drilled holes.

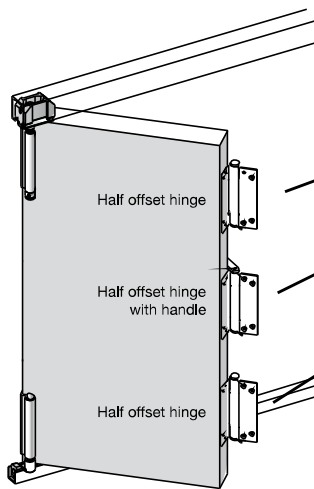

IMPORTANT- Check
Half offset hinge



NOTE: Hinge barrels and centre hinge handle to inside.

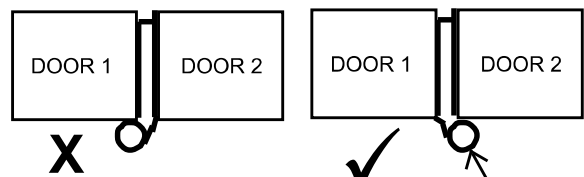

VERY IMPORTANT
Offset Hinge Barrel must be on Door 2

Fitting the middle door (door 2)

- 24** Fix the Intermediate Carrier Set to Door 2 only, using the machined hinge positions and screws provided.

- 25** Lift door 2 and locate intermediate guide in bottom channel. Support door on blocks then screw top carrier bolt into top wheel assembly.

Finally fix door 1 and 2 together using the half offset hinges fitted into the machined positions.
Note: Handle to inside and Glazing bead side of the door to the inside.

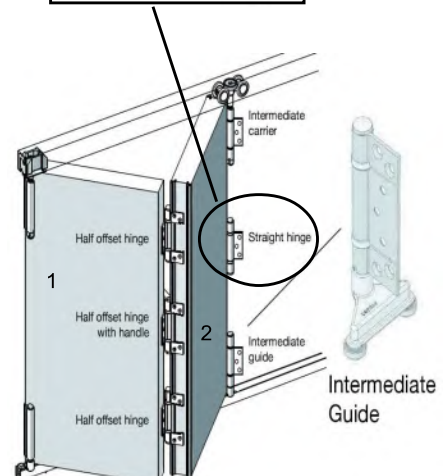
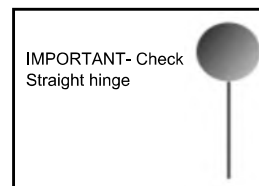

Fitting the access door (door 3)

26 Attach door 3 to the Intermediate Carrier and Intermediate Guide in the pre-machined positions using the screws provided. Use the Straight Hinge in the central position.

Drawings in this section show the arrangement of parts for Opening Option **B**

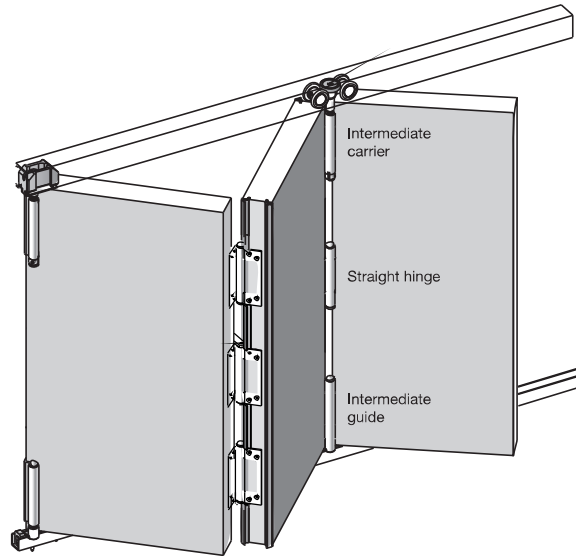

Fitting the weather seals to the doors

27 Fit weather seals to doors as follows:

- 1 strip type AQ21 to door 1
- 4 strips type AQ63 to door 2
- 1 strip type AQ21 to door 3

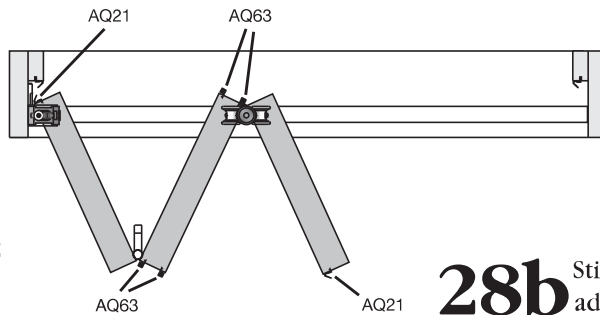
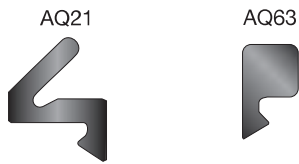

28a Stick the 2pc self adhesive seals QL3116BLK onto the top and bottom pivot hinge plate in line with the AQ21 Seal.

28b Stick the 6pc self adhesive seals AQ122BLK onto the hinge plates of the Half offset hinges and intermediate carrier and guide, in line with the AQ63 Seal.

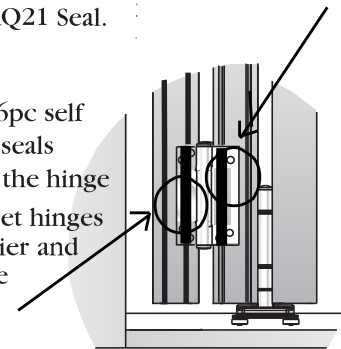

Adjusting the operation of the doors

29 Raise or lower the height of the doors by adjusting the top pivot and intermediate carrier.

Insert the Allen Key provided then turn clockwise to raise and anti clockwise to lower the doors.

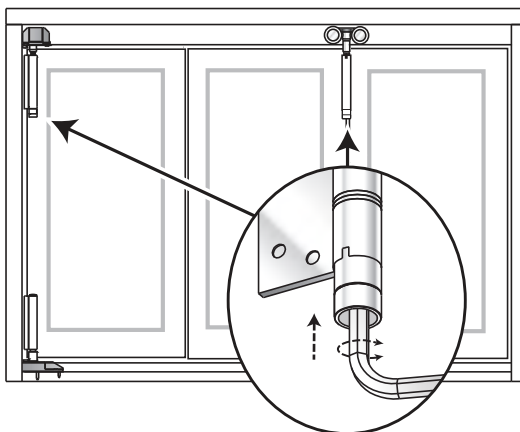

30 Adjust the top and bottom pivots to move the doors left or right.

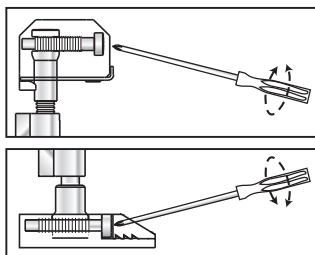

Final adjustment, correct spacing

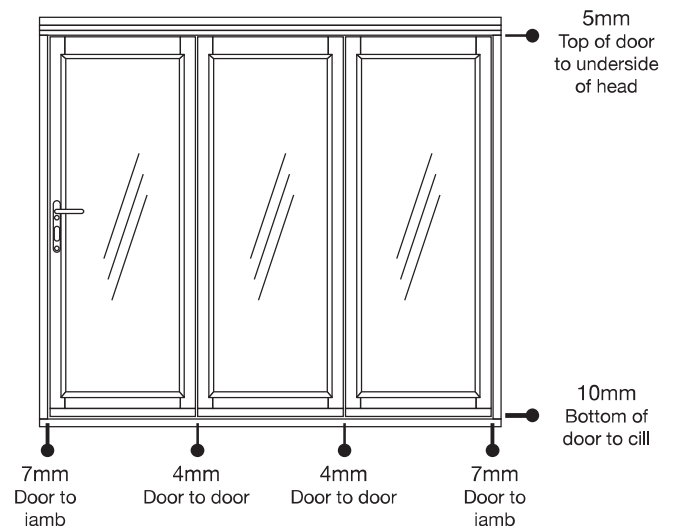

Fitting the lock and handle

31 Fit lock keeps into frame jamb next to door 3 using the pre-cut positions and using the M4 x 40mm Pozi screws (K).

Note. The centre keep has a long latch plate. For the most professional look, fit the latch plate into the frame by cutting and machining. If you do not want to cut the frame, fit the centre latch plate using the plastic spacers as shown in fig.A

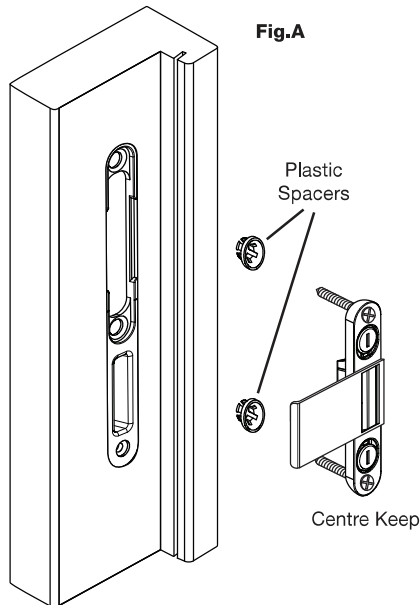
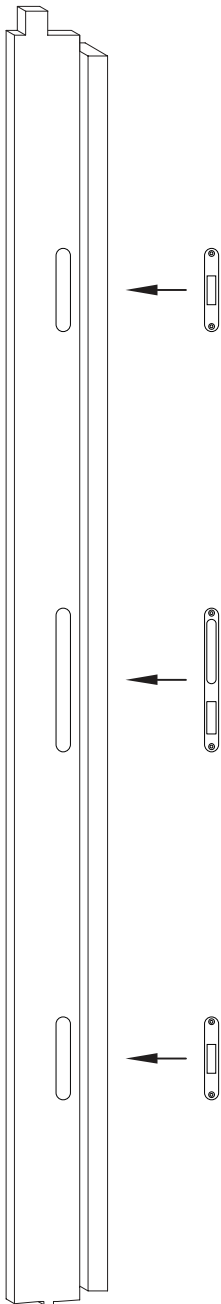

32 Fit blank keeps into frame jamb next to door 1 pivot door using the pre-cut positions and using the M4 x 40mm Pozi screws (K).

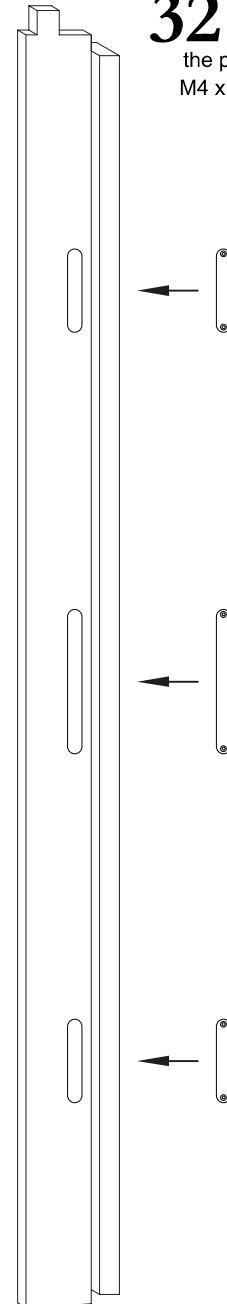

Fitting the lock and handle *continued*

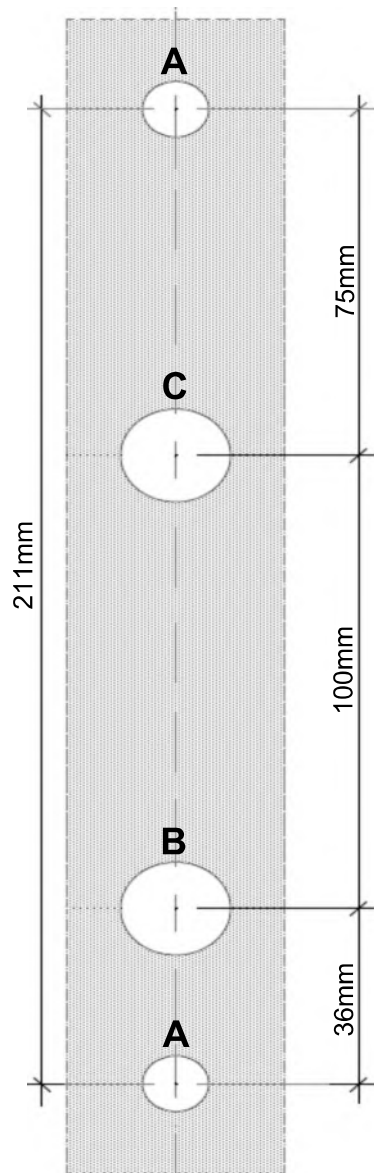

Handle & Lock Preparation

33a Carefully measure and mark out the centre points for both the 2 x Handle Screw Holes (A) and the 1 x Key Hole (B) on both faces of the door.

Your Spindle Hole (C) will be pre-machined.

Drill the 2 x Handle Screw Hole locations (A) using the 12mm flat wood bit, and drill the 1 x Key Hole Location (B) using the 22mm flat wood bit provided.

IMPORTANT: Ensure you enter into the door from both faces. Do not drill all the way through the door from one side and do not exit through the face of the door.

33b Fit the lock into door 3 and secure with the M4 x 40mm Pozi screws provided (K). (The key hole is always at the bottom)

34 Insert the spindle through the lock and fix both handles using the M5 x 65mm screws provided (M).

To lock the door, lift the handle upwards until the lock is fully engaged, then turn the key.

The latch should be set for right opening. For left opening remove the 2 latch screws and reverse.

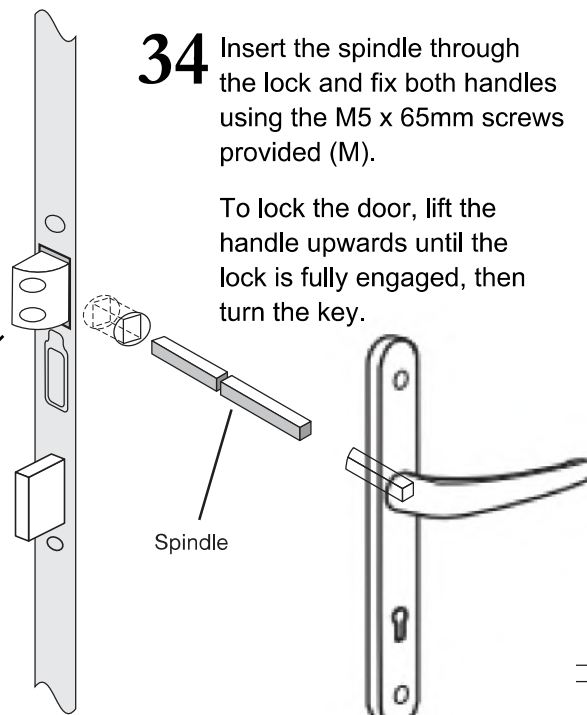
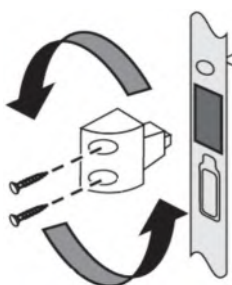

Spindle

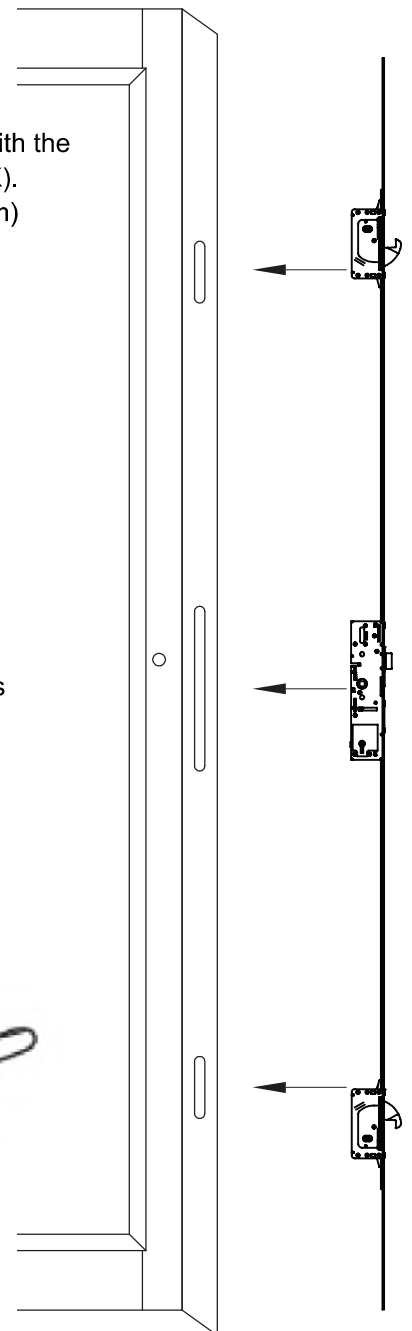

Fitting the catches to the doors

OPTIONAL EXTRAS

35 Fit the Door Stop and magnetic catches in the positions shown using the fixings provided.

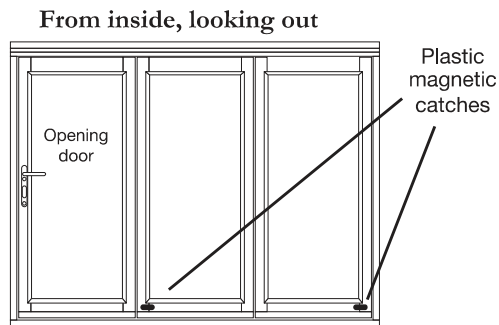
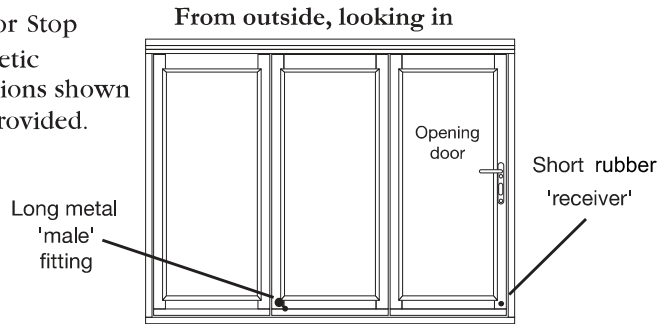

Operation of bifold doors

When closing the door set, first close doors 1 and 2, securing them with the dropbolts. Then close and lock door 3.

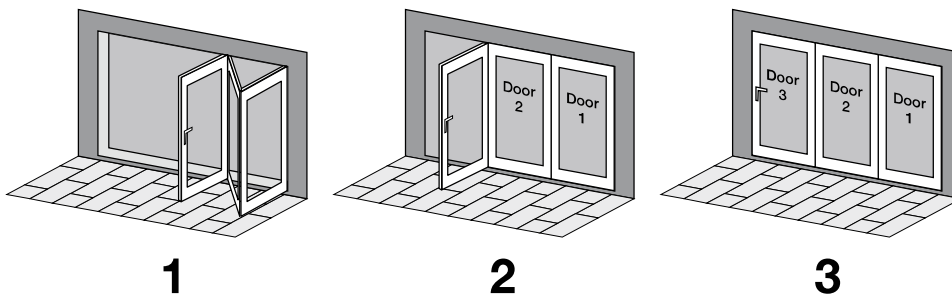



Macclesfield, Cheshire SK10 2BN

DECLARATION OF CONFORMANCE

DoC N°: JCI/FSD54S

Product Type:	54 Range - Timber Folding Sliding Door
Intended Use:	For use in domestic and commercial premises Not intended for use on escape route
Declared System of Assessment Performance:	3
Provisions to which the Product Conforms:	Annex ZA of EN 14351-1:2006+A2:2016
Reference to Supporting Product Certification and/or Test Reports <i>(supportive of compliance):</i>	Build Check Ltd - Weather Tightness Report W5089-1 Build Check Ltd - Thermal Performance Report CU21182-1 Rev1

Declared Performance:

Essential Characteristics

	Performance
Resistance to Wind Load:	Class A2 (800Pa)
Watertightness:	Class 2A (50Pa)
Dangerous Substance:	No emissions of dangerous substances emitted
Load Bearing Capacity of Safety Device:	Npd
Acoustic Performance	Npd
Thermal Transmittance:	1.4w/(m ² K)
Radiation Properties:	Npd
Air Permeability:	Class 4 (600Pa)

This declaration of performance is issued under the sole responsibility of JCI Limited.

Signed for and on behalf of the Company by

Name of Representative: John Collins

Job Title: Managing Director

Representative Signature:

Date of Issue: 12th May 2015

Product CE Marking Detail:

