

VUFOLD®

The difference is in the detail



HOMEOWNER *Manual*

How to get the most from
your purchase



T: 01625 442 899 | E: AFTERCARE@VUFOLD.CO.UK | W: WWW.VUFOLD.CO.UK

Introduction

Thank you for making a wise decision and choosing to buy a Vufold product. This Homeowners' Manual is designed to help you get the best from your new purchase. It has important information and advice for you, from delivery, handling, and storage to installation itself and caring for your products with regular cleaning and maintenance.

It also sets out the guarantees that will protect you when using our product(s) in your home. Many guarantees and warranties offered to customers are complicated, full of legal jargon and 'get out clauses' which are designed to confuse people. We have made ours as simple and straightforward as possible. We hope you find this refreshing and a different approach from the team at Vufold.

Contents

<u>The Vufold Guarantee</u>	1
<u>Delivery, Handling and Storage</u>	3
<u>Cancellations and Returns Information</u>	5
<u>Installation Information</u>	6
<u>External Wooden Bifold and French Door sets – Elite and Master ranges</u>	7
<u>External Aluminium Bifold and French Door sets – Supreme, Status and Heritage ranges</u>	13
<u>Composite Bifold Door sets – Ultra range</u>	16
<u>Wooden Front Doors – Oslo, Malmo, Stockholm, and Bergen ranges</u>	24
<u>Composite Front Doors – Traditional and Contemporary ranges</u>	28
<u>Aluminium Front Doors – Signature and Designer ranges</u>	32
<u>Roof Glazing – Roof Light and Roof Lantern ranges</u>	35
<u>Aluminium Windows – Casement, Flush Casement, Urban and Tilt and Turn ranges</u>	37
<u>UPVC Windows – Casement and Flush Casement ranges</u>	40
<u>Internal Wooden Bifold Door sets – Finesse, Urban and Edge ranges</u>	42
<u>Internal Fold Flat Door sets – Inspire ranges</u>	46
<u>Internal Wooden French Door sets – Finesse and Urban ranges</u>	50
<u>Internal Aluminium Doors – Aluspace ranges</u>	54
<u>Blinds – Face Mounted Micro-Pleat and Integral Slatted ranges</u>	56
<u>Making a Claim</u>	58
<u>Contact Us</u>	59

The Vufold Guarantee

Vufold offer 50% longer guarantee duration periods over its closest competitors, so you can enjoy peace of mind when you purchase from Vufold - incredible quality means you don't have to worry about expensive repairs in the future.

All Vufold products are guaranteed against the occurrence of manufacturing faults. The guarantee takes effect at the time the goods are delivered.

This guarantee covers the original purchaser only and proof of the date of purchase is required to validate it. This guarantee is non-transferable and is only valid while the purchaser remains in occupation of the installation address.

If you have not purchased a Vufold product directly from us and therefore have not accepted our [terms and conditions](#) of sale, then you will not be able to make a claim under the guarantee.

The guarantee is conditional upon complying with the Vufold instructions and recommendations for delivery, handling and storage, cancellations and returns, installation, and care and maintenance as set out in this

Homeowner's Manual. Failure to comply with the instructions and recommendations will invalidate this guarantee.

All components will be free of manufacturing defects when they arrive at your home. No manufacturing defect will appear during the period of this guarantee, subject to regular maintenance and cleaning by you on site.



Damage, including accidental, handling, storage, and general wear and tear are not classed as manufacturing defects and are therefore not covered under this guarantee.

Please ensure you have read and fully understood the assembly instructions provided before commencing installation.

External components can be affected by the weather. The location and environment will have a significant effect on the durability of the materials.

Coastal and marine locations within a 5-mile radius of the sea are considered to be more severe environments due to the higher levels of salt content, moisture, and chemicals in the air. Factors to consider are high winds coming in land from the sea, with no shelter from hills or other buildings, corrosive effects from the saline rich wind driven rain and higher levels of UV.

Other factors for more aggressive environments to consider are high levels of pollution in industrial environments and anywhere chemicals can pollute the air such as a swimming pool. Poorly ventilated rooms, moisture rich environments and severe temperature levels can all impact the durability of your chosen material and operation.

Deterioration to any components, including but not limited to the material itself, surface area finishes and failure in mechanical operation that may be caused by the environment and location the product is installed in, particularly areas with higher levels of salt content, are not classed as a manufacturing defect and are therefore not covered under the guarantee.

IMPORTANT: As the purchaser, it is your responsibility to ensure the product(s) are suitable for the location and / or environment they will be installed in, regardless of the delivery address provided to us on the order.

Due to updated requirements of building regulations and home insulating aids to create warmer rooms; this often reduces the amount of ventilation and air temperature changes. The result is the formation of condensation on the coldest surface within a room as the moisture in the air produced by normal living activities is unable to escape. The formation of external condensation is a natural phenomenon and gives a good indication that your energy efficient windows, doors and / or glazing are preventing heat loss from the property.

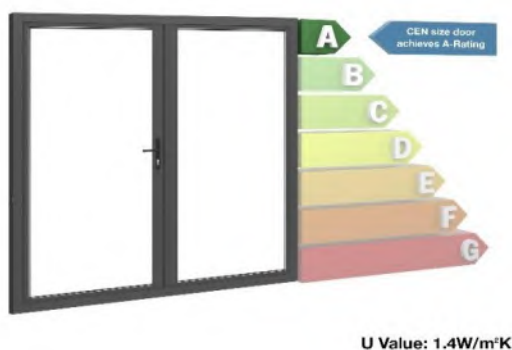

Condensation forming on the inside or outside of the window, door, glass, or frame components is not classed as a manufacturing defect.

Condensation should not form inside the cavity of the sealed glazing unit during its guarantee period.

All single, double, and triple glazed units are guaranteed against the occurrence of manufacturing faults and supplied in accordance with GGF (Glass and Glazing Federation) standards.

We will not accept any claims for defective glass that is not set out in the advice and guidance of the GGF.

GGF Guides:

[Condensation](#)

[Quality of Vision Guide](#)

[Low Emissivity Glass](#)

By installing your product(s), you are accepting the product in the condition that it has arrived to you in. We will not accept any claims under this guarantee for any anomaly reported after installation that would have been apparent following inspection of the goods, including but not limited to all types of damage, scratches, and imperfections.

This guarantee does not exclude any statutory rights of the purchaser.



Please see individual product range pages for further information.

Delivery, Handling and Storage

Vufold only uses reputable 3rd party companies for the delivery of our products. Whilst we have very few delivery issues, from time-to-time things can go wrong. The below information is to protect you in the event of any unforeseen circumstances, so it is important our guidance is followed.



We do not recommend booking your installation until you have received your order, and it has been fully checked for any missing or damaged parts. We will not accept liability for any costs incurred due to any delays to your installation. Please ensure you have had this discussion with the relevant person(s), including any other trades prior to booking in the installation.

Before your delivery arrives, it is important that you have made the relevant arrangements to

ensure somebody is available to check and sign for the goods on the agreed delivery date. We recommend this is carried out by you / the original purchaser. If you are giving this responsibility to another person, it is important you advise them to follow the correct procedure when accepting the goods as set out below.

Delivery

When your delivery arrives and before you accept the goods into your property, please check the itemised paperwork provided by the delivery company matches the number of items being delivered. Please then check all items to confirm there has been no obvious damage to the packaging and goods by fully inspecting all faces, edges, and corners. Please also ensure it is your name and post code printed on the labels on each of the individual items.



If there are any discrepancies in the quantities of doors / packs received, or packaging damage is evident, and / or there is an incorrect label, please contact our Customer Service department immediately whilst the delivery company is still there. We will then advise you on the best course of action.

If you have taken delivery outside of our normal working hours or if it is not possible to contact our Customer Service department, and there are any missing items, and / or damage to the packaging, please clearly record on the delivery company's paperwork what is missing and / or damaged. Accept delivery of your order and contact our Customer Service department within 72 hours of receipt of the goods.

IMPORTANT: You should never sign the delivery documents as "Unchecked." Any shortages and / or damages must be noted on the delivery paperwork, no exceptions. We cannot accept any claims for missing items and / or any damaged items if it has not been recorded on the delivery paperwork, regardless of who you have arranged to accept your order.

Some products and sizes are only available on a kerb-side delivery. Our processing team will contact you in advance to discuss the weights and dimensions of your individual order, so you can ensure sufficient people are on hand to safely offload these items.

For kerb-side delivery, upon arrival our driver will identify a suitable access point as close to the delivery address as possible, and you must collect your goods from the vehicle. Our driver is unable to assist with the offloading of your goods or assist with getting them into your home.

Loose glass can have sharp edges. It is recommended that protective gloves and glass lifters are used when carrying the units into the property.

If everything is satisfactory with the delivery, the items can then be carried into your room of choice and the delivery paperwork signed accordingly. You should then fully unpack the product(s) and check for manufacturing faults, defects, or missing parts within 72 hours of receiving delivery. You'll find a full list of the items you should have received in the assembly instructions included within the hardware pack. Please note there is no need to refuse delivery and or return the full set if a component is found to be defective or missing.



Please note, the carrier will not transport the goods up or down stairways or in lifts that are only designed to carry people.

IMPORTANT: We cannot accept claims for any damages, scratched glass, scratched aluminium or missing items after 72 hours following delivery or after installation has begun.

Handling and storage

The products are heavy and can weigh approximately 30kg to 60kg each. They will therefore need two people to carry them.

When storing items before installation, once all items have been checked, they should be re-packed and kept in their original packaging, handled with care, and stored in a dry, ventilated building. They should be stored flat on a level surface - not on edge or on end.

For any items supplied unglazed; Loose glass units should never be placed directly onto hard floors such as concrete, but should be placed on cardboard, sheeting, or wooden batons, on edge rather than flat. The glass should be stored on its edge and at a 3 – 6 degree angle. Glass should not be stored horizontally or on top of each other and should not come into contact with anything harder than itself.

If you are transporting the goods to an alternative address other than provided on your original order, it is important you fully inspect the goods for any damages or missing items before arranging forwarding transportation. We cannot accept any claims for damages or missing items should the goods have been forwarded on to an alternative location.

IMPORTANT: It is your responsibility to ensure the correct protective and lifting equipment is used when handling the goods. Vufold will not be held liable for any accidents or personal injuries sustained during the delivery, handling and storage process.

Cancellations and Returns

We understand that due to unforeseen circumstances, orders may need to be cancelled. Under **The Consumer Contracts (Information, Cancellation and Additional Charges) Regulations 2013**, from receipt of your order, you have up to 14 days in which to notify us in writing of your cancellation and then up to a further 14 days to return the goods to us without giving a reason.

Your right to cancel and cancellation period will expire after 14 days from the day on which you acquire or a third party other than the carrier and indicated by you, acquires physical possession of the product(s).

Before arranging the return of your order, please read our full Cancellation and Returns Policy as set out below, and then contact a member of the Customer Service team who will assist you further.

If you cancel your order/contract with us, we request that all product(s) should not be unpacked on arrival where it is not necessary to assess or handle the products. If you do unpack, it is your responsibility and in your own interest to ensure adequate packing of the product(s) for them to be returned to our warehouse.

It is important that the items are returned to us in the original packaging and in the same condition they were delivered to you in.

Any damaged or missing items that have not been previously reported and agreed by Vufold, will be deducted from your refund.

For any opened doors / packs, the item(s) are to be repacked using clear tape only, do not use any coloured tape or any other types of packaging other than originally supplied.

If you have ordered an incorrect product, size, or colour, or wish to make any amendments to an existing order, we do not offer an exchange service. This cancellation and returns process will need to be followed and a new order will need to be placed for the correct product.



If you ordered during a sale or promotional period, or received any form of discount, this will not automatically be applied to any new orders placed, unless otherwise agreed by a Vufold representative.

IMPORTANT: We cannot accept cancellation and returns for any made to order and customizable products from any of our product ranges, including but not limited to; windows, internal and external bifold doors (non-express), French and sliding door sets, roof glazing, composite doors, aluminium front doors, and blinds.

Please visit our web site for the full [Cancellations and returns procedure](#)

Installation Information

We quite often see products installed at too early a stage in the project, with many trades still accessing the room(s), with various works still due to be carried out, and leaving your newly installed product(s) exposed and in a vulnerable position. It is recommended that your new purchase is installed as late into the project as possible.

Some components will not perform well in new rooms that are full of moisture, especially when combined with central heating or other heating systems. Where possible, ensure that all wet trades like plastering, painting, floor installation and finishing, are completed and the room is fully dried out before installation.

We do recognise that this is not always practical, especially with extensions or new build installations. Often, the windows / door set is installed before these jobs are completed or dried out. Then it can act as a barrier to the weather outside – and make the home secure – so that work can carry on inside the room. In this scenario it is important to make sure the product has been fully inspected and then adequate protection is applied to all frame components, doors, and glass. Extra protection should be applied to the bottom cill / threshold

as this is the most exposed area and prone to damages.

All Vufold products have been designed to be installed by the relevant experienced trades person(s) or for most of our products, by competent DIYers. Do not commence installation unless you or your chosen installers fully understand the task at hand and are confident you / they have the required skill set to complete the works.



It is important that all products are installed as per the instructions provided with your order.

Vufold will not accept any responsibility for products which have been cut down or machined or otherwise hung from the original, standard product specification we supplied to you unless advised to do so in the relevant

fitting instructions supplied with your purchase.

Before commencing the installation, double check the opening is the correct size and the items you've received are to the correct specification including size, handing, colour, and glass before discarding any packaging. This includes any components that may be supplied fitted or loose. Check the items are free from damage. If replacing an existing door / window, we advise not to remove this until all checks have been completed.

The brickwork opening should be 10mm bigger in height and width than the assembled outer frame size. Please ensure that all dimensions are correct for installation before proceeding as the door set must be installed square and level into the opening.

Following completion of installation, all protective film, tape, and labels are to be removed immediately from the doors, frames, and all glass. We cannot accept any claims relating to adhesive marks / residue reported after installation.

External Wooden Bifold and French Door sets – Elite and Master ranges

All Vufold external wooden doors and frames, double glazed sealed units, and hardware components are guaranteed for a full 10 years against the occurrence of manufacturing faults, all subject to correct installation and regular maintenance and care in use as detailed below.



Door and frame components

All our timber components are manufactured using the latest technology to reduce warping or twisting - this is referred to in the trade as 'engineered construction'. This means we use finger jointed or laminated hardwood sections in the core and then they are over veneered.

This method has proven to be stronger and less likely to cause movement of the timber than using solid sections.

No two trees produce identical grains or colour of wood, and this adds to the beauty of a natural product. We therefore cannot guarantee that all door and frame components will look exactly the same in grain and colour. Veneers are natural products and prone to deterioration if not adequately protected with superior quality finish. If water penetrates the finish this may cause cracks to appear or splits. In heavy moisture areas or during heavy rain periods, this may cause oak to become darker in colour or have black marks.

Unfortunately, we cannot change the properties or performance of the timber components which are natural products. We cannot therefore accept claims for any variation in the components, or cracks or splits that may appear due to moisture going into the timber. What is more, warping of wood is not a defect if it is not more than ¼ inch (6mm) when it is in its installed position.

Protective Finish and maintenance

IMPORTANT: You would normally be expected to maintain the protective finish between 2 – 5 years depending on the weather and location. The finish on your Vufold door set must be checked every six months for deterioration,

and re-coated if necessary. The finish must be regularly maintained, to ensure moisture does not enter the timber during the life of the product.

Following installation; the door and frame components must be fully inspected for any surface area damages that may have compromised the protective coating, and re-sealed where necessary.

Elite Unfinished Oak Door sets

All unfinished oak door sets must be fully finished according to our guidelines BEFORE the door set is installed. Failure to do so will invalidate the guarantee. Please note that the use of steel wool or allowing steel or iron fragments to come into contact with the untreated oak timber or veneers may cause oxidation resulting in black staining.

We recommend finishing external unfinished oak door sets with a medium or high build microporous wood coating system. This will usually consist of one coat of base stain and two coats of topcoat, in a wood or paint colour of your choice, to **ALL** faces and edges of the doors and frame components to ensure the product is fully sealed, including the tops and bottom edges of the doors. You can purchase the Vufold-Sigma High Build microporous Wood Coating system to finish your Vufold set

from Vufold or alternatively use a proprietary brand such as Dulux, Sadolin or Sikksens.

We do not recommend finishing with oil, wax, quick drying products such as Ronseal or any finish other than a medium to high build microporous wood finishing system. Please note, the clearer the finish the more regular maintenance will be required.



Elite Pre-Finished Oak Door sets

Pre-finished oak door sets have been factory finished using a high build microporous wood coating system and are ready for installation. This finish offers good UV protection.

All pre-finished Vufold door sets must be well maintained and re-coated as and when necessary, before the coating breaks down. Moisture must not be allowed to penetrate the timber. The length of time between re-coating depends greatly on exposure to weather and the direction the bi-fold doors face. The

coating will last longer in a sheltered or north facing site. However, if the site is south facing, or in a heavy weather exposure area, the finish will need maintaining more frequently.

Vufold now offer maintenance kits, under the Vufold Sigma brand, which contains everything you need to maintain your pre-finished oak, bi-fold door or French door set. The regular use of Vufold-Sigma Wood care milk 3 to 4 times a year will prolong the period before re-coating is necessary.

We do not recommend re-finishing with oil, wax, quick drying products such as Ronseal or any finish other than a medium to high microporous wood finishing system.

Master Pre-Finished White and Grey Hardwood Door sets

The white and grey external door sets have been pre-finished with a high build microporous opaque Satin wood finish. This finish offers good UV protection.



All pre-finished Vufold door sets must be well maintained and re-coated as and when necessary, before the coating breaks down. Moisture must not be allowed to penetrate the timber. The length of time between re-coating depends greatly on exposure to weather and the direction the bi-fold doors face. The coating will last longer in a sheltered or north facing site. However, if the site is south facing, or in a heavy weather exposure area, the finish will need maintaining more frequently.

Vufold now offer maintenance kits, under the Vufold Sigma brand, which contains everything you need to maintain your pre-finished white or grey, bi-fold door or French door set. The regular use of Vufold-sigma Wood care milk 3 to 4 times a year will prolong the period before re-coating is necessary.

We do not recommend re-finishing with any finish other than a medium to high build microporous opaque wood finish finishing system. The RAL (colour match) paint code for the white finish is 9016 Traffic White and the grey finish is RAL 7016 Anthracite grey.

Installation

Our ready-to-assemble external wooden doors are supplied with all the essential items and virtually everything pre-machined. This design allows for simple on-site assembly by a

competent DIYer or experienced trades person(s).

Importantly, the outer frame head of our external bi-fold door sets needs to be securely fixed to the building lintel as the door sets are top hung. The frame needs to be installed perfectly square and level on all planes into the opening.

Please ensure you have read the installation instructions supplied with your door set. To make life even easier, we also have a 'How to Install a Wooden External bifold door' installation video available on our web site and on YouTube [How to Install a Wooden External bifold door - Vufold](#).

Double glazed sealed units

All glass is supplied to The GGF (glass and glazing federation) standards.

To reduce carbon emissions from the home and to keep heating and cooling bills down, the government has recommended that all manufacturers use special Low E thermal glass within the sealed unit to comply with Building Regulations Part L.

This glass is coated with a special substance to comply with the above and occasionally, and in certain light conditions, may produce transient visual effects, this can sometimes look like a

transparent film or haze, and make the glass appear cloudy. This is very infrequent and only affects a minority of door sets. But as a company, we do have to comply with the new regulations which are for the benefit of all, and this is not a defect.

Due to demands for better thermal efficiency, it is normal for condensation to form on the outside of the glazing units, to the exterior side of the property. This demonstrates that the glass is performing as it should by reducing the transfer of heat from the internal side of the property to the external side of the property, this is not a defect. For any condensation forming to the inside of the property, this is normally due to high levels of moisture in the air and / or insufficient ventilation in the room, the moisture is then forming on the cold surface. If condensation is forming inside the glazing unit (between the panes of glass) it is likely that the glazing seal has been compromised.

Tempered glass means it has been toughened to be up to five times stronger than normal glass. It is unusual to break such strong glass, but sharp objects hitting the glass at certain points can cause breakage. Tempered glass is also known as safety glass. This means that if it breaks it will shatter into smaller fragments which are less likely to cause injury, unlike non-

tempered glass which breaks into large, sharp fragments.

Glass must be regularly maintained and cleaned to stop the breakdown of the glass or seals. This can be done using a mild solution such as washing-up liquid diluted in water. Do not use abrasive cleaning solutions as this may cause scratching.

Visual distortions caused by reflections in toughened glazing units are a natural phenomenon and not a fault.

Toughened, or coated glass is acceptable if bubbles or blisters, fine scratches no more than 2.5cm long and / or minute particles are neither obtrusive nor bunched. The glass used in sealed units is a processed glass therefore certain blemishes are unavoidable.

Hardware components

The exterior hardware in your Vufold bi-fold door set can deteriorate from everyday use, and also because of the weather and the local environment. That's why regular maintenance of your door hardware is even more important if you live in severe environments like coastal marine areas and some industrial locations. Even stainless-steel products require maintenance to prevent deterioration in these environments.

We require that the below minimum maintenance is carried out as often as necessary to prevent deterioration. As a guideline, we recommend that this maintenance is done every three months if you live in a marine environment, or every six months if you live in a more general location otherwise your guarantee will not be valid.

Tracks and bearings

Once your installation has been completed, and before fully operating your door set, please carefully remove any debris / swarf from the top and bottom tracks to ensure nothing comes into contact with any moving components.

After cleaning the tracks, using a microfibre cloth, apply a small amount of lubricant such as silicone spray to the inner lip of each side of the track. Make sure that the wheels pass through the lubricant and that it spreads evenly along the track.

Extra lubricant can be added around the bearings. Adding lubricant in this way reduces wear, improves smoothness, and gives additional protection against corrosion of track and bearings. In addition, remove all surface contamination by wiping all visible track surfaces with a soft, damp cloth and mild detergent, then wipe with a clean cloth. In severe environments, apply a thin film of

corrosive preventative such as silicone spray, and wipe with a clean microfibre cloth.

Stainless-steel bearings are made from hardening grade stainless-steel, and although this material performs much better than plated steel, it can corrode unless it is maintained as shown above.



Hinges, pivots and drop (slide) bolts

Using a microfibre cloth, wipe down the visible surfaces with warm soapy water and then rinse off by wiping with a clean, damp cloth. Applying a thin film of light machine oil or silicone spray, wiping with a dry cloth to remove any excess, will help to maintain the original lustre of the metal finish. Be careful not to get these liquids on the timber as this can cause staining.

The sliding pin and lock cylinder on the drop bolts should be maintained using silicone spray by directing the nozzle into the applicable

areas. Always hold a cloth directly under the nozzle to prevent any over spray or liquid running onto the timber.

Multi-point door locks and handles

The multi-point door lock is operated by lifting the handle and turning the key. The lock is secured by top and bottom hook bolts and a central deadbolt engaging with the lock keeps. The lock should operate just as smooth with the access door in the open position as what it does when it is fully closed.

It is important that if you feel any resistance when lifting the handle, you do not continue to operate the doors as this may eventually cause the lock to fail and will invalidate your guarantee. All moving parts should be lubricated using a silicone spray.

The handles should be regularly cleaned with a soft damp microfibre cloth to remove any dust or grime taking care not to scratch the surface.

If you experience problems with locking or unlocking the doors, first eliminate actual lock problems by opening the access door and pulling the handle upwards and then turning the key. If this can be done, the lock is operating normally, and the problem is likely to be due to incorrect door alignment / adjustment.

Door operational adjustments

When your doors are first installed, they may require some fine tuning to achieve a smooth operation. All our wooden external door sets are supplied with easy to adjust hinges. From time to time, due to changes in the seasons or because of wear and tear in use, or if the lock is difficult to operate, it may also be necessary to carry out some hinge adjustments.

Bifold Door up / down (height) adjustment

If the doors are catching or scraping the cill and you have checked the frame head is securely fixed to the lintel, then the doors need to be adjusted up higher. Identify the pivots and intermediate carriers, for Allen key adjustment method, (see FIG A) insert the Allen key provided and then turn clockwise to raise the doors and anti-clockwise to lower the doors.

FIG A: ALLEN KEY ADJUSTMENT METHOD

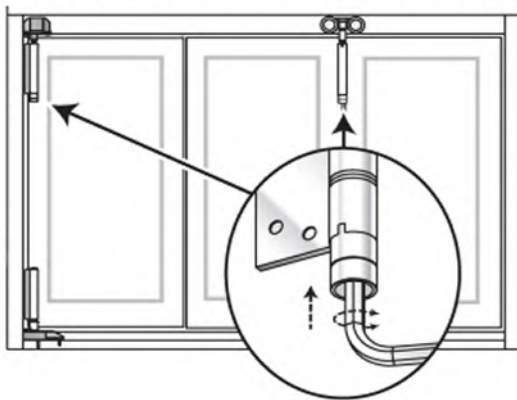

For screwdriver adjustment method (see FIG B), pull down the safety clip and use a screwdriver to adjust the doors up or down. Raise or lower the height of the doors by adjusting the top pivot and intermediate carrier.

FIG B: SCREWDRIVER ADJUSTMENT METHOD

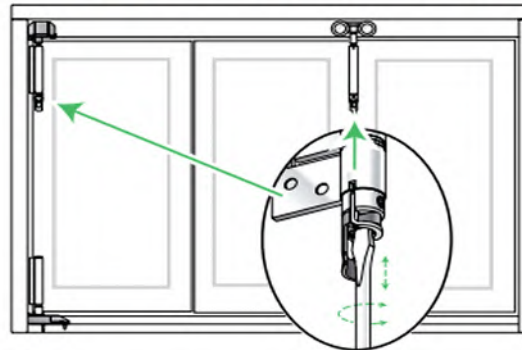

Bifold Door side to side (width) adjustment

With the doors in the fully open position, access the top and bottom pivot blocks which are located inside the corners of the top and bottom tracks. Using a long / extended Philips screwdriver, turn the screw clockwise or anticlockwise to move the doors left or right, as required (see FIG C).

FIG C

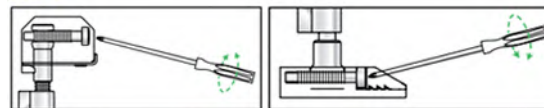

If you experience any difficulty operating your doors, including, opening, closing, sliding, and locking of your doors, do not continue to use your doors as this may cause further issues and damages.

French Door side to side (width) adjustment

To adjust the spacing in-between the doors and the outer frame, locate the top adjustment screw, insert the 4mm Allen key provided; turn clockwise to position the doors closer together or anticlockwise to position further apart. Adjust each hinge as required to achieve even spacing.

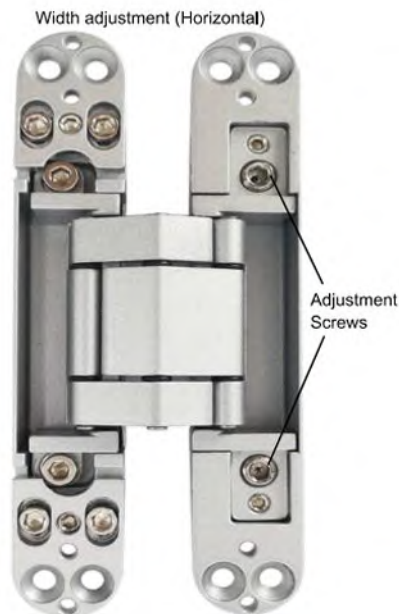

French Door in / out (depth) adjustment

To adjust the door to frame compression, locate the 2 clamping screws on both top and bottom hinges, insert the 4mm Allen key and turn anticlockwise to slightly loosen them off. Manually align the door into the desired compression and then turn all the clamping screws clockwise to re-tighten. Repeat the process on the adjacent door if required.

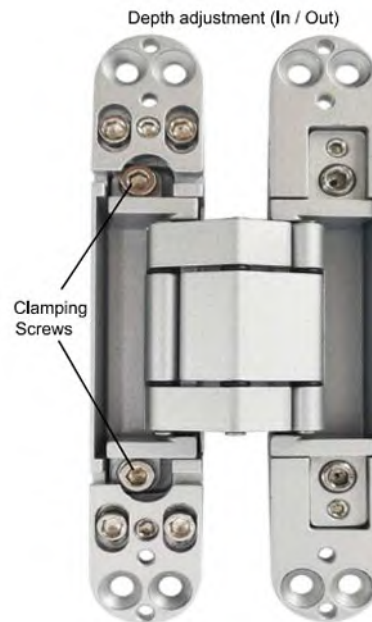

French Door up / down (height) adjustment

If you need to raise or lower the door(s), place air wedges or supports under the doors to take the weight off the hinges. Locate the 4 clamping screws and 2 adjustment screws on both top and bottom hinges, insert the 4mm Allen key into the clamping screws and turn anticlockwise to loosen them. Insert the 3mm Allen key provided into the adjustment screws and turn anticlockwise to loosen them. Manually raise or lower the doors by inflating or deflating the air wedges or adding or reducing the supports. Once the doors are in the desired position; retighten all clamping and adjustment screws.

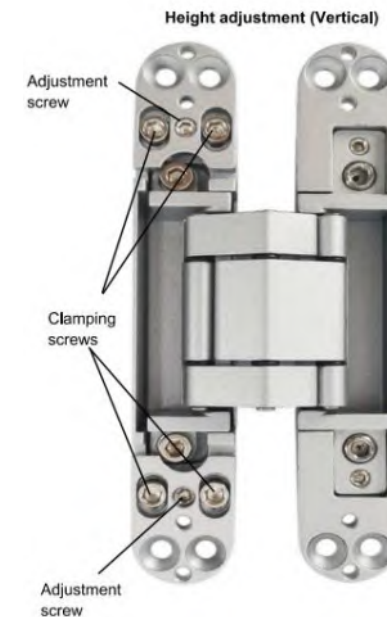

External Aluminium Bifold and French Door sets – Supreme, Status and Heritage ranges

All Vufold external aluminium doors and frames, powder coating finish, double and triple glazed sealed units, and hardware components are guaranteed for a full 15 years against the occurrence of manufacturing faults, all subject to correct installation, regular maintenance and care in use as detailed below.

Powder Coating finish and maintenance

All our Aluminium external Bifold and French door sets are supplied fully powder coated in a satin finish providing a high quality and durable finish, unless otherwise specified.

Our standard range of colours are Anthracite grey – RAL 7016, Hipca white – RAL 9910 (Status range only) White Gloss (Supreme range only), and Jet black – RAL 9005. If you have selected an alternative custom colour option and require the colour and RAL code, please contact a Vufold team member and they will provide this for you.

To maintain the external aluminium powder-coated finish, wash regularly with soapy water and then dry off with a soft lint-free cloth. As a

minimum, the external surfaces must be washed at least every three months, and monthly if within five miles of the sea or in an industrial area. Our general recommendation would be to wash the external aluminium every time you clean your windows, which should normally be more regularly than the minimum requirement.

The powder coating is not guaranteed unless the doors are installed at least 800 metres away from the sea.

We cannot accept any claims for damages, including scratches to the powder coating and aluminium reported 72 hours following delivery and / or after installation has commenced.

Installation

Our ready-to-assemble aluminium doors are supplied with all the essential items, most hardware factory fitted and everything pre-machined. This design allows for simple on-site assembly by a component DIYer or experienced trades person(s).

The outer frame needs to be securely fixed into the opening perfectly square and level on all planes. The aluminium bifold doors are bottom hung / rolling, the weight of the doors is supported via the bottom carrier and threshold.

IMPORTANT: The threshold must be sufficiently packed to ensure there are no dips or rises along the full length of the bottom track, and even more importantly, where the bottom carrier rests when closed. When fixing the frame head ensure there is no bowing.

Please ensure you have read the installation instructions supplied with your door set. To make life even easier, we also have a 'How to Install an Aluminium External bifold door' installation video available on our web site and on YouTube [How to Install an Aluminium External Bifold Door - Vufold](#) (Status range only).

Double and Triple glazed sealed units

All glass is supplied to The GGF (glass and glazing federation) standards.

To reduce carbon emissions from the home and to keep heating and cooling bills down, the government has recommended that all manufacturers use special Low E thermal glass within the sealed unit to comply with Building Regulations Part L.

This glass is coated with a special substance to comply with the above and occasionally, and in certain light conditions may produce transient visual effects, this can sometimes look like a transparent film or haze, and make the glass appear cloudy. This is very infrequent and only

affects a minority of door sets. But as a company, we do have to comply with the new regulations which are for the benefit of all, and this is not a defect.

Due to demands for better thermal efficiency, it is normal for condensation to form on the outside of the glazing units, to the exterior side of the property. This demonstrates that the glass is performing as it should by reducing the transfer of heat from the internal side of the property to the external side of the property, this is not a defect. For any condensation forming to the inside of the property, this is normally due to high levels of moisture in the air and / or insufficient ventilation in the room, the moisture is then forming on the cold surface. If condensation is forming inside the glazing unit (between the panes of glass) it is likely that the glazing seal has been compromised.

Tempered glass means it has been toughened to be up to five times stronger than normal glass. It is unusual to break such strong glass, but sharp objects hitting the glass at certain points can cause breakage. Tempered glass is also known as safety glass. This means that if it breaks it will shatter into smaller fragments which are less likely to cause injury, unlike non-tempered glass which breaks into large, sharp fragments.

Laminated glass is also classed as safety glass and comprises of multiple layers of glass sandwiched together. Due to its high strength, this prevents the glass from breaking into large pieces. If the glass breaks, it will produce a 'spider web' effect similar to what is commonly seen in shattered car windscreens. Laminated glass will also increase the sound rating insulation.

Glass must be regularly maintained and cleaned to stop break down of the glass or seals. This can be done using a mild solution such as washing-up liquid diluted in water. Do not use abrasive cleaning solutions as this may cause scratching.

Visual distortions caused by reflections in toughened glazing units are a natural phenomenon and not a fault.

Laminated, toughened, or coated glass is acceptable if bubbles or blisters, fine scratches no more than 2.5cm long and / or minute particles are neither obtrusive nor bunched. The glass used in sealed units is a processed glass therefore certain blemishes are unavoidable. More blemishes may be visible in laminated glass due to the layered construction.

Hardware components

The exterior hardware in your Vufold bi-fold door set can deteriorate from everyday use, and also because of the weather and the local environment. That's why regular maintenance of your door hardware is even more important if you live in severe environments like coastal / marine areas and some industrial locations.

We require that the below minimum maintenance is carried out as often as necessary to prevent deterioration. As a guideline, we recommend that this maintenance is done every three months if you live in a marine environment, or every six months if you live in a more general location otherwise your guarantee will not be valid.



Tracks and bearings

Once your installation has been completed, and before fully operating your door set, please carefully remove any debris / swarf from the top and bottom tracks to ensure nothing comes into contact with any moving components.

After cleaning the tracks, using a microfibre cloth, apply a small amount of lubricant such as silicone spray to the inner lip of each side of the track. Make sure that the wheels pass through the lubricant and that it spreads evenly along the track.

Extra lubricant can be added around the bearings. Adding lubricant in this way reduces wear, improves smoothness, and gives additional protection against corrosion of track and bearings. In addition, remove all surface contamination by wiping all visible track surfaces with a soft, damp cloth and mild detergent, then wipe with a clean cloth. In severe environments, apply a thin film of corrosive preventative, such as silicone spray, and wipe with a clean microfibre cloth.

Hinges

Using a microfibre cloth, wipe down the visible surfaces with warm soapy water and then rinse off by wiping with a clean, damp cloth. Applying a thin film of light machine oil or silicone spray, wiping with a dry cloth to

remove any excess, will help to maintain the original lustre of the metal finish. Be careful not to get these liquids on the aluminium as this may affect the powder coating.

Multi-point door locks and handles

The multi-point door lock is operated by lifting the handle and turning the key. The lock is secured by hook bolts and a central deadbolt engaging with the lock keeps. The lock should operate just as smooth with the access door in the open position as what it does when it is fully closed.

It is important that if you feel any resistance when lifting the handle, you do not continue to operate the doors as this may eventually cause the lock to fail and will invalidate your guarantee.

All moving parts should be lubricated using a silicone spray.

The handles should be regularly cleaned with a soft damp microfibre cloth to remove any dust or grime taking care not to scratch the surface.

If you experience problems with locking or unlocking the doors, first eliminate actual lock problems by opening the access door and pulling the handle upwards and then turning the key. If this can be done, the lock is operating normally, and the problem is likely to

be due to incorrect door alignment / adjustment.

Door operation

All our aluminium Bifold and French door sets have been pre-assembled in our factory. They are installed into a steel framed testing rig where they are glazed / toe and healed and then fully operated, including checking the doors lock and unlock smoothly. The door sets are then part dismantled, packaged up ready for dispatch and simple onsite assembly.

When operating your doors, it is vital that you close the folding sections of your door set first, using the hinge / d-pull handle only and then turn the swivel handle to secure the folding sections in place, closing the access door last. Never pull or push the doors along the track using the lead / daily access door as this will affect the balance of the doors and may damage the hardware.

If you experience any difficulty operating your doors, including, opening, closing, sliding, and locking of your doors, do not continue to use your doors as this may cause further issues and damages. Please contact a member of the Customer Service team so we can assist you further.

External Composite Bifold Door sets – Ultra range

All Vufold external composite Bifold doors and frames, triple glazed sealed units, and hardware components are guaranteed for a full 10 years against the occurrence of manufacturing faults, the external powder coating finish is guaranteed for 15 years, all subject to correct installation and regular maintenance and care in use as detailed below.



Door and frame components

All our timber components are manufactured using the latest technology to reduce warping or twisting - this is referred to in the trade as 'engineered construction'. This means we use finger jointed or laminated hardwood sections in the core and then they are over veneered.

This method has proven to be stronger and less likely to cause movement of the timber than using solid sections. Veneers are natural products and prone to deterioration if not adequately protected with superior quality finish. If water penetrates the finish this may cause cracks to appear or splits. In heavy moisture areas or during heavy rain periods, this may cause oak to become darker in colour or have black marks.

No two trees produce identical grains or colour of wood, and this adds to the beauty of a natural product. We therefore cannot guarantee that all door and frame components will look exactly the same in grain and colour. What is more, warping of wood is not a defect if it is not more than ¼ inch (6mm) when it is in its installed position.

Protective finish and maintenance

Aluminium powder coating

All our composite Ultra external Bifold sets are supplied externally powder coated in a satin finish providing a high quality and durable finish.

Our standard range of external powder coated colours are Anthracite grey – RAL 7016 and Traffic white – RAL 9016.

To maintain the external aluminium powder-coated finish, wash regularly with soapy water

and then dry off with a soft lint-free cloth. As a minimum, the external surfaces must be washed at least every three months, and monthly if within five miles of the sea or in an industrial area.

Our general recommendation would be to wash the external aluminium every time you clean your windows, which should normally be more regularly than the minimum requirement.

The powder coating is not guaranteed unless the doors are installed at least 800 metres away from the sea.

We cannot accept any claims for damages, including scratches to the powder coating and aluminium reported 72 hours following delivery, and / or after installation has commenced.

Oak Polyurethane (PU) finish

The Oak has been pre-finished with a tinted polyurethane satin finish, providing a resilient natural look and is ready for installation.

All pre-finished Vufold door sets must be well maintained and re-coated as and when necessary, before the coating breaks down. Moisture must not be allowed to penetrate the timber. The length of time between re-coating depends greatly on exposure to weather and

the direction the bi-fold doors face. The coating will last longer in a sheltered or north facing site. However, if the site is south facing, or in a heavy weather exposure area, the finish will need maintaining more frequently.

We recommend all oak faces and edges of the doors and frames are recoated using a polyurethane finish, ideally with UV and weather protection, from a proprietary brand.

We do not recommend re-finishing with oil, wax, quick drying products such as Ronseal or any finish other than a medium to high microporous wood finishing system.

IMPORTANT: The PU finish on your Vufold door set must be checked every six months for deterioration and re-coated if necessary. This will maintain the decorative finish and ensure that no moisture enters the timber of the doors and frames during the life of the product.

Areas exposed to UV rays and high traffic areas such as the bottom cill may require more regular maintenance depending on how often you use the doors and their environment. This will maintain the decorative finish and ensure that no moisture enters the timber of the doors and frame during the life of the product.

Unfortunately, we cannot change the properties or performance of the timber

components which are natural products. We therefore cannot accept claims for any variation in the components, or cracks or splits that may appear due to moisture going into the timber.

Installation

Our ready-to-assemble composite bifold doors are supplied with all the essential items and virtually everything pre-machined. This design allows for simple on-site assembly by a component DIY'er or experienced trades person(s).

IMPORTANT: The outer frame head of our external bi-fold door sets needs to be securely fixed to the building lintel as the sets are top hung. The frame needs to be installed perfectly square and level on all planes into the opening.

Please ensure you have read the installation instructions supplied with your door set.

Following completion of installation, all protective film and tape is to be removed immediately from the doors, frames, and glass. We cannot accept any claims relating to adhesive marks left from the protective film following installation.

Triple glazed sealed units

All glass is supplied to The GGF (glass and glazing federation) standards.

To reduce carbon emissions from the home and to keep heating and cooling bills down, the government has recommended that all manufacturers use special Low E thermal glass within the sealed unit to comply with Building Regulations Part L.

This glass is coated with a special substance to comply with the above and occasionally, and in certain light conditions may produce transient visual effects, this can sometimes look like a transparent film or haze, and make the glass appear cloudy. This is very infrequent and only affects a minority of door sets. But as a company, we do have to comply with the new regulations which are for the benefit of all, and this is not a defect.

Due to demands for better thermal efficiency, it is normal for condensation to form on the outside of the glazing units, to the exterior side of the property. This demonstrates that the glass is performing as it should by reducing the transfer of heat from the internal side of the property to the external side of the property, this is not a defect. For any condensation forming to the inside of the property, this is normally due to high levels of moisture in the air and / or insufficient ventilation in the room, the moisture is then forming on the cold surface. If condensation is forming inside the glazing unit (between the panes of glass) it is

likely that the glazing seal has been compromised.

Tempered glass means it has been toughened to be up to five times stronger than normal glass. It is unusual to break such strong glass, but sharp objects hitting the glass at certain points can cause breakage. Tempered glass is also known as safety glass. This means that if it breaks it will shatter into smaller fragments which are less likely to cause injury, unlike non-tempered glass which breaks into large, sharp fragments.

Glass must be regularly maintained and cleaned to stop break down of the glass or seals. This can be done using a mild solution such as washing-up liquid diluted in water. Do not use abrasive cleaning solutions as this may cause scratching.

Visual distortions caused by reflections in toughened glazing units are a natural phenomenon and not a fault.

Toughened, or coated glass is acceptable if bubbles or blisters, fine scratches no more than 2.5cm long and / or minute particles are neither obtrusive nor bunched. The glass used in sealed units is a processed glass therefore certain blemishes are unavoidable.

Hardware components

The exterior hardware in your Vufold bi-fold door set can deteriorate from everyday use, and also because of the weather and the local environment. That's why regular maintenance of your door hardware is even more important if you live in severe environments like coastal marine areas and some industrial locations. Even stainless-steel products require maintenance to prevent deterioration in these environments.

We require that the below minimum maintenance is carried out as often as necessary to prevent deterioration. As a guideline, we recommend that this maintenance is done every three months if you live in a marine environment, or every six months if you live in a more general location otherwise your guarantee will not be valid.

Tracks and bearings

Once your installation has been completed, and before fully operating your door set, please carefully remove any debris / swarf from the top and bottom tracks to ensure nothing comes into contact with any moving components.

After cleaning the tracks, using a microfibre cloth, apply a small amount of lubricant such as silicone spray to the inner lip of each side of the track. Make sure that the wheels pass through

the lubricant and that it spreads evenly along the track.

Extra lubricant can be added around the bearings. Adding lubricant in this way reduces wear, improves smoothness, and gives additional protection against corrosion of track and bearings. In addition, remove all surface contamination by wiping all visible track surfaces with a soft, damp cloth and mild detergent, then wipe with a clean cloth. In severe environments, apply a thin film of corrosive preventative such as silicone spray, and wipe with a clean microfibre cloth.

Stainless steel bearings are made from hardening grade stainless steel, and although this material performs much better than plated steel, it can corrode unless it is maintained as shown above.

Hinges, pivots and drop (slide) bolts

Using a microfibre cloth, wipe down the visible surfaces with warm soapy water and then rinse off by wiping with a clean, damp cloth. Applying a thin film of light machine oil or silicone spray, wiping with a dry cloth to remove any excess, will help to maintain the original lustre of the metal finish. Be careful not to get these liquids on the timber as this can cause staining.

The sliding pin and lock cylinder on the drop bolts should be maintained using silicone spray by directing the nozzle into the applicable areas. Always hold a cloth directly under the nozzle to prevent any over spray or liquid running onto the timber.

Multi-point door locks and handles

The multi-point door lock is operated by lifting the handle and turning the key. The lock is secured by top and bottom hook bolts and a central deadbolt engaging with the lock keeps. The lock should operate just as smooth with the access door in the open position as what it does when it is fully closed.

It is important that if you feel any resistance when lifting the handle, you do not continue to operate the doors as this may eventually cause the lock to fail and will invalidate your guarantee.

All moving parts should be lubricated using a silicone spray.

The handles should be regularly cleaned with a soft damp microfibre cloth to remove any dust or grime taking care not to scratch the surface.

If you experience problems with locking or unlocking the doors, first eliminate actual lock problems by opening the access door and pulling the handle upwards and then turning

the key. If this can be done, the lock is operating normally, and the problem is likely to be due to incorrect door alignment / adjustment.

Door operational adjustments

When your doors are first installed, they may require some fine-tuning to achieve a smooth operation. All our composite bifold door sets are supplied with easy to adjust hinges.

From time to time, due to changes in the seasons or because of wear and tear in use, or if the lock is difficult to operate, it may also be necessary to carry out some hinge adjustments.

If you experience any difficulty operating your doors, including opening, closing, sliding, and locking of your doors, do not continue to use your doors as this may cause further issues and damages.

Bifold Door up / down (height) adjustment

If the doors are catching or scraping the cill and you have checked the frame head is securely fixed to the lintel, then the doors need to be adjusted up higher. Identify the pivots and intermediate carriers, for Allen key adjustment method (see FIG A), insert the Allen key provided and then turn clockwise to raise the doors and anti-clockwise to lower the doors.

FIG A: ALLEN KEY ADJUSTMENT METHOD

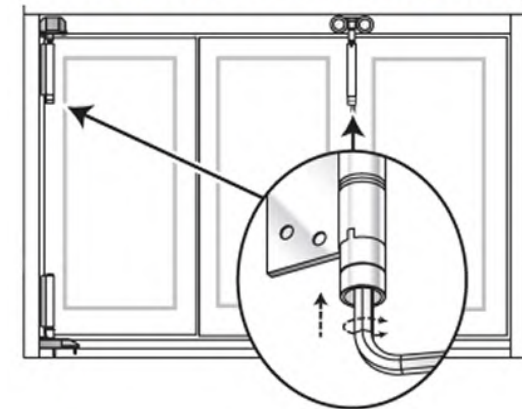

For screwdriver adjustment method (see FIG B), pull down the safety clip and use a screwdriver to adjust the doors up or down. Raise or lower the height of the doors by adjusting the top pivot and intermediate carrier.

FIG B: SCREWDRIVER ADJUSTMENT METHOD

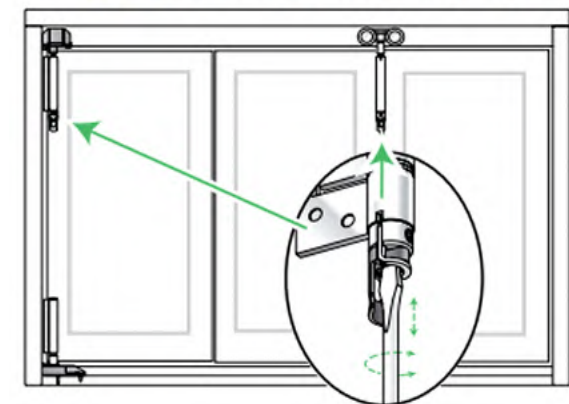

VUFOLD

Bifold Door side to side (width) adjustment

With the doors in the fully open position, access the top and bottom pivot blocks which are located inside the corners of the top and bottom tracks. Using a long / extended Philips screwdriver, turn the screw clockwise or anticlockwise to move the doors left or right, as required (see FIG C).

FIG C:

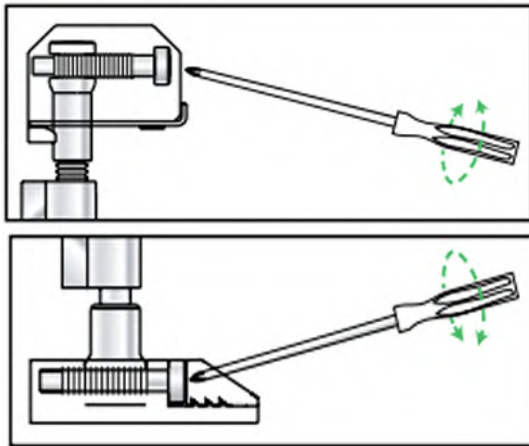

External Aluminium Sliding Patio Door sets – Status and Supreme ranges

All Vufold external aluminium sliding doors and frames, powder coating finish, double glazed sealed units, and hardware components are guaranteed for a full 15 years against the occurrence of manufacturing faults, all subject to correct installation, regular maintenance, and care in use as detailed below.

Powder Coating finish and maintenance

All our Aluminium sliding door sets are supplied fully powder coated in a satin finish providing a high quality and durable finish, unless otherwise specified.

Our standard range of colours are Anthracite grey – RAL 7016, Hipca white – RAL 9910 (Status range only), Gloss White (Supreme range only) and Jet black – RAL 9005. If you have selected an alternative custom colour option and require the colour and RAL code, please contact a Vufold team member and they will provide this for you.

To maintain the external aluminium powder-coated finish, wash regularly with soapy water and then dry off with a soft lint-free cloth. As a minimum, the external surfaces must be

washed at least every three months, and monthly if within five miles of the sea or in an industrial area. Our general recommendation would be to wash the external aluminium every time you clean your windows, which should normally be more regularly than the minimum requirement.

The powder coating is not guaranteed unless the doors are installed at least 800 metres away from the sea.

We cannot accept any claims for damages, including scratches to the powder coating and aluminium reported 72 hours following delivery, and / or after installation has commenced.

Installation

This door set is designed to be installed by a competent trades person(s) with good knowledge and previous experience of installing sliding doors.

Our aluminium doors are supplied with all the essential items, most hardware factory fitted and everything pre-machined. This design allows for simple on-site assembly by an experienced trades person(s).

The outer frame needs to be securely fixed into the opening perfectly square and level on all planes. The aluminium sliding doors are

bottom hung, the weight of the doors is supported via the sliding hardware and threshold.

IMPORTANT: The threshold must be sufficiently packed to ensure there are no dips or rises along the full length of the bottom tracks. When fixing the frame head ensure there is no bowing.

Please ensure you have read the installation instructions supplied with your door set before commencing installation.



Double glazed sealed units

All glass is supplied to The GGF (Glass and Glazing Federation) standards.

To reduce carbon emissions from the home and to keep heating and cooling bills down, the government has recommended that all manufacturers use special Low E thermal glass

within the sealed unit to comply with Building Regulations Part L.

This glass is coated with a special substance to comply with the above and occasionally, and in certain light conditions may produce transient visual effects, this can sometimes look like a transparent film or haze, and make the glass appear cloudy. This is very infrequent and only affects a minority of door sets. But as a company, we do have to comply with the new regulations which are for the benefit of all, and this is not a defect.

Due to demands for better thermal efficiency, it is normal for condensation to form on the outside of the glazing units, to the exterior side of the property. This demonstrates that the glass is performing as it should by reducing the transfer of heat from the internal side of the property to the external side of the property, this is not a defect. For any condensation forming to the inside of the property, this is normally due to high levels of moisture in the air and / or insufficient ventilation in the room, the moisture is then forming on the cold surface. If condensation is forming inside the glazing unit (between the panes of glass) it is likely that the glazing seal has been compromised.

Tempered glass means it has been toughened to be up to five times stronger than normal

glass. It is unusual to break such strong glass, but sharp objects hitting the glass at certain points can cause breakage. Tempered glass is also known as safety glass. This means that if it breaks it will shatter into smaller fragments which are less likely to cause injury, unlike non-tempered glass which breaks into large, sharp fragments.

Laminated glass is also classed as safety glass and comprises of multiple layers of glass sandwiched together. Due to its high strength, this prevents the glass from breaking into large pieces. If the glass breaks, it will produce a 'spider web' effect similar to what is commonly seen in shattered car windscreens. Laminated glass will also increase the sound rating insulation.

Glass must be regularly maintained and cleaned to stop break down of the glass or seals. This can be done using a mild solution such as washing-up liquid diluted in water. Do not use abrasive cleaning solutions as this may cause scratching.

Visual distortions caused by reflections in toughened glazing units are a natural phenomenon and not a fault.

Laminated, toughened, or coated glass is acceptable if bubbles or blisters, fine scratches no more than 2.5cm long and / or minute

particles are neither obtrusive nor bunched. The glass used in sealed units is a processed glass therefore certain blemishes are unavoidable. More blemishes may be visible in laminated glass due to the layered construction.

Hardware components

The exterior hardware in your sliding door set can deteriorate from everyday use, and also because of the weather and the local environment. That's why regular maintenance of your door hardware is even more important if you live in severe environments like coastal / marine areas and some industrial locations.

We require that the below minimum maintenance is carried out as often as necessary to prevent deterioration. As a guideline, we recommend that this maintenance is done every three months if you live in a marine environment, or every six months if you live in a more general location otherwise your guarantee will not be valid.

Tracks and bearings

Once your installation has been completed, and before fully operating your door set, please carefully remove any debris / swarf from the top and bottom tracks to ensure nothing comes into contact with any moving components.

After cleaning the tracks, using a microfibre cloth, apply a small amount of lubricant such as silicone spray to the inner lip of each side of the track.



Extra lubricant can be added around the bearings. Adding lubricant in this way reduces wear, improves smoothness, and gives additional protection against corrosion of track and bearings. In addition, remove all surface contamination by wiping all visible track surfaces with a soft, damp cloth and mild detergent, then wipe with a clean cloth. In severe environments, apply a thin film of corrosive preventative such as silicone spray, and wipe with a clean microfibre cloth.

Multi-point door locks and handles

The multi-point door lock is operated by raising and lowering the handle and turning the key.

The lock is secured by hook bolts and a central deadbolt engaging with the lock keeps. The lock should operate just as smooth with the access door in the open position as what it does when it is fully closed.

It is important that if you feel any excessive resistance when operating the handle, you do not continue to operate the doors as this may eventually cause the lock to fail and will invalidate your guarantee.

All moving parts should be lubricated using a silicone spray. The handles should be regularly cleaned with a soft damp microfibre cloth to remove any dust or grime taking care not to scratch the surface.

If you experience problems with locking or unlocking the doors, first eliminate actual lock problems by opening the access door and pulling the handle upwards and then turning the key. If this can be done, the lock is operating normally, and the problem is likely to be due to incorrect door alignment / adjustment.

Door operation

Sliding door sets have become more popular due to customers wanting to maximise the size of each glazed panel, giving more light and fewer interrupted views. The bigger the glass area the heavier the individual panels will be,

which in turn will cause extra resistance when operating the heavier doors.

All our aluminium sliding door sets have been pre-assembled in our factory. They are installed into a steel framed testing rig where they are then fully operated, including checking the doors lock and unlock smoothly. The door sets are then part dismantled, packaged up ready for dispatch and onsite assembly.

If you experience any difficulty operating your doors, including opening, closing, sliding, and locking of your doors, do not continue to use your doors as this may cause further issues. Please contact a member of the Customer Service team so we can assist you further.



Wooden Front Doors- Oslo, Malmo, Stockholm, and Bergen ranges

All Vufold external wooden front doors, frames and sidelights, double glazed sealed units, and hardware components are guaranteed for a full 10 years against the occurrence of manufacturing faults, all subject to correct installation and regular maintenance and care in use as detailed below.

Door, frame, and sidelight components

All our timber components are manufactured using the latest technology to reduce warping or twisting - this is referred to in the trade as 'engineered construction'. This means we use finger jointed or laminated hardwood sections in the core and then they are over veneered. This method has proven to be stronger and less likely to cause movement of the timber than using solid sections.

No two trees produce identical grains or colour of wood, and this adds to the beauty of a natural product. We therefore cannot guarantee that all door and frame components will look exactly the same in grain and colour.

Veneers are natural products and prone to deterioration if not adequately protected with

superior quality finish. If water penetrates the finish this may cause cracks to appear or splits. In heavy moisture areas or during heavy rain periods, this may cause oak to become darker in colour or have black marks.

Unfortunately, we cannot change the properties or performance of the timber components which are natural products. We cannot therefore accept claims for any variation in the components, or cracks or splits that may appear due to moisture going into the timber. What is more, warping of wood is not a defect if it is not more than ¼ inch (6mm) when it is in its installed position.

Protective Finish and maintenance

IMPORTANT: You would normally be expected to maintain the protective finish between 2 – 5 years depending on the weather and location.

The finish on your Vufold door set must be checked every six months for deterioration, and re-coated if necessary. The finish must be regularly maintained, to ensure moisture does not enter the timber during the life of the product.

Following installation; the door and frame components must be fully inspected for any surface area damages that may have compromised the protective coating, and re-sealed where necessary.

Pre-Finished Oak

All pre-finished oak doors, frames and sidelights have been factory finished using a high build microporous wood coating system and are ready for installation. This finish offers good UV protection.



The oak components must be well maintained and re-coated as and when necessary, before the coating breaks down. Moisture must not be allowed to penetrate the timber. The length of time between re-coating depends greatly on exposure to weather and the direction the doors face. The coating will last longer in a sheltered or north facing site. However, if the site is south facing, or in a heavy weather exposure area, the finish will need maintaining more frequently.

VUFOLD

Vufold now offer maintenance kits, under the Vufold Sigma brand, which contains everything you need to maintain the finish.

The regular use of Vufold-Sigma Wood care milk 3 to 4 times a year will prolong the period before re-coating is necessary.

We do not recommend re-finishing with oil, wax, quick drying products such as Ronseal or any finish other than a medium to high build microporous wood finishing system.

Pre-Finished Grey

The grey doors, frames and sidelights have been pre-finished with a high build microporous opaque Satin wood finish. This finish offers good UV protection.



All pre-finished grey components must be well maintained and re-coated as and when necessary, before the coating breaks down. Moisture must not be allowed to penetrate the timber. The length of time between re-coating depends greatly on exposure to weather and the direction the doors face. The coating will last longer in a sheltered or north facing site. However, if the site is south facing, or in a heavy weather exposure area, the finish will need maintaining more frequently.

Vufold now offer maintenance kits, under the Vufold Sigma brand, which contains everything you need to maintain the finish.

The regular use of Vufold-Sigma Wood care milk 3 to 4 times a year will prolong the period before re-coating is necessary.

We do not recommend re-finishing with any finish other than a medium to high build microporous opaque wood finish finishing system. The RAL (colour match) paint code for the grey finish is RAL 7016 Anthracite grey.

Installation

All our wooden front doors, frames and hardware should be professionally fitted by an experienced trades person(s) with the necessary joinery skills.

The door can either be fitted into an existing frame or one of our available frames, or frame and sidelight options. Our doors and frames are designed to be cut to size on site depending on the selected option, as per the assembly instructions provided.

The frame needs to be installed perfectly square and level on all planes into the opening.

The door hardware will not be supplied pre-machined or pre-fitted to the doors or frames and will require installing as part of the on-site assembly.

Please ensure you have read the installation instructions supplied with your purchase.

Double glazed sealed units

All glass is supplied to The GGF (Glass and Glazing Federation) standards.

To reduce carbon emissions from the home and to keep heating and cooling bills down, the government has recommended that all manufacturers use special Low E thermal glass within the sealed unit to comply with Building Regulations Part L.

This glass is coated with a special substance to comply with the above and occasionally, and in certain light conditions may produce transient visual effects, this can sometimes look like a

transparent film or haze, and make the glass appear cloudy. This is very infrequent and only affects a minority of door sets. But as a company, we do have to comply with the new regulations which are for the benefit of all, and this is not a defect.

Due to demands for better thermal efficiency, it is normal for condensation to form on the outside of the glazing units, to the exterior side of the property. This demonstrates that the glass is performing as it should by reducing the transfer of heat from the internal side of the property to the external side of the property, this is not a defect. For any condensation forming to the inside of the property, this is normally due to high levels of moisture in the air and / or insufficient ventilation in the room, the moisture is then forming on the cold surface. If condensation is forming inside the glazing unit (between the panes of glass) it is likely that the glazing seal has been compromised.

Tempered glass means it has been toughened to be up to five times stronger than normal glass. It is unusual to break such strong glass, but sharp objects hitting the glass at certain points can cause breakage. Tempered glass is also known as safety glass. This means that if it breaks it will shatter into smaller fragments which are less likely to cause injury, unlike non-

tempered glass which breaks into large, sharp fragments.

Glass must be regularly maintained and cleaned to stop break down of the glass or seals. This can be done using a mild solution such as washing-up liquid diluted in water. Do not use abrasive cleaning solutions as this may cause scratching.

Visual distortions caused by reflections in toughened glazing units are a natural phenomenon and not a fault.

Toughened, or coated glass is acceptable if bubbles or blisters, fine scratches no more than 2.5cm long and / or minute particles are neither obtrusive nor bunched. The glass used in sealed units is a processed glass therefore certain blemishes are unavoidable. More blemishes may be visible in laminated glass due to the layered construction.

Hardware components

The exterior hardware for your Vufold wooden front door can deteriorate from everyday use, and also because of the weather and the local environment. That's why regular maintenance of your door hardware is even more important if you live in severe environments like coastal marine areas and some industrial locations. Even stainless-steel products require

maintenance to prevent deterioration in these environments.

We require that the below minimum maintenance is carried out as often as necessary to prevent deterioration. As a guideline, we recommend that this maintenance is done every three months if you live in a marine environment, or every three to six months if you live in a more general location otherwise your guarantee will not be valid.



Hinges

Using a microfibre cloth, wipe down the visible surfaces with warm soapy water and then rinse off by wiping with a clean, damp cloth. Applying a thin film of light machine oil or silicone spray, wiping with a dry cloth to remove any excess, will help to maintain the original lustre of the metal finish. Be careful not to get these liquids on the timber as this can cause staining.

Locks

All moving parts should be lubricated using a silicone spray and the surface cleaned with a soft damp cloth to ensure there is not a build-up of dust or debris that can damage the surface areas.

It is important that if you feel any resistance during operation, you do not continue to operate the doors as this may eventually cause the lock to fail and will invalidate your guarantee.

If you experience problems with locking or unlocking the doors, first eliminate actual lock problems by opening the door and checking if the locks work in the open position. If the lock operates as it should then this would indicate an alignment issue.

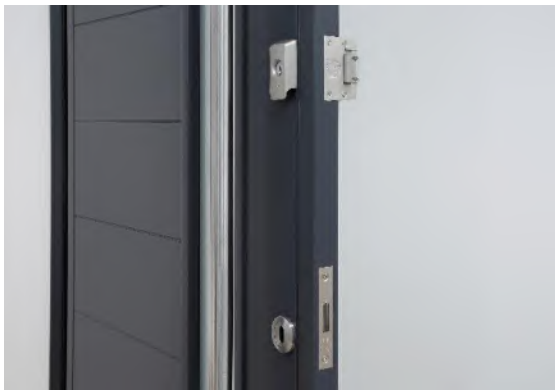

Handles, letterplates and letterboxes

The surface should be cleaned with a soft damp cloth to remove any dust or grime, taking care not to scratch the surface.

For stainless-steel furniture we recommend that all exposed stainless-steel surfaces should be wiped over with a clean cloth and warm water with a mild detergent on a frequent and routine basis.

For more stubborn dirt or stains use mild, non-scratching abrasive powders such as typical household cleaners. These can be used with warm water, bristle brushes, sponges, or clean cloths. For more aggressive cleaning a small amount of vinegar can be added to the powder.

Carbon steel brushes and steel wool should be avoided as they may leave particles embedded in the surface, which can lead to rusting. Cleaning should always be immediately followed by rinsing in clean hot water and the surface then wiped completely with a dry towel.

To maintain any stainless-steel product in the best condition, we recommend routine cleaning once a month and more often in areas subject to heavy soiling or frequent use.

Composite Front Doors – Traditional and Contemporary ranges

All Vufold external composite Front doors, uPVC frames, sidelights, double glazed sealed units, and hardware components are guaranteed for a full 10 years against the occurrence of manufacturing faults, all subject to correct installation and regular maintenance and care in use as detailed below.

Door, frame, and sidelight components

The doors are manufactured using the latest technology, constructed using a PU foam core, encased with an LVL subframe and reinforced GRP skins, reducing heat loss and providing strength and rigidity.

The outer frames are constructed from, uPVC, providing strength and low maintenance.

Protective Finish and maintenance

The composite doors are fully factory finished and ready for installation. The door leaf should be cleaned using warm soapy water and wiped dry with a microfibre cloth, or non-aggressive composite door wipes.

Do not use solvents or abrasives as they can damage the surface area of the skin.

The uPVC frames should be cleaned on a regular basis using warm soapy water. Any stains that are hard to remove can be cleaned using a specialist uPVC cleaner, in-line with the manufacturer's guidelines.



As a minimum, all external door and frame surfaces must be washed at least every three months, and monthly if within five miles of the sea or in an industrial area.

The paint finish is not guaranteed unless the doors are installed at least 800 metres away from the sea.

We cannot accept any claims for damages, including scratches to the door and / or frame reported 72 hours following delivery, and / or after installation has commenced.

The threshold should be kept clear of debris and regularly cleaned to ensure the drainage

channels remain clear, which can be done whilst cleaning the rest of the door set. The threshold should be stepped over when entering and leaving and not used as a step, to avoid damage to the threshold and seals.

Installation

Our composite front doors are supplied with all the essential items, most hardware factory fitted and everything pre-machined. This design allows for simple installation by a component DIYer or experienced trades person(s). Loose components include handles, hinge end caps and covers, and drip cill end caps.

These products are heavy so a single person must never carry out the installation alone.

The outer frame needs to be securely fixed into the opening perfectly square and level on all planes.

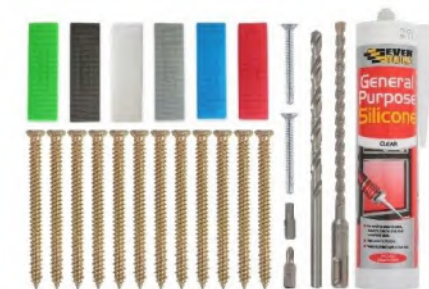

VUFOLD

Double glazed sealed units

All glass is supplied to The GGF (Glass and Glazing Federation) standards.

To reduce carbon emissions from the home and to keep heating and cooling bills down, the government has recommended that all manufacturers use special Low E thermal glass within the sealed unit to comply with Building Regulations Part L.

This glass is coated with a special substance to comply with the above and occasionally, and in certain light conditions may produce transient visual effects, this can sometimes look like a transparent film or haze, and make the glass appear cloudy. This is very infrequent and only affects a minority of door sets. But as a company, we do have to comply with the new regulations which are for the benefit of all, and this is not a defect.

Due to demands for better thermal efficiency, it is normal for condensation to form on the outside of the glazing units, to the exterior side of the property. This demonstrates that the glass is performing as it should by reducing the transfer of heat from the internal side of the property to the external side of the property, this is not a defect. For any condensation forming to the inside of the property, this is normally due to high levels of moisture in the air and / or insufficient ventilation in the room,

the moisture is then forming on the cold surface. If condensation is forming inside the glazing unit (between the panes of glass) it is likely that the glazing seal has been compromised.

Tempered glass means it has been toughened to be up to five times stronger than normal glass. It is unusual to break such strong glass, but sharp objects hitting the glass at certain points can cause breakage. Tempered glass is also known as safety glass. This means that if it breaks it will shatter into smaller fragments which are less likely to cause injury, unlike non-tempered glass which breaks into large, sharp fragments.

Laminated glass is also classed as safety glass and comprises of multiple layers of glass sandwiched together. Due to its high strength, this prevents the glass from breaking into large pieces. If the glass breaks, it will produce a 'spider web' effect similar to what is commonly seen in shattered car windscreens. Laminated glass will also increase the sound rating insulation.

Glass must be regularly maintained and cleaned to stop break down of the glass or seals. This can be done using a mild solution such as washing-up liquid diluted in water. Do not use abrasive cleaning solutions as this may cause scratching.

Visual distortions caused by reflections in toughened glazing units are a natural phenomenon and not a fault.



Laminated, toughened, or coated glass is acceptable if bubbles or blisters, fine scratches no more than 2.5cm long and / or minute particles are neither obtrusive nor bunched. The glass used in sealed units is a processed glass therefore certain blemishes are unavoidable. More blemishes may be visible in laminated glass due to the layered construction.

Hardware components

The exterior hardware for your Vufold composite front door can deteriorate from everyday use, and also because of the weather and the local environment. That's why regular maintenance of your door hardware is even more important if you live in severe environments like coastal marine areas and some industrial locations. Even stainless-steel products require maintenance to prevent deterioration in these environments.

We require that the below minimum maintenance is carried out as often as necessary to prevent deterioration. As a guideline, we recommend that this maintenance is done every three months if you live in a marine environment, or every three to six months if you live in a more general location otherwise your guarantee will not be valid.

Hinges

Using a microfibre cloth, wipe down the visible surfaces with warm soapy water and then rinse off by wiping with a clean, damp cloth. Applying a thin film of light machine oil or silicone spray, wiping with a dry cloth to remove any excess, will help to maintain the original lustre of the metal finish. Be careful not to get these liquids on the timber as this can cause staining.

Locks

All moving parts should be lubricated using a silicone spray and the surface cleaned with a soft damp cloth to ensure there is not a build-up of dust or debris that can damage the surface areas.

It is important that if you feel any resistance during operation, you do not continue to operate the doors as this may eventually cause the lock to fail and will invalidate your guarantee.

If you experience problems with locking or unlocking the doors, first eliminate actual lock problems by opening the door and checking if the locks work in the open position. If the lock operates as it should then this would indicate an alignment issue.



Handles, letterplates and letterboxes

The surface should be cleaned with a soft damp cloth to remove any dust or grime, taking care not to scratch the surface.

For stainless-steel furniture we recommend that all exposed stainless-steel surfaces should be wiped over with a clean cloth and warm water with a mild detergent on a frequent and routine basis.

For more stubborn dirt or stains use mild, non-scratching abrasive powders such as typical household cleaners. These can be used with warm water, bristle brushes, sponges, or clean cloths. For more aggressive cleaning a small amount of vinegar can be added to the powder.

Carbon steel brushes and steel wool should be avoided as they may leave particles embedded in the surface, which can lead to rusting. Cleaning should always be immediately followed by rinsing in clean hot water and the surface then wiped completely with a dry towel.

To maintain any stainless-steel product in the best condition, we recommend routine cleaning once a month and more often in areas subject to heavy soiling or frequent use.

Door operational adjustments

When your door is first installed, it should not require any adjustment. All our composite front doors have been fully assembled at our production facility, and checked for smooth operation, including the locking, and unlocking of the door.

From time to time, due to changes in the seasons or because of wear and tear in use, or if the lock is difficult to operate, it may be necessary to carry out some hinge adjustments.

If you experience any difficulty operating your doors, including, opening, closing, and locking of your doors, do not continue to use your doors as this may cause further issues and damages.

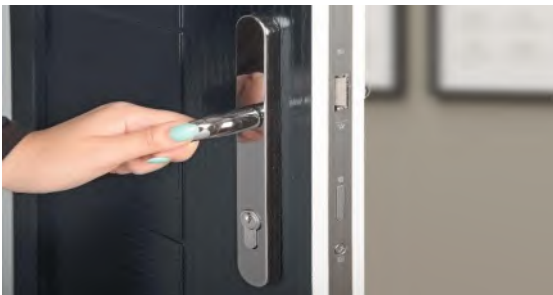

Should you need to carry out any minor adjustments to the hinges, please follow the below instructions.

The hinges can be adjusted + / - 4mm both Horizontally and Vertically (both adjustments can be carried out simultaneously).

It is recommended that air bags / wedges are used to aid with the adjustments.

To access the hinge adjustment screws, open the door to expose the grub screws, loosen off the grub screws using a 2mm Allen key and remove the cover from the hinge knuckle on all 3 hinges.



Vertical adjustment

Using a 4mm Allen key, loosen off the M5 screws on all 3 hinges. Place air bags / wedges under the door and raise or lower the door into the desired position. It may also assist placing a wedge in between the side edges of the door and frame jambs, so the door remains horizontally aligned. Finally, re-tighten all M5 adjustment screws.

Horizontal adjustment

Using a 4mm Allen key, loosen off the M5 screws on all 3 hinges. Place air bags / wedges in between the side edges of the door and frame jambs and locate the doors into the desired position. It may also assist placing a wedge under the door, so the door remains vertically aligned. Finally, re-tighten all M5 adjustment screws.



Please note; If you are experiencing any difficulties carrying out the adjustments, try loosening both screws in the middle hinge first then repeat the process adjusting the top and bottom hinges separately, tightening the hinges to secure in the adjusted position. Once you are happy the door is operating correctly, refit the hinge knuckle and tighten the grub screws using a 2mm Allen key.

Aluminium Front Doors- Signature and Designer ranges

All Vufold external aluminium front doors, frames, sidelights and hardware components are guaranteed for a full 10 years against the occurrence of manufacturing defects, the powder coating is guaranteed for 25 years, and double and triple glazed sealed units are guaranteed for 5 years, all subject to correct installation and regular maintenance and care in use as detailed below.



Powder Coating finish and maintenance

All our aluminium external front doors are supplied fully powder coated in a satin finish providing a high quality and durable finish, unless otherwise specified.

To maintain the external aluminium powder-coated finish, wash regularly with soapy water

and then dry off with a soft lint-free cloth. As a minimum, the external surfaces must be washed at least every three months, and monthly if within five miles of the sea or in an industrial area. Our general recommendation would be to wash the external aluminium every time you clean your windows, which should normally be more regularly than the minimum requirement.

The powder coating is not guaranteed unless the doors are installed at least 800 metres away from the sea.

We cannot accept any claims for damages, including scratches to the powder coating and aluminium reported 72 hours following delivery and / or after installation has commenced.

Installation

Our aluminium front doors are supplied with all the essential items, most hardware factory fitted and everything pre-machined. This design allows for simple installation by a component DIYer or experienced trades person(s). These products are heavy so a single person must never carry out the installation alone.

The outer frame needs to be securely fixed into the opening perfectly square and level on all planes.

Double and triple glazed sealed units

All glass is supplied to the GGF (glass and glazing federation) standards.

To reduce carbon emissions from the home and to keep heating and cooling bills down, the government has recommended that all manufacturers use special Low E thermal glass within the sealed unit to comply with Building Regulations Part L.

This glass is coated with a special substance to comply with the above and occasionally, and in certain light conditions may produce transient visual effects, this can sometimes look like a transparent film or haze, and make the glass appear cloudy. This is very infrequent and only affects a minority of door sets. But as a company, we do have to comply with the new regulations which are for the benefit of all, and this is not a defect.

Due to demands for better thermal efficiency, it is normal for condensation to form on the outside of the glazing units, to the exterior side of the property. This demonstrates that the glass is performing as it should by reducing the transfer of heat from the internal side of the property to the external side of the property, this is not a defect. For any condensation forming to the inside of the property, this is normally due to high levels of moisture in the air and / or insufficient ventilation in the room,

the moisture is then forming on the cold surface. If condensation is forming inside the glazing unit (between the panes of glass) it is likely that the glazing seal has been compromised.

Tempered glass means it has been toughened to be up to five times stronger than normal glass. It is unusual to break such strong glass, but sharp objects hitting the glass at certain points can cause breakage. Tempered glass is also known as safety glass. This means that if it breaks it will shatter into smaller fragments which are less likely to cause injury, unlike non-tempered glass which breaks into large, sharp fragments.

Laminated glass is also classed as safety glass and comprises of multiple layers of glass sandwiched together. Due to its high strength, this prevents the glass from breaking into large pieces. If the glass breaks, it will produce a 'spider web' effect similar to what is commonly seen in shattered car windscreens. Laminated glass will also increase the sound rating insulation.

Glass must be regularly maintained and cleaned to stop break down of the glass or seals. This can be done using a mild solution such as washing-up liquid diluted in water. Do not use abrasive cleaning solutions as this may cause scratching.

Visual distortions caused by reflections in toughened glazing units are a natural phenomenon and not a fault.

Laminated, toughened, or coated glass is acceptable if bubbles or blisters, fine scratches no more than 2.5cm long and / or minute particles are neither obtrusive nor bunched. The glass used in sealed units is a processed glass therefore certain blemishes are unavoidable. More blemishes may be visible in laminated glass due to the layered construction.

Hardware components

The exterior hardware for your Vufold aluminium front door can deteriorate from everyday use, and also because of the weather and the local environment. That's why regular maintenance of your door hardware is even more important if you live in severe environments like coastal marine areas and some industrial locations. Even stainless-steel products require maintenance to prevent deterioration in these environments.

We require that the below minimum maintenance is carried out as often as necessary to prevent deterioration. As a guideline, we recommend that this maintenance is done every three months if you live in a marine environment, or every three to

six months if you live in a more general location otherwise your guarantee will not be valid.

Hinges

Using a microfibre cloth, wipe down the visible surfaces with warm soapy water and then rinse off by wiping with a clean, damp cloth. Applying a thin film of light machine oil or silicone spray, wiping with a dry cloth to remove any excess, will help to maintain the original lustre of the metal finish. Be careful not to get these liquids on the timber as this can cause staining.

Locks

All moving parts should be lubricated using a silicone spray and the surface cleaned with a soft damp cloth to ensure there is not a build-up of dust or debris that can damage the surface areas.

If you experience problems with locking or unlocking the doors, first eliminate actual lock problems by opening the access door and checking if the locks work in the open position. If the lock operates as it should then this would indicate an alignment issue.

Handles, letterplates and letterboxes

The surface should be cleaned with a soft damp cloth to remove any dust or grime, taking care not to scratch the surface.

For stainless-steel furniture we recommend that all exposed stainless-steel surfaces should be wiped over with a clean cloth and warm water with a mild detergent on a frequent and routine basis.

For more stubborn dirt or stains use mild, non-scratching abrasive powders such as typical household cleaners. These can be used with warm water, sponges, or clean cloths. For more aggressive cleaning a small amount of vinegar can be added to the powder.

Carbon steel brushes and steel wool should be avoided as they may leave particles embedded in the surface, which can lead to rusting. Cleaning should always be immediately followed by rinsing in clean hot water and the surface then wiped completely with a dry towel.

To maintain any stainless-steel product in the best condition, we recommend routine cleaning once a month and more often in areas subject to heavy soiling or frequent use

Door operation

When your door is first installed, it should not require any adjustment. All our aluminium

front doors have been fully assembled at our production facility, and checked for smooth operation, including the locking, and unlocking of the door.

From time to time, due to changes in the seasons or because of wear and tear in use, or if the lock is difficult to operate, it may be necessary to carry out some hinge adjustments.

If you experience any difficulty operating your doors, including, opening, closing, and locking of your doors, do not continue to use your doors as this may cause further issues and damages, and will invalidate your guarantee.

Auto locks have an auto latch feature for added security. Please be aware, certain users may find it more difficult to operate when compared to a manual lock due to operation via a thumb turn cylinder only and lacking a traditional lever handle.



Roof Glazing – Roof Light and Roof Lantern ranges

All Vufold roof glazing frames, powder coating finish and double-glazed sealed units are guaranteed for a full 10 years against the occurrence of manufacturing faults, all subject to correct installation and regular maintenance and care in use as detailed below.

Powder Coating finish and maintenance

All our Aluminium external roof light and roof lanterns are supplied fully powder coated in a satin finish providing a high quality and durable finish, unless otherwise specified.



Our standard range of colours are Anthracite grey – RAL 7016, Hipca white – RAL 9910, and Jet black – RAL 9005. If you have selected an alternative custom colour option and require

the colour and RAL code, please contact a Vufold team member and they will provide this for you.

To maintain the external aluminium powder-coated finish, wash regularly with soapy water and then dry off with a soft lint-free cloth. As a minimum, the external surfaces must be washed at least every three months, and monthly if within five miles of the sea or in an industrial area. Our general recommendation would be to wash the external aluminium every time you clean your windows, which should normally be more regularly than the minimum requirement.

The powder coating is not guaranteed unless the roof glazing is installed at least 800 metres away from the sea.

We cannot accept any claims for damages, including scratches to the powder coating and aluminium reported 72 hours following delivery, and / or after installation has commenced.

Installation

All our roof lights and roof lanterns must be professionally installed by an experienced trades person(s) with the necessary skills.

Roof Glazing – Roof Light and Roof Lantern ranges

IMPORTANT: All roof glazing must be installed onto an appropriate kerb and sealed using a suitable weatherproof membrane (not provided). Roof lights must be installed with a minimum of a 5-degree pitch.

Please ensure you have read the installation instructions supplied with your purchase.

Double glazed sealed units

All glass is supplied to The GGF (Glass and Glazing Federation) standards.

To reduce carbon emissions from the home and to keep heating and cooling bills down, the government has recommended that all manufacturers use special Low E thermal glass within the sealed unit to comply with Building Regulations Part L.

This glass is coated with a special substance to comply with the above and occasionally, and in certain light conditions may produce transient visual effects, this can sometimes look like a transparent film or haze, and make the glass appear cloudy. This is very infrequent and only affects a minority of roof glazing. But as a company, we do have to comply with the new regulations which are for the benefit of all, and this is not a defect.

Due to demands for better thermal efficiency, it is normal for condensation to form on the outside of the glazing units, to the exterior side of the property. This demonstrates that the glass is performing as it should by reducing the transfer of heat from the internal side of the property to the external side of the property, this is not a defect. For any condensation forming to the inside of the property, this is normally due to high levels of moisture in the air and / or insufficient ventilation in the room, the moisture is then forming on the cold surface. If condensation is forming inside the glazing unit (between the panes of glass) it is likely that the glazing seal has been compromised.



Tempered glass means it has been toughened to be up to five times stronger than normal glass. It is unusual to break such strong glass, but sharp objects hitting the glass at certain

points can cause breakage. Tempered glass is also known as safety glass. This means that if it breaks it will shatter into smaller fragments which are less likely to cause injury, unlike non-tempered glass which breaks into large, sharp fragments.

Glass must be regularly maintained and cleaned to stop break down of the glass or seals. This can be done using a mild solution such as washing-up liquid diluted in water. Do not use abrasive cleaning solutions as this may cause scratching.

Visual distortions caused by reflections in toughened glazing units are a natural phenomenon and not a fault.

Toughened, or coated glass is acceptable if bubbles or blisters, fine scratches no more than 2.5cm long and / or minute particles are neither obtrusive nor bunched. The glass used in sealed units is a processed glass therefore certain blemishes are unavoidable.



Aluminium Windows – Casement, Flush Casement, Urban Casement and Tilt & Turn ranges

Powder Coating finish and maintenance

All our Aluminium windows are supplied fully powder coated in a satin finish providing a high quality and durable finish, unless otherwise specified.

Our current standard range of colours are Anthracite grey – RAL 7016, White, and Jet black – RAL 9005. If you have selected an alternative custom colour option, or have not ordered our current window range, and require confirmation of the colour and RAL code, please contact a Vufold team member and they will provide this for you.



To maintain the external aluminium powder-coated finish, wash regularly with soapy water and then dry off with a soft lint-free cloth. As a minimum, the external surfaces must be washed at least every three months, and monthly if within five miles of the sea or in an industrial area. Our general recommendation would be to wash the external aluminium profiles every time you clean your glass, which should normally be more regularly than the minimum requirement.

The powder coating is not guaranteed unless the windows are installed at least 800 metres away from the sea.

We cannot accept any claims for damages, including scratches to the powder coating and aluminium reported 72 hours following delivery, and / or after installation has commenced.

Installation

All our external aluminium windows are supplied with all the essential items, most hardware factory fitted and everything pre-machined. This design allows for simple on-site assembly by an experienced trades person(s).

The outer frame needs to be securely fixed into the opening perfectly square and level on all planes.

Please ensure you have read the installation instructions supplied with your window(s).

Double glazed sealed units

All glass is supplied to The GGF (Glass and Glazing Federation) standards.

To reduce carbon emissions from the home and to keep heating and cooling bills down, the government has recommended that all manufacturers use special Low E thermal glass within the sealed unit to comply with Building Regulations Part L.

This glass is coated with a special substance to comply with the above and occasionally, and in certain light conditions may produce transient visual effects, this can sometimes look like a transparent film or haze, and make the glass appear cloudy. This is very infrequent and only affects a minority of windows. But as a company, we do have to comply with the new regulations which are for the benefit of all, and this is not a defect.

Due to demands for better thermal efficiency, it is normal for condensation to form on the outside of the glazing units, to the exterior side of the property. This demonstrates that the glass is performing as it should by reducing the transfer of heat from the internal side of the property to the external side of the property, this is not a defect. For any condensation

forming to the inside of the property, this is normally due to high levels of moisture in the air and / or insufficient ventilation in the room, the moisture is then forming on the cold surface. If condensation is forming inside the glazing unit (between the panes of glass) it is likely that the glazing seal has been compromised.

Tempered glass means it has been toughened to be up to five times stronger than normal glass. It is unusual to break such strong glass, but sharp objects hitting the glass at certain points can cause breakage. Tempered glass is also known as safety glass. This means that if it breaks it will shatter into smaller fragments which are less likely to cause injury, unlike non-tempered glass which breaks into large, sharp fragments.

Laminated glass is also classed as safety glass and comprises of multiple layers of glass sandwiched together. Due to its high strength, this prevents the glass from breaking into large pieces. If the glass breaks, it will produce a 'spider web' effect similar to what is commonly seen in shattered car windscreens. Laminated glass will also increase the sound rating insulation.

Glass must be regularly maintained and cleaned to stop break down of the glass or seals. This can be done using a mild solution

such as washing-up liquid diluted in water. Do not use abrasive cleaning solutions as this may cause scratching.

Visual distortions caused by reflections in toughened glazing units are a natural phenomenon and not a fault.



Laminated, toughened, or coated glass is acceptable if bubbles or blisters, fine scratches no more than 2.5cm long and / or minute particles are neither obtrusive nor bunched. The glass used in sealed units is a processed glass therefore certain blemishes are unavoidable. More blemishes may be visible in laminated glass due to the layered construction.

Hardware components

The exterior hardware in your Vufold windows can deteriorate from everyday use, and also

because of the weather and the local environment. That's why regular maintenance of your window hardware is even more important if you live in severe environments like coastal / marine areas and some industrial locations.

We require that the below minimum maintenance is carried out as often as necessary to prevent deterioration. As a guideline, we recommend that this maintenance is done every three months if you live in a marine environment, or every six months if you live in a more general location otherwise your guarantee will not be valid.

Hinges & stays

Using a microfibre cloth, wipe down the visible surfaces with warm soapy water and then rinse off by wiping with a clean, damp cloth. Applying a thin film of light machine oil or silicone spray, wiping with a dry cloth to remove any excess, will help to maintain the original lustre of the metal finish. Be careful not to get these liquids on the aluminium as this may affect the powder coating.

Locks and handles

All moving parts should be lubricated using a silicone spray.

The handles should be regularly cleaned with a soft damp microfibre cloth to remove any dust or grime taking care not to scratch the surface.

It is important that if you feel any resistance operating the lock and handle, you do not continue to operate the windows as this may eventually cause the lock to fail and will invalidate your guarantee.

If you experience problems with locking or unlocking the windows, first eliminate actual lock problems by opening the window, turn the handle and then turn the key. If this can be done, the lock is operating normally, and the problem is likely to be due to incorrect alignment.

Window operation

All our aluminium windows have been pre-assembled in our factory. They are installed into a steel framed testing rig where they are glazed / toe and healed and then fully operated, including checking the windows lock and unlock smoothly.

If you experience any difficulty operating your windows including opening, closing, and locking of your windows, do not continue to use your windows as this may cause further issues and damages. Please contact a member of the Customer Service team so we can assist you further.



UPVC Windows – Casement and Flush Casement

All Vufold external uPVC windows, double and triple glazed sealed units, and hardware components are guaranteed for a full 10 years against the occurrence of manufacturing faults, all subject to correct installation, regular maintenance, and care in use as detailed below.

White uPVC and foil finishes, care and maintenance

All our uPVC windows are supplied in either a standard white uPVC finish or using foils.

To maintain the window profiles, wash regularly with soapy water and then dry off with a soft lint-free cloth. As a minimum, the external surfaces must be washed at least every three to six months, and monthly if within five miles of the sea or in an industrial area. Our general recommendation would be to wash the window profiles every time you clean your glass, which should normally be more regularly than the minimum requirement.

You should avoid using any cleaning agents that are abrasive or contain ammonia. Do not use any type of bleach solvent or adhesive.

The uPVC is not guaranteed unless installed at least 800 metres away from the sea.

We cannot accept any claims for damages, including scratches to the uPVC reported 72 hours following delivery, and / or after installation has commenced.

Installation

All our external uPVC windows are supplied with all the essential items, most hardware factory fitted and everything pre-machined. This design allows for simple on-site assembly by an experienced trades person(s).

The outer frame needs to be securely fixed into the opening perfectly square and level on all planes.

Please ensure you have read the installation instructions supplied with your window(s).

Double glazed sealed units

All glass is supplied to The GGF (Glass and Glazing Federation) standards.

To reduce carbon emissions from the home and to keep heating and cooling bills down, the government has recommended that all manufacturers use special Low E thermal glass within the sealed unit to comply with Building Regulations Part L.

This glass is coated with a special substance to comply with the above and occasionally, and in certain light conditions may produce transient visual effects, this can sometimes look like a transparent film or haze, and make the glass appear cloudy. This is very infrequent and only affects a minority of windows. But as a company, we do have to comply with the new regulations which are for the benefit of all, and this is not a defect.

Due to demands for better thermal efficiency, it is normal for condensation to form on the outside of the glazing units, to the exterior side of the property. This demonstrates that the glass is performing as it should by reducing the transfer of heat from the internal side of the property to the external side of the property, this is not a defect. For any condensation forming to the inside of the property, this is normally due to high levels of moisture in the air and / or insufficient ventilation in the room, the moisture is then forming on the cold surface. If condensation is forming inside the glazing unit (between the panes of glass) it is likely that the glazing seal has been compromised.

Tempered glass means it has been toughened to be up to five times stronger than normal glass. It is unusual to break such strong glass, but sharp objects hitting the glass at certain points can cause breakage. Tempered glass is

also known as safety glass. This means that if it breaks it will shatter into smaller fragments which are less likely to cause injury, unlike non-tempered glass which breaks into large, sharp fragments.

Laminated glass is also classed as safety glass and comprises of multiple layers of glass sandwiched together. Due to its high strength, this prevents the glass from breaking into large pieces. If the glass breaks, it will produce a 'spider web' effect similar to what is commonly seen in shattered car windscreens. Laminated glass will also increase the sound rating insulation.

Glass must be regularly maintained and cleaned to stop break down of the glass or seals. This can be done using a mild solution such as washing-up liquid diluted in water. Do not use abrasive cleaning solutions as this may cause scratching.

Visual distortions caused by reflections in toughened glazing units are a natural phenomenon and not a fault.

Laminated, toughened, or coated glass is acceptable if bubbles or blisters, fine scratches no more than 2.5cm long and / or minute particles are neither obtrusive nor bunched. The glass used in sealed units is a processed glass therefore certain blemishes

are unavoidable. More blemishes may be visible in laminated glass due to the layered construction.

Hardware components

The exterior hardware on your Vufold windows can deteriorate from everyday use, and also because of the weather and the local environment. That's why regular maintenance of your window hardware is even more important if you live in severe environments like coastal / marine areas and some industrial locations.

We require that the below minimum maintenance is carried out as often as necessary to prevent deterioration. As a guideline, we recommend that this maintenance is done every three months if you live in a marine environment, or every six months if you live in a more general location otherwise your guarantee will not be valid.

Hinges & stays

Keep the friction stay track free from dirt and grime and keep the hinge mechanism clean. Lubricate the metal parts regularly with light oil, concentrating on the pivot points.

Locks and handles

Apply light oil to the moving parts, once a year. Similarly, a little grease should be applied to the locking slots to facilitate smooth running.

The handles should be regularly cleaned with a soft damp microfibre cloth to remove any dust or grime taking care not to scratch the surface.

It is important that if you feel any resistance operating the lock and handle, you do not continue to operate the windows as this may eventually cause the lock to fail and will invalidate your guarantee.

If you experience problems with locking or unlocking the windows, first eliminate actual lock problems by opening the window, turn the handle and then turn the key. If this can be done, the lock is operating normally, and the problem is likely to be due to incorrect alignment.

Window operation

All our uPVC windows have been pre-assembled in our factory. They are tested to ensure they are fully operational, including checking the windows lock and unlock smoothly.

Internal Wooden Bifold Door Sets- Finesse, Urban and Edge ranges

All Vufold internal wooden doors and frames, single glazed sealed units, and hardware components are guaranteed for a full 15 years against the occurrence of manufacturing faults, all subject to correct installation and regular maintenance and care in use as detailed below.



Door and frame components

All our timber components are manufactured using the latest technology to reduce warping or twisting. They are constructed using an engineered wooden core, solid wood lipping's and faced using real wooden veneers.

No two trees produce identical grains or colour of wood, and this adds to the beauty of a natural product. We therefore cannot guarantee that all door and frame components will look exactly the same in grain and colour.

Veneers are natural products and prone to deterioration if not fully sealed with superior quality finish. If moisture penetrates the finish this may cause cracks to appear or splits.

Unfortunately, we cannot change the properties or performance of the timber components which are natural products. We cannot therefore accept claims for any variation in the components, or cracks or splits that may appear due to moisture going into the timber. What is more, warping of wood is not a defect if it is not more than ¼ inch (6mm) when it is in its installed position.

Protective finish and maintenance

IMPORTANT: We recommend the coating is checked every 2 – 5 years and recoated if necessary. The coating may require more regular attention if installed say between a kitchen and living area or separating a lounge and dining area with a log burner, or directly next to a radiator due to regular varying temperature changes and moisture rich environments.

Finesse, Urban and Edge Unfinished Oak Door sets

All unfinished oak internal door sets must be fully finished according to our guidelines BEFORE the door set is installed. Failure to do so will invalidate the guarantee.

Please note that the use of steel wool or allowing steel or iron fragments to come into contact with the untreated oak timber or veneers may cause oxidisation resulting in black staining.



Your internal unfinished oak door set(s) must be finished with an internal polyurethane varnish or paint in your preferred colour and gloss level. This should consist of a minimum of 3 coats to **ALL** faces and edges of the doors and frame components to ensure the product is fully sealed, including the tops and bottom edges of the doors.

If you are looking for a durable and more natural finish, we recommend using Dulux Trade clear polyurethane varnish in a satin finish. It is important that you have tested and checked that you are happy with your choice of finish before applying to your door set. Please note, even clear finishes will darken the timber from its original appearance.

IMPORTANT: Do not use any oil, wax, quick drying products such as Ronseal or any finish other than a polyurethane finish as this will invalidate your guarantee.

Finesse White Primed Plus Door sets

The white internal doors sets have been primed with a polyurethane satin white wood finish. This finish is classed as a base coat finish; however, it still offers good protection against natural moisture in the air and general temperature changes.

The doors can be installed as supplied, however should you wish to apply a final coat, we recommend using a polyurethane finishing system. The RAL (colour match) paint code for the base coat white finish is 9016 Traffic White.

We cannot accept any claims for blemishes in the paint work as it is supplied as a base coat finish and may require a final topcoat, depending on your personal preference.

Installation

Our ready-to-assemble internal wooden doors are supplied with all the essential items and virtually everything pre-machined. This design allows for simple on-site assembly by a competent DIYer or experienced trades person(s).

IMPORTANT: The outer frame head of our internal bi-fold door sets needs to be securely fixed to the building lintel as the door sets are top hung. The frame needs to be installed perfectly square and level on all planes into the opening.

How to Install a Wooden Internal bifold door - Vufold.

Single glazed units

All glass is supplied to The GGF (Glass and Glazing Federation) standards.

Tempered glass means it has been toughened to be up to five times stronger than normal glass. It is unusual to break such strong glass, but sharp objects hitting the glass at certain points can cause breakage. Tempered glass is also known as safety glass. This means that if it breaks it will shatter into smaller fragments which are less likely to cause injury, unlike non-tempered glass which breaks into large, sharp fragments.

Glass must be regularly maintained and cleaned. This can be done using a mild solution such as washing-up liquid diluted in water. Do not use abrasive cleaning solutions as this may cause scratching.

Visual distortions caused by reflections in toughened glass are a natural phenomenon and not a fault.

Toughened, glass is acceptable if bubbles or blisters, fine scratches no more than 2.5cm long and / or minute particles are neither obtrusive nor bunched. The glass used is a processed glass therefore certain blemishes are unavoidable.

Hardware components

The hardware in your internal Vufold bi-fold door set can deteriorate from everyday use. That's why regular maintenance of your door hardware is important.

We require that the below minimum maintenance is carried out as often as necessary to prevent deterioration. As a guideline, we recommend that this maintenance is done every six months otherwise your guarantee will not be valid.

Tracks and bearings

Once your installation has been completed, and before fully operating your door set,

please carefully remove any debris / swarf from the top and bottom tracks to ensure nothing comes into contact with any moving components.

After cleaning the tracks, using a microfibre cloth, apply a small amount of lubricant such as silicone spray to the inner lip of each side of the track. Make sure that the wheels pass through the lubricant and that it spreads evenly along the track.

Extra lubricant can be added around the bearings. Adding lubricant in this way reduces wear, improves smoothness, and gives additional protection against corrosion of track and bearings. In addition, remove all surface contamination by wiping all visible track surfaces with a soft, damp cloth and mild detergent, then wipe with a clean cloth. In severe environments, apply a thin film of corrosive preventative such as silicone spray, and wipe with a clean microfibre cloth.

Stainless-steel bearings are made from hardening grade stainless-steel, and although this material performs much better than plated steel, it can corrode unless it is maintained as shown above.

Hinges, pivots and drop (slide) bolts

Using a microfibre cloth, wipe down the visible surfaces with warm soapy water and then rinse

off by wiping with a clean, damp cloth. Applying a thin film of light machine oil or silicone spray, wiping with a dry cloth to remove any excess, will help to maintain the original lustre of the metal finish. Be careful not to get these liquids on the timber as this can cause staining.

The sliding pin on the drop bolts should be maintained using silicone spray by directing the nozzle into the applicable areas. Always hold a cloth directly under the nozzle to prevent any over spray or liquid running onto the timber.

Door latch and handles

The handle and latch should operate just as smooth with the access door in the open position as what it does when it is fully closed.



It is important that if you feel any resistance when operating the handle, you do not continue to operate the doors as this may eventually cause the latch to fail and will invalidate your guarantee.

All moving parts should be lubricated using a silicone spray.

The handles should be regularly cleaned with a soft damp microfibre cloth to remove any dust or grime taking care not to scratch the surface.

If you experience problems opening and closing the doors, first eliminate the actual latch problems by opening the access door and pulling the handle downwards to retract the latch. If this can be done, the latch is operating normally, and the problem is likely to be due to incorrect door alignment / adjustment.

Door operational adjustments

When your doors are first installed, they may require some fine-tuning to achieve a smooth operation. All our wooden internal door sets are supplied with easy to adjust hinges.

From time to time, due to changes in the temperature or because of general wear and tear in use, or if the door is difficult to operate, it may also be necessary to carry out some hinge adjustments.

If you experience any difficulty operating your doors, including, opening, closing, and sliding your doors, do not continue to use your doors as this may cause further issues and damages.

Up / down (height) adjustment

If the doors are catching or scraping the cill / floor and you have checked the frame head is securely fixed to the lintel, then the doors need to be adjusted up higher. Identify the pivots and intermediate carriers, for Allen key adjustment method (see FIG A), insert the Allen key provided and then turn clockwise to raise the doors and anti-clockwise to lower the doors.

FIG A: ALLEN KEY ADJUSTMENT METHOD

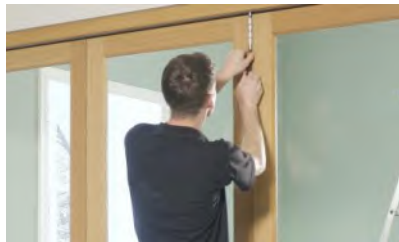
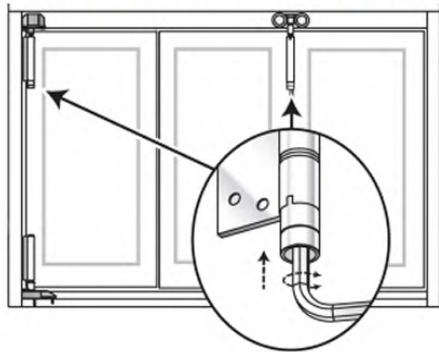

For screwdriver adjustment method (see FIG B), pull down the safety clip and use a screwdriver to adjust the doors up or down. Raise or lower the height of the doors by adjusting the top pivot and intermediate carrier.

FIG B: SCREWDRIVER ADJUSTMENT METHOD

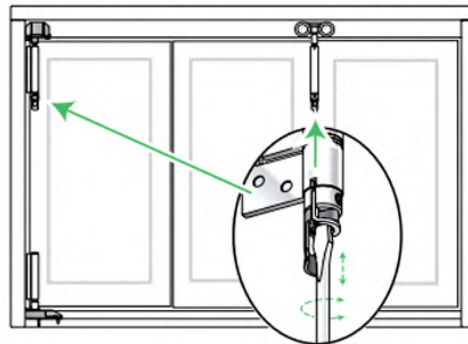

Side to side (width) adjustment (with bottom track)

With the doors in the fully open position, access the top and bottom pivot blocks which are located inside the corners of the top and bottom tracks. Using a long / extended Philips screwdriver, turn the screw clockwise or anticlockwise to move the doors left or right, as required (see FIG C).

FIG C

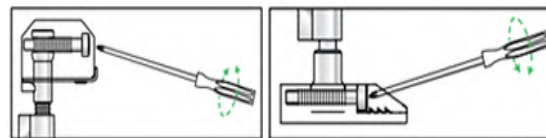

Side to side (width) adjustment (without bottom track)

With the doors in the fully open position, access the top pivot block which is located inside the corners of the top track, and the bottom wall pivot fixed to the lower frame jamb. Using a long / extended Philips screwdriver, turn the screw clockwise or anticlockwise to move the doors left or right, as required (see FIG D).

FIG D: WITHOUT BOTTOM TRACK ADJUSTMENT

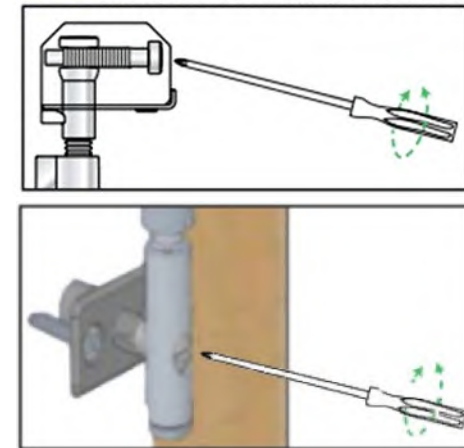

Internal Fold Flat Door sets – Inspire ranges

All Vufold Inspire wooden doors and frames, single glazed sealed units, and hardware components are guaranteed for a full 15 years against the occurrence of manufacturing faults, all subject to correct installation and regular maintenance and care in use as detailed below.



Door and frame components

All our timber components are manufactured using the latest technology to reduce warping or twisting. They are constructed using an engineered wooden core, solid wood lipping's and faced using real wooden veneers.

No two trees produce identical grains or colour of wood, and this adds to the beauty of a natural product. We therefore cannot guarantee that all door and frame components will look exactly the same in grain and colour.

Veneers are natural products and prone to deterioration if not fully sealed with superior quality finish. If moisture penetrates the finish this may cause cracks to appear or splits.

Unfortunately, we cannot change the properties or performance of the timber components which are natural products. We cannot therefore accept claims for any variation in the components, or cracks or splits that may appear due to moisture going into the timber.

Protective Finish and maintenance

IMPORTANT: We recommend the coating on your internal doors is checked every 2 – 5 years and recoated if necessary. The coating may require more regular attention if installed say between a kitchen and living area or separating a lounge and dining area with a log burner, or directly next to a radiator due to regular varying temperature changes and moisture rich environments.

Inspire Oak Door sets

All unfinished oak internal door sets must be full finished according to our guidelines

BEFORE the door set is installed. Failure to do so will invalidate the guarantee.

Please note that the use of steel wool or allowing steel or iron fragments to come into contact with the untreated oak timber or veneers may cause oxidisation resulting in black staining.

Internal unfinished oak door sets must be finished with an internal polyurethane varnish or paint in your preferred colour and gloss level. This should consist of a minimum of 3 coats to **ALL** faces and edges of the doors and frame components to ensure the product is fully sealed, including the tops and bottom edges of the doors. If you are looking for a durable and more natural finish, we recommend using Dulux Trade clear polyurethane varnish in a satin finish. It is important that you have tested and checked that you are happy with your choice of finish before applying to your door set. Please note, even clear finishes will darken the timber from its original appearance.

IMPORTANT: Do not use any oil, wax, quick drying products such as Ronseal or any finish other than a polyurethane finish as this will invalidate your guarantee.

Inspire White Primed Plus Door sets

The white internal Urban Fold flat door sets have been primed with a polyurethane satin white wood finish. This finish is classed as a base coat finish; however, it still offers good protection against natural moisture in the air and general temperature changes.



The doors can be installed as supplied, however should you wish to apply a final coat, we recommend using a polyurethane finishing system. The RAL (colour match) paint code for the base coat white finish is 9016 Traffic White.

We cannot accept any claims for blemishes in the paint work as it is supplied as a base coat finish and may require a final topcoat, depending on personal preference.

Urban Inspire Primed Plus Door Sets

The black internal Urban Fold flat door sets have been primed with a polyurethane matt black wood finish. This finish is classed as a base coat finish; however, it still offers good protection against natural moisture in the air and general temperature changes.

The doors can be installed as supplied, however should you wish to apply a final coat, we recommend using a polyurethane finishing system. The RAL (colour match) paint code for the base coat black finish is 9011 Graphite Black.

We cannot accept any claims for blemishes in the paint work as it is supplied as a base coat finish and may require a final topcoat, depending on personal preference.



Installation

Our ready-to-assemble internal Inspire doors are supplied with all the essential items and virtually everything pre-machined. This design allows for simple on-site assembly by a competent DIYer or experienced trades person(s).

IMPORTANT: The bottom pivot blocks and outer frame side jambs need to be installed onto your finished floor level, ensuring the outer frame is installed perfectly square and level on all planes into the opening. If you are installing the doors before laying the floor, it is vital that you have sufficient spacing underneath the frame jambs, and also pack under the bottom pivot blocks so the bottom of the pivot blocks are sitting flush and level with the bottom of the frame jambs.

Single glazed units

All glass is supplied to The GGF (Glass and Glazing Federation) standards.

Tempered glass means it has been toughened to be up to five times stronger than normal glass. It is unusual to break such strong glass, but sharp objects hitting the glass at certain points can cause breakage.

Tempered glass is also known as safety glass. This means that if it breaks it will shatter into smaller fragments which are less likely to cause injury, unlike non-tempered glass which breaks into large, sharp fragments.

Glass must be regularly maintained and cleaned. This can be done using a mild solution such as washing-up liquid diluted in water. Do not use abrasive cleaning solutions as this may cause scratching.

Visual distortions caused by reflections in toughened glass are a natural phenomenon and not a fault.

Toughened, glass is acceptable if bubbles or blisters, fine scratches no more than 2.5cm long and / or minute particles are neither obtrusive nor bunched. The glass used is a processed glass therefore certain blemishes are unavoidable.

Hardware components

The hardware in your internal Vufold Inspire door set can deteriorate from everyday use. That's why regular maintenance of your door hardware is important.

We require that the below minimum maintenance is carried out as often as necessary to prevent deterioration. As a guideline, we recommend that this

maintenance is done every six months otherwise your guarantee will not be valid.

Hinges, pivots and drop (slide) bolts

Using a microfibre cloth, wipe down the visible surfaces with warm soapy water and then rinse off by wiping with a clean, damp cloth. Applying a thin film of light machine oil or silicone spray, wiping with a dry cloth to remove any excess, will help to maintain the original lustre of the metal finish. Be careful not to get these liquids on the timber as this can cause staining.

The sliding pin on the drop bolts should be maintained using silicone spray by directing the nozzle into the applicable areas. Always hold a cloth directly under the nozzle to prevent any over spray or liquid running onto the timber.

Door latch and handles

The handle and latch should operate just as smooth with the access door in the open position as what it does when it is fully closed.

It is important that if you feel any resistance when operating the handle, you do not continue to operate the doors as this may eventually cause the latch to fail and will invalidate your guarantee.

All moving parts should be lubricated using a silicone spray.

The handles should be regularly cleaned with a soft damp microfibre cloth to remove any dust or grime taking care not to scratch the surface. If you experience problems opening and closing the doors, first eliminate the actual latch problems by opening the access door and pulling the handle downwards. If this can be done, the latch is operating normally, and the problem is likely to be due to incorrect door alignment / adjustment.

Door operational adjustments

When your doors are first installed, they may require some fine tuning to achieve a smooth operation. All our wooden internal door sets are supplied with easy to adjust hinges.

From time to time, due to changes in the temperature or because of general wear and tear in use, or if the door is difficult to operate, it may also be necessary to carry out some hinge adjustments.

If you experience any difficulty operating your doors, including, opening, and closing your doors, do not continue to use your doors as this may cause further issues and damages.

Up / down (height) adjustment

If the doors are catching or scraping the threshold / floor and you have checked the frame is level and the bottom pivot block are installed as per the assembly instructions, then carry out the below height adjustment.

Raise or lower the height of the doors by adjusting the bottom pivot hinge, using the spanner and screwdriver provided.

Locate the adjustment slot on the bottom pivot hinge(s) insert the screwdriver at an angle pointing downwards and then slide the mechanism upwards to disengage it (do not push it in), use the spanner to turn the nut left or right to raise or lower the doors. Once you have done a complete revolution, the release mechanism will return to the locked position. Repeat the process should you need to adjust further.

IMPORTANT: Do not try and push or force the release mechanism or nut as you may damage it during this process and invalidate your warranty.

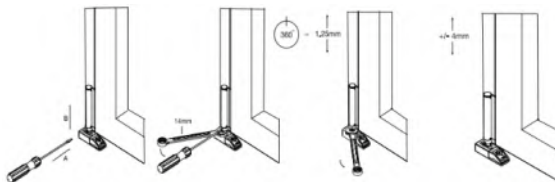

Side to side (width) adjustment

If the doors feel too tight on one side of the frame and / or you are struggling to engage the latch, firstly check the frame is level and the bottom pivot block are installed as per the assembly instructions, please also check that the draught seals are installed in the correct location.

With the doors in the fully open position, access the top pivot block(s) which is located inside the corner(s) of the frame head, and the bottom pivot block(s). Using a long / extended Philips screwdriver, turn the screw clockwise or anticlockwise to move the doors left or right, as required.

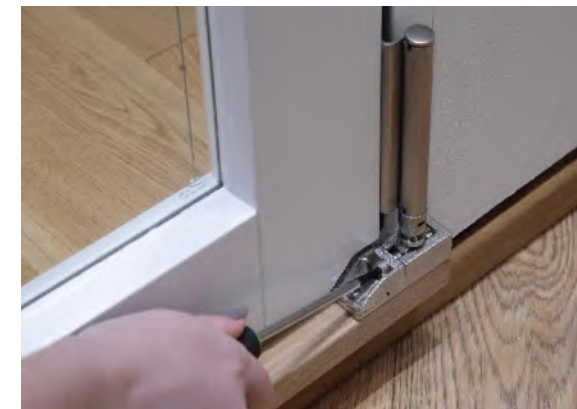
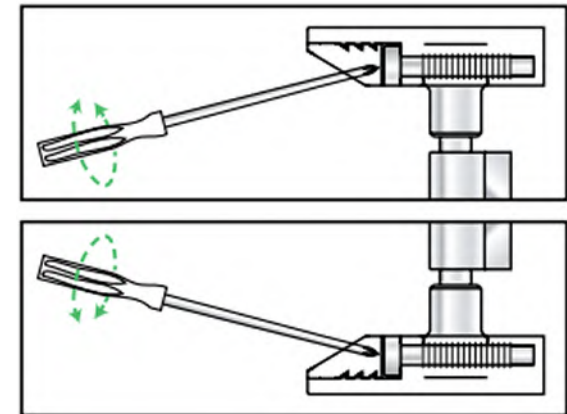

Internal Wooden French Door sets – Finesse and Urban ranges

All Vufold internal wooden French doors and frames, single glazed sealed units, and hardware components are guaranteed for a full 15 years against the occurrence of manufacturing faults, all subject to correct installation and regular maintenance and care in use as detailed below.



Door and frame components

All our timber components are manufactured using the latest technology to reduce warping or twisting. They are constructed using an engineered wooden core, solid wood lipping's and faced using real wooden veneers.

No two trees produce identical grains or colour of wood, and this adds to the beauty of a

natural product. We therefore cannot guarantee that all door and frame components will look exactly the same in grain and colour.

Veneers are natural products and prone to deterioration if not fully sealed with superior quality finish. If moisture penetrates the finish this may cause cracks to appear or splits.

Unfortunately, we cannot change the properties or performance of the timber components which are natural products. We cannot therefore accept claims for any variation in the components, or cracks or splits that may appear due to moisture going into the timber.

What is more, warping of wood is not a defect if it is not more than ¼ inch (6mm) when it is in its installed position.

Protective finish and maintenance

IMPORTANT: All internal Vufold door sets must be checked every 2 – 5 years for deterioration in the finish and re-coated as and when necessary. Moisture must not be allowed to penetrate the timber. The length of time between re-coating depends greatly on the environment / location the doors are installed in. The coating may require more regular attention if installed say between a kitchen and living area or separating a lounge and dining area with a log burner, or directly next to

a radiator due to regular varying temperature changes and moisture rich environments.

Finesse Oak Pre-finished (CPU) Door sets

The oak internal doors sets have been pre-finished with a clear polyurethane (CPU) finish. This finish offers good protection against natural moisture in the air and general temperature changes.

We do not recommend re-finishing with any finish other than polyurethane finishing system. If you are looking for a clear durable finish, we recommend using Dulux Trade clear polyurethane varnish in a satin finish. It is important that you have tested and checked that you are happy with your choice of finish before applying to your door set. Please note, even clear finishes will darken the timber from its original appearance.

Finesse White Primed Plus Door sets

The white internal door sets have been primed with a polyurethane satin wood finish. This finish is classed as a base coat finish; however, it still offers good protection against natural moisture in the air and general temperature changes.

The doors can be installed as supplied, however should you wish to apply a final coat, we recommend using a polyurethane finishing

system. The RAL (colour match) paint code for the white finish is 9016 Traffic White.

We cannot accept any claims for blemishes in the paint work as it is supplied as a base coat finish and may require a final topcoat, depending on personal preference.

Urban Black Primmed Plus Door Sets

The black internal door sets have been primmed with a polyurethane matt black wood finish. This finish is classed as a base coat finish; however, it still offers good protection against natural moisture in the air and general temperature changes.



The doors can be installed as supplied, however should you wish to apply a final coat, we recommend using a polyurethane finishing system. The RAL (colour match) paint code for the base coat black finish is 9011 Graphite Black.

We cannot accept any claims for blemishes in the paint work as it is supplied as a base coat finish and may require a final topcoat, depending on personal preference.

Finesse, and Urban Unfinished Door sets

All unfinished internal door sets must be fully finished according to our guidelines BEFORE the door set is installed. Failure to do so will invalidate the guarantee.

Please note that the use of steel wool or allowing steel or iron fragments to come into contact with the untreated oak timber or veneers may cause oxidation resulting in black staining.

Your internal unfinished door set(s) must be finished with an internal polyurethane varnish or paint in your preferred colour and gloss level. This should consist of a minimum of 3 coats to ALL faces and edges of the doors and frame components to ensure the product is fully sealed, including the tops and bottom edges of the doors.

If you are looking for a durable and more natural finish, we recommend using Dulux Trade clear polyurethane varnish in a satin finish. It is important that you have tested and checked that you are happy with your choice of finish before applying to your door set. Please

note, even clear finishes will darken the timber from its original appearance.

IMPORTANT: Do not use any oil, wax, quick drying products such as Ronseal or any finish other than a polyurethane finish as this will invalidate your guarantee.

Installation

Our ready-to-assemble internal wooden doors are supplied with all the essential items and virtually everything pre-machined. This design allows for simple on-site assembly by a competent DIYer or experienced trades person(s).

IMPORTANT: The frame needs to be installed perfectly square and level on all planes into the opening.

Single glazed units

All glass is supplied to The GGF (Glass and Glazing Federation) standards.

Tempered glass means it has been toughened to be up to five times stronger than normal glass. It is unusual to break such strong glass, but sharp objects hitting the glass at certain points can cause breakage. Tempered glass is also known as safety glass. This means that if it breaks it will shatter into smaller fragments which are less likely to cause injury, unlike non-

tempered glass which breaks into large, sharp fragments.

Glass must be regularly maintained and cleaned. This can be done using a mild solution such as washing-up liquid diluted in water. Do not use abrasive cleaning solutions as this may cause scratching.

Visual distortions caused by reflections in toughened glass are a natural phenomenon and not a fault.

Toughened, glass is acceptable if bubbles or blisters, fine scratches no more than 2.5cm long and / or minute particles are neither obtrusive nor bunched. The glass used is a processed glass therefore certain blemishes are unavoidable.

Hardware components

The hardware in your internal Vufold French door set can deteriorate from everyday use. That's why regular maintenance of your door hardware is important.

We require that the below minimum maintenance is carried out as often as necessary to prevent deterioration. As a guideline, we recommend that this maintenance is done every six months otherwise your guarantee will not be valid.

Hinges, and flush finger bolts

Using a microfibre cloth, wipe down the visible surfaces with warm soapy water and then rinse off by wiping with a clean, damp cloth. Applying a thin film of light machine oil or silicone spray, wiping with a dry cloth to remove any excess, will help to maintain the original lustre of the metal finish. Be careful not to get these liquids on the timber as this can cause staining.

The bolts should be maintained using silicone spray by directing the nozzle into the applicable areas. Always hold a cloth directly under the nozzle to prevent any over spray or liquid running onto the timber.

Door latch and handles

The handle and latch should operate just as smooth with the access door in the open position as what it does when it is fully closed.

It is important that if you feel any resistance when operating the handle, you do not continue to operate the doors as this may eventually cause the latch to fail and will invalidate your guarantee.

All moving parts should be lubricated using a silicone spray.

The handles should be regularly cleaned with a soft damp microfibre cloth to remove any dust or grime taking care not to scratch the surface.

If you experience problems opening and closing the doors, first eliminate the actual latch problems by opening the access door and pulling the handle downwards. If this can be done, the latch is operating normally, and the problem is likely to be due to incorrect door alignment / adjustment.

Door operational adjustments

When your doors are first installed, they may require some fine tuning to achieve a smooth operation. All our wooden internal door sets are supplied with easy to adjust hinges.

From time to time, due to changes in the temperature or because of general wear and tear in use, or if the door is difficult to operate, it may also be necessary to carry out some hinge adjustments.

If you experience any difficulty operating your doors, do not continue to use your doors as this may cause further issues and damages.

French Door side to side (width) adjustment

To adjust the spacing in-between the doors and the outer frame, locate the top adjustment screw, insert the 4mm Allen key provided; turn clockwise to position the doors closer together or anticlockwise to position further apart. Adjust each hinge as required to achieve even spacing.

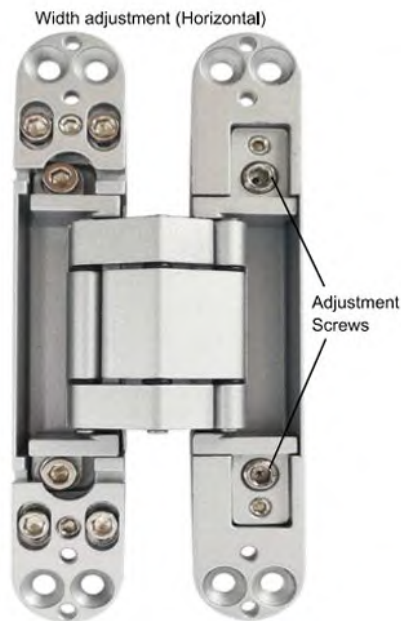

French Door in / out (depth) adjustment

To adjust the door to frame compression, locate the 2 clamping screws on both top and bottom hinges, insert the 4mm Allen key and turn anticlockwise to slightly loosen them off. Manually align the door into the desired compression and then turn all the clamping screws clockwise to re-tighten. Repeat the process on the adjacent door if required.

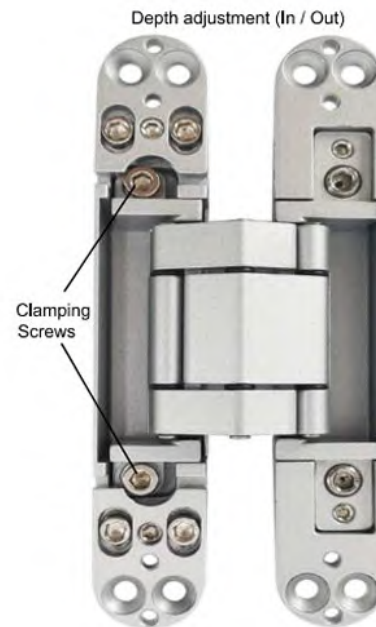

French Door up / down (height) adjustment

If you need to raise or lower the door(s), place air wedges or supports under the doors to take the weight off the hinges. Locate the 4 clamping screws and 2 adjustment screws on both top and bottom hinges, insert the 4mm Allen key into the clamping screws and turn anticlockwise to loosen them. Insert the 3mm Allen key provided into the adjustment screws and turn anticlockwise to loosen them. Manually raise or lower the doors by inflating or deflating the air wedges or adding or reducing the supports. Once the doors are in the desired position; retighten all clamping and adjustment screws).

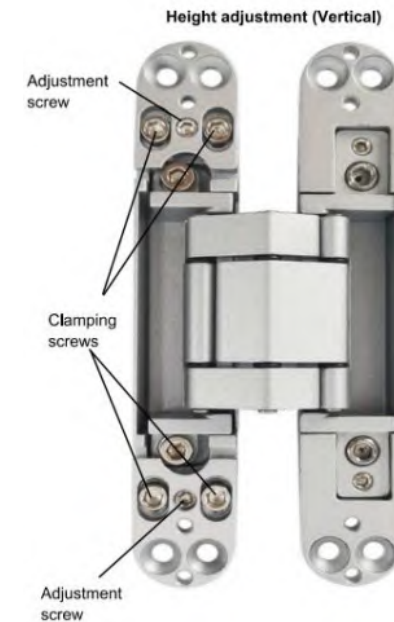

Internal Aluminium Door sets – Aluspace ranges

All Vufold internal aluminium doors, frames, fanlights, sidelights, powder coating finish, single glazed units and hardware components are guaranteed for a full 10 years against the occurrence of manufacturing faults, all subject to correct installation, regular maintenance, and care in use as detailed below.



Powder coating finish and maintenance

All our internal aluminium door sets are supplied fully powder coated providing a high quality and durable finish, unless otherwise specified.

Our standard colours are black - RAL 9005 and grey - RAL 7016. If you have selected an

alternative custom colour option and require the colour and RAL code, please contact a Vufold team member and they will provide this for you.

To maintain the powder-coated finish, wash regularly with soapy water and then dry off with a soft lint-free cloth.

We cannot accept any claims for damages, including scratches to the powder coating and aluminium reported 72 hours following delivery and / or after installation has commenced.

Installation

Our ready-to-assemble internal aluminium doors are supplied with all the essential items and virtually everything pre-machined. This design allows for simple on-site assembly by a competent DIYer or experienced trades person(s).

All glass will be supplied loose and will require installation by a competent trade's person experience with installing glass into doors and windows.

IMPORTANT: The frame needs to be installed perfectly square and level on all planes into the opening

Internal Aluminium Door sets – Aluspace ranges

Single glazed units

Loose glass should never be placed directly onto hard floors such as concrete, but should be placed on cardboard, sheeting or wooden batons, on edge rather than flat. The glass should be stored on its edge and at a 3 – 6 degree angle. Glass should not be stored horizontally or on top of each other and should not come into contact with anything harder than itself.

The glass must be inspected before being fitted to the door(s) and / or sidelight(s). We cannot accept any claims for scratched or damaged glass after 72 hours following delivery, and / or after installation has commenced.

Tempered glass means it has been toughened to be up to five times stronger than normal glass. It is unusual to break such strong glass, but sharp objects hitting the glass at certain points can cause breakage. Tempered glass is also known as safety glass. This means that if it breaks it will shatter into smaller fragments which are less likely to cause injury, unlike non-tempered glass which breaks into large, sharp fragments.

Glass must be regularly maintained and cleaned. This can be done using a mild solution such as washing-up liquid diluted in water. Do not use abrasive cleaning solutions as this may cause scratching.

Visual distortions caused by reflections in toughened glass are a natural phenomenon and not a fault.

Toughened, glass is acceptable if bubbles or blisters, fine scratches no more than 2.5cm long and / or minute particles are neither obtrusive nor bunched. The glass used is a processed glass therefore certain blemishes are unavoidable.

Hardware components

The hardware in your internal aluminium door set can deteriorate from everyday use. That's why regular maintenance of your door hardware is important.

We require that the below minimum maintenance is carried out as often as necessary to prevent deterioration. As a guideline, we recommend that this maintenance is done every six months otherwise your guarantee will not be valid.



Hinges, and flush finger bolts

Using a microfibre cloth, wipe down the visible surfaces with warm soapy water and then rinse off by wiping with a clean, damp cloth. Applying a thin film of light machine oil or silicone spray, wiping with a dry cloth to remove any excess, will help to maintain the

original lustre of the metal finish. Be careful not to get these liquids on the timber as this can cause staining.

The bolts should be maintained using silicone spray by directing the nozzle into the applicable areas. Always hold a cloth directly under the nozzle to prevent any over spray or liquid running onto the timber.

Door latch and handles

The magnetic latch will remain in the body of the lock until the door is closed and will automatically engage once it is aligned with the

receiver plate. Pulling the handle lever down will then retract the magnetic latch.

All moving parts should be lubricated using a silicone spray.

The handles should be regularly cleaned with a soft damp microfibre cloth to remove any dust or grime taking care not to scratch the surface.

It is important that if you feel any resistance when operating the handle, you do not continue to operate the doors as this may eventually cause the latch to fail and will invalidate your guarantee.

Blinds – Face Mounted Micro Pleat Blinds and Integral Slatted Blinds

Face mounted Micro Pleat Blinds

All Vufold Micro Pleat blinds are guaranteed for a period of 1 year against the occurrence of manufacturing faults, all subject to correct installation and regular maintenance and care in use as detailed below.

Rails and fabrics

Face mounted pleated blinds are supplied with either a grey, white, or brown rail and end caps, and are designed to be fitted to sit within the glazing bead of the individual door itself, but external to the glazing units. The pleated fabric is made from polyester and designed to help reflect solar gain. The fabric is designed to offer shade to the room and additional privacy. Please note, the blinds are not a black out and / or complete privacy blind.



Installation

We recommend installing the blinds once all building works have been completed to avoid any contamination from general build dust or debris or any wet works.

There are 2 types of fitting designs depending on your chosen door or window range. 'Screw fit' for wooden internal and external ranges and 'bead fit' for aluminium ranges. Both designs allow for simple on-site installation by a competent DIY'er or experienced trades person(s). A full fitting kit and installation instructions are provided.

Before commencing installation, please check you have received the correct type of fitting design, and all components are present and correct. Please ensure you have read the installation instructions supplied with your blinds.

Screw fit (wooden doors)

This design requires drilling the wooden glazing bead at the top and bottom corners as per the instructions provided. The rail is held in place by 2 screws in the upper glazing bead, and the tension cords are fixed in place using plastic grommets that slot into brass bushes in the lower glazing bead.

Before cutting any of the excess tensioning cords, please ensure you are fully happy with the fit and operation of your blinds.

Bead fit (aluminium doors)

Aluminium bead fit blinds require no drilling. They are supplied with top and bottom corner brackets which slot behind the rubber glazing seals and aluminium side extrusions for extra stability. The blinds are pre tensioned and the cords fit directly into each of the bottom brackets.



If the blinds need re-tensioning, please ensure you are operating correctly before trimming the excess cords.

Operation

The blinds are hand operated and pulled down / pushed up from the central part of the lower rail of the blind.

Do not operate the blinds by pulling the tensioning cords. If the cords are pulled from out of the bushes fitted to the bottom glazing bead, re-tie the knot and push it through the bushes, re-inserting the plastic cover gromet.

Due to the design of blind and glazing bead, spacing needs to be allowed between the fabric and the glazing bead, this is not a design fault but to allow for smooth operation.

Maintenance and cleaning

In normal use, our blinds can be cleaned using a soft brush, to remove dust and any insect particles that might have built up.

You can sponge clean the fabric if there is any fixed dirt or mark. Lightly dampen a sponge with a solution of lukewarm water and a gentle fabric soap and clean the blind fabric. This should be followed by a clean sponge rinse.

Damp blinds should be dried in the retracted position, to reinstate their pleats.

Integral Blinds

All Vufold Integral Venetian (inside the sealed glazing units) blinds are guaranteed for a period of 5 years, all subject regular maintenance and care in use as detailed below.

Slats

The venetian blinds are made up of metal slats coated in your selected colour.

Operation and adjustments

Move the external slider up or down to lower or raise the blinds, and to tilt the slats to the desired angle.

The integral blind raises and lowers using magnets if the external slider comes free from the glass you will not be able to operate the blind. If it has become disengaged, place the slider on the transparent guide at its lowest point and push the slider towards the top. As the slider moves upwards it will eventually come into contact with the internal magnet.

IMPORTANT: To achieve maximum attraction, you must move the slider to the very bottom position to fully engage the magnets, at the half engagement point you will hear/feel a click continue to move the slider downwards until

you hear/feel a second click. If the blind bottom rail becomes out of parallel, raise the blinds to the fully open position and then fully lower them. Repeat, if necessary, until the blinds adjust themselves back to level.

Maintenance and cleaning

Blinds located inside the sealed unit do not require any cleaning, however, the glass surface area must be cleaned on a regular basis to allow for smooth easy operation. Dirty glass can impede the movement on the magnetic controller, causing more force during operation and the potential to scratch the glass.



Making a Claim

If you believe you have a claim for a manufacturing defect under the guaranteed terms, we have a designated aftercare team on hand to assist you. Our aim is to operate our customer service system as efficiently as possible to reduce any stress involved. So that we can respond quickly to any customer problems, our customer service department is an integral part of our business, working under the guidance, and company policies and procedures as set out by the company directors. What's more, whichever member of our team starts to handle your problem or claim will see it through to completion, wherever possible.

We are a family run business who pride ourselves on both the quality of products and high-levels of service we offer, we try to deliver on our promise at every opportunity, however from time-to-time things can unfortunately go wrong. We will handle any queries you may have friendly and professionally, and whilst we understand it can be a stressful time during your project, we kindly request that you also remain courteous during any communications whilst we work to provide you with a resolution.

We operate a [zero-tolerance policy](#) for physical or verbal abuse, or aggressive behaviour towards any of our staff members, and including, but not limited to unreasonable demands. It will be the individual staff members discretion if they categorise their treatment falls under our zero-tolerance policy and have the right to make the decision to terminate telephone calls or not respond to emails, without notice, and / or not permit any further contact.

To make a claim, please contact our Customer Service Helpline on 01625 442 899 - selecting option two when prompted, or email: aftercare@vufold.co.uk. If you send us an email, it would also be helpful if you attach pictures or a video of the problem, as-well as internal and external pictures of the full product, as this will help us to solve the problem for you more efficiently.

Following receipt of your query, we will aim to respond and / or offer a resolution within 1 – 2 business days. For more complex queries, this may take longer, however, we will keep you updated throughout the process.

If replacement parts are required, for any stocked items they will be dispatched from our premises the following working day. For non-stocked items we will provide you with an

expected dispatch date and aim to get them to you at the earliest opportunity.

If replacement components are required for any made to order products, there will be extended lead times for these items.

We only use reputable delivery services, and ones we have an existing working relationship with. From dispatch of any replacement parts, delivery times can range from 2 – 5 working days, depending on the delivery service and your location. We will not accept requests for alternative delivery services other than the ones currently offered by Vufold.

For deliveries of replacement parts, we will only deliver under the same delivery terms as accepted with your original order. If you have arranged transportation of the goods to an alternative address, including but not limited to an address located outside of the UK, we will not accept liability for any forwarding costs.

From time to time, we may ask to visit your home to inspect the product(s). Naturally, this will be conducted in a professional and friendly manner, and by appointment with you. There will be an initial minimum charge of £250 depending on location before the visit can be arranged. If manufacturing defects are found to be the sole cause of the problem, this payment will be fully refunded. However, upon

inspection by the representative, the warranty claim is not caused by a manufacturing defect, but is caused by insufficient maintenance, poor or incorrect installation or operation, the charge will not be refunded. In every case, a full and detailed site visit report will be provided to you with recommendations of what action will be required to solve the problem.

If you are experiencing a lock related issue and the doors are stuck in the locked position, there will be an initial minimum locksmith call out charge of £174 depending on location, payable before the locksmith will attend. If the lock is found to be defective due to manufacturing, then the charge will be refunded in full. However, if the lock issue is not caused by a manufacturing defect but is caused by damage, poor or incorrect installation or misaligned doors the charge will not be refunded, and a report will be provided within 30 days after the inspection.

We will not be liable or accept any claims for losses or additional expenses incurred whether direct, indirect, or consequential, arising from any failure in the performance of our products or delays in supply, or if you have arranged for a third party to inspect and / or carry out any remedial work (that has not been previously reported and agreed by Vufold); including but not limited to obtaining any independent

specialist reports or arranging your own locksmith.

If your claim has been accepted and agreed by Vufold, any defective components proven to be faulty will be replaced free of charge. This guarantee covers for the issuing of replacement part(s) only and does not cover for any incidental expenses or losses; including but not limited to any additional works or labour required to fit the replacement part(s).

Any resolution offered by Vufold and accepted by you, is in full and final settlement of the problem experienced. If a replacement component has been issued, this will not extend the original guarantee period.

For further information please see our [Complaints policy and procedure](#)

Contact Us

Should you have any queries relating to any of the information set out in this Homeowners manual, please do not hesitate to contact a member of the Vufold team so we can assist you further.

Sales (new enquires)

Tel: 01625 442 899 (option 1)

sales@vufold.co.uk

Order Processing (pre-delivery and order enquires)

Tel: 01625 442 899 (option 2)

orders@vufold.co.uk

Customer Service (technical enquires and warranty claims)

Tel: 01625 442 899 (option 2)

aftercare@vufold.co.uk

[Vufold web site](#)

[Vufold installation videos](#)

Thank you again for choosing to purchase from Vufold

Vufold Limited, Unit A, Queens Court, Queens Avenue, Macclesfield, Cheshire. SK10 2BN



VUFOLD[®]

The difference is in the detail

VUFOLD LIMITED, UNIT A, QUEENS COURT, QUEENS AVENUE, MACCLESFIELD, CHESHIRE. SK10 2BN