

**EXTERNAL ALUMINIUM  
INLINE SLIDING PATIO DOORS**

Assembly Instructions  
Bespoke and Standard Sizes

**TRIPLE TRACK**

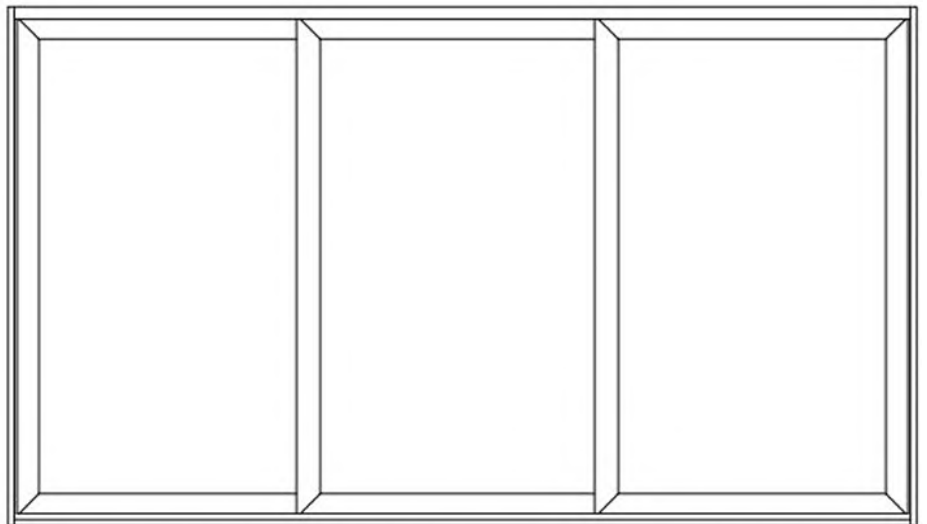

# About your Inline Sliding Patio Door Set

All products must be installed in accordance with accepted good trade practice (and in accordance with supplied instructions where applicable), and maintained in accordance with these procedures or else the warranty shall be void.

## Important Information

We recommend that a competent trades person installs this product. A single person must NEVER carry out the installation, as some of the components are heavy.

All of our external aluminium sliding doors and frames, powder coating finish, glazed units and hardware components are guaranteed for a full 15 years against the occurrence of manufacturing faults, all subject to correct installation, regular maintenance and care in use as detailed below.

### Powder Coating Finish and Maintenance

All our aluminium sliding door sets are supplied fully powder coated in a satin finish providing a high quality and durable finish, unless otherwise stated.

Our standard range of colours are Anthracite grey RAL 7016, Jet black RAL 9005 and Gloss white. If you have selected an alternative custom colour option and require the colour and RAL code please contact us.

To maintain the external aluminium powder-coated finish, wash regularly with soapy water and then dry off with a soft lint-free cloth. As a minimum, the external surfaces must be washed at least every three months, and monthly if within five miles of the sea or in an industrial area. Our general recommendation would be to wash the external aluminium every time you clean your windows, which should normally be more regularly than the minimum requirement.

The powder coating is not guaranteed unless the doors are installed at least 800 metres away from the sea.

We cannot accept any claims for damages, including scratches to the powder coating and aluminium reported 72 hours following delivery, and / or after installation has commenced.

## Installation

This door set is designed to be installed by competent trades persons with good knowledge and previous experience of installing sliding doors.

Our aluminium doors are supplied with all the essential items, most hardware factory fitted and everything pre-machined. This design allows for simple on-site assembly by experienced trades persons.

The outer frame needs to be securely fixed into the opening perfectly square and level on all planes. The aluminium sliding doors are bottom hung, the weight of the doors is supported via the sliding hardware and threshold. **Importantly: the threshold must be sufficiently packed to ensure there are no dips or rises along the full length of the bottom tracks. When fixing the frame head, ensure there is no bowing.**

## Glazing Units

To reduce carbon emissions from the home and to keep heating and cooling bills down, the government has recommended that all manufacturers use a special Low E thermal glass within the sealed units to comply with Building Regulations Part L.

This glass is coated with a special substance to comply with the above and occasionally, and in certain light conditions, may produce transient visual effects, this can sometimes look like a transparent film or haze, and make the glass appear cloudy. This is very infrequent and only affects a minority of door sets. As a company, we do have to comply with the new regulations which are for the benefit of all, and this is not a defect.

Due to demands for better thermal efficiency, it is normal for condensation to form on the outside of the glazing units, to the exterior side of the property. This demonstrates that the glass is performing as it should by reducing the transfer of heat from the internal side of the property to the external side of the property, this is not a defect. For any condensation forming to the inside of the property, this is normally due to high levels of moisture in the air and / or insufficient ventilation in the room, the moisture is then forming on the cold surface. If condensation is forming inside the glazing unit (between the panes of glass) it is likely that the glazing seal has been compromised.

Tempered glass means it has been toughened to be up to five times stronger than normal glass. It is unusual to break such strong glass, but sharp objects hitting the glass at certain points can cause breakage. Tempered glass is also known as safety glass. This means that if it breaks it will shatter into smaller fragments which are less likely to cause injury, unlike non-tempered glass which breaks into large, sharp fragments.

Laminated glass is also called safety glass and comprises of multiple layers of glass sandwiched together. Due to its high strength, this prevents the glass from breaking into large pieces. If the glass breaks, it will produce a 'spider web' effect similar to what is commonly seen in shattered car windscreens. Laminated glass will also increase the sound rating insulation.

Glass must be regularly maintained and cleaned to stop break down of the glass or seals. This can be done using a mild solution such as washing-up liquid diluted in water. Do not use abrasive cleaning solutions as this may cause scratching.

Visual distortions caused by reflections in toughened glazing units are a natural phenomenon and not a fault.

Laminated, toughened or coated glass is acceptable if bubbles or blisters, fine scratches no more than 2.5cm long and / or minute particles are neither obtrusive or bunched. The glass used in sealed units is processed glass, therefore

## About your Inline Sliding Patio Door Set (cont)

certain blemishes are unavoidable. More blemishes may be visible in laminated glass due to its layered construction.

For carrying out glass inspections, stand at least 3 metres away from the glazing, view at a 90 degree angle and look directly through the sealed unit(s). The glass must be viewed in natural daylight but not with the sun directly on it. Any moisture must be removed from the surface of the glass before inspecting.

### Hardware Components

The exterior hardware in your sliding door set can deteriorate from everyday use, and also because of the weather and local environment. That's why regular maintenance of your door hardware is even more important if you live in severe environments like coastal / marine areas and some industrial locations.

We require that the below minimum maintenance is carried out as often as necessary to prevent deterioration. As a guideline, we recommend that this maintenance is done every three months if you live in a marine environment, or every six months if you live in a more general location, otherwise your guarantee will not be valid.

### Tracks and bearings

Once your installation has been completed, and before fully operating your door set, please carefully remove any debris / swarf from the top and bottom tracks to ensure nothing comes into contact with any moving components. After cleaning the tracks, using a microfibre cloth, apply a small amount of lubricant such as a silicone spray to the inner lip of each side of the track.

Extra lubricant can be added around the bearings. Adding lubricant in this way reduces wear, improves smoothness and gives additional protection against corrosion of track and bearings.

### Locks and handles

Your inline sliding door is opened and closed by raising and lowering the handle, and locked using the key. The lock should operate just as smooth with the access door in the open position as what it does when it is fully closed. It is important that if you feel any excessive resistance when operating the handle, you do not continue to operate the doors as this may eventually cause the lock to fail and will invalidate your guarantee.

All moving parts should be lubricated using a silicone spray. The handles should be regularly cleaned with a soft damp microfibre cloth to remove any dust or grime taking care not to scratch the surface.

If you experience problems with locking or unlocking the doors, first eliminate actual locking problems by opening the access door and pulling the handle downwards and then turning the key. If this can be done, the lock is operating normally, and the problem is likely to be due to incorrect door alignment / adjustment.

### Door Operation

Sliding door sets have become more popular due to customers wanting to maximise the size of each glazed panel, giving more light and fewer interrupted views. The bigger the glass area the heavier the individual panels will be, which in turn will cause extra resistance when operating the heavier doors.

All our aluminium sliding door sets have been pre-assembled in our factory. They are installed into a steel framed testing rig where they are fully operated, including checking the doors lock and unlock smoothly. The door sets are then part dismantled, packaged up ready for dispatch and onsite assembly.

If you experience any difficulty operating your doors, including opening, closing, sliding and locking, do not continue to use your doors as this may cause further issues and damages. Please contact a member of our customer service team so we can assist you further.

## Introduction to Assembly - Quick Guide

How your aluminium inline sliding patio door set arrives on site can vary however in the main they will arrive as follows;

### Outer Frame - (built up)

Supplied with the outer frame built up and the doors fully assembled within the frame, unglazed. Optional drip cill's and frame head add-ons will be supplied loose, and strapped to the frame head for transportation.

### Outer Frame - (kit form)

Supplied with the outer frame knocked down, doors separate and unglazed. Optional drip cill's and frame head add-ons will be supplied loose and packed with the frame pack for transportation.

### Glass

The glazing units will be supplied loose, for your fitter to balance on site.

These guidelines are to ensure the safety of those handling our products, as well as ensuring they arrive to you in the best possible condition. Our team will contact you in advance of dispatch to discuss your individual delivery arrangements.

These fitting instructions will cover the installation of both standard sized and bespoke Inline sliding door sets, with sections covering assembly of frames that are supplied in kit form and built up, with door leafs that are unglazed, supplied with glass loose.

**IMPORTANT- Glass lifters / suction cups must be used during the installation of these doors (not supplied)**

## Contents

**DOORS-** Supplied unglazed, pre-fitted within the outer frame or loose, depending on order.

**OUTER FRAME-** Comprises of frame head, jambs and threshold. Supplied built-up or kit form depending on order.

**GLASS-** Supplied loose.

**CILL-** Supplied loose / strapped to the outer frame head.

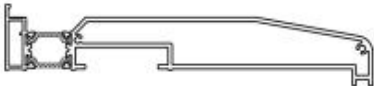

**CILL END CAPS & FIXINGS-** Supplied loose / located inside the frame.

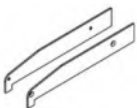

### OPTIONAL EXTRAS

**TRICKLE VENTS & FRAME HEAD ADD-ON** - Supplied pre-fitted to the frame head add-on which is fitted to the frame head.

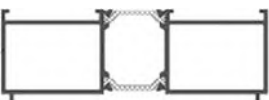



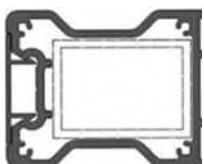

**STRENGTHENING BAR- OPTIONAL** - Supplied fitted to the external face of the door where specified.



## Contents (cont)

### FIXINGS

#### FIXING KIT-

- HSS drill bit 6.5mm x 100mm - Qty 1 
- SDS Masonry drill bit 6.5mm x 160mm - Qty 1 
- 1/4 hex T30 bit - Qty 1 
- 92mm direct frame fixing screws - Qty 30 
- 4mm Allen key - Qty 1 

#### SUPPLIED LOOSE-

- Low modulus silicone - Qty 1
- Assorted packers - Qty 1 bag
- Bridging packers - Qty 2 per door
- Drainage cover caps - Qty depending on order
- Wedge gasket - Qty 1 roll



#### UNASSEMBLED FRAMES ONLY-

- Corner cleats - Qty 8

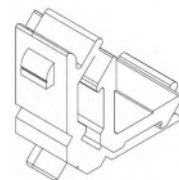

## Preparing the site

### Brickwork opening:

When preparing the site please prepare the brickwork opening to be 10mm more in height and width than the outside assembled frame size of the Inline sliding door frame.

It is essential that all 4 internal surfaces of the brickwork be levelled before installation. Please ensure that all dimensions are correct for installation before proceeding, as the outer frame must be installed square and level into the opening.

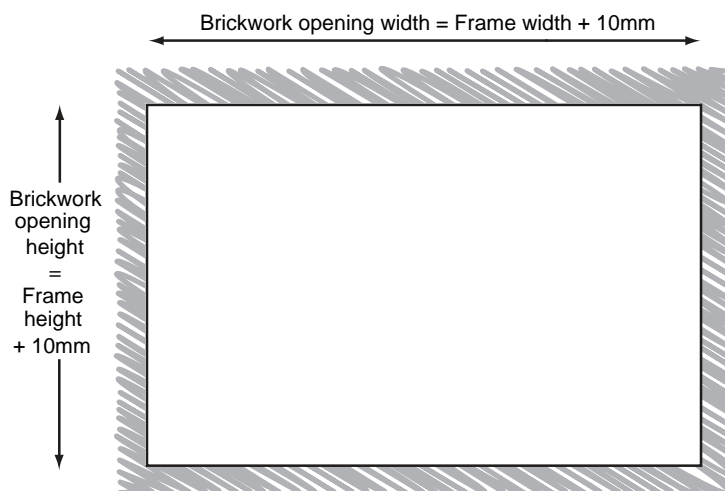

Dimensions for standard sized Inline Sliders

Outer Frame (Width x height)	Brickwork Opening (Width x height)
2990mm x 2090mm	3000mm x 2100mm
3590mm x 2090mm	3600mm x 2100mm
3990mm x 2090mm	4000mm x 2100mm
4590mm x 2090mm	4500mm x 2100mm
4990mm x 2090mm	5000mm x 2100mm

As standard, our triple track Inline slider will be a 3 door 'Triple Opening' sliding door, meaning all 3 doors can be opened. Other configurations can be special ordered.

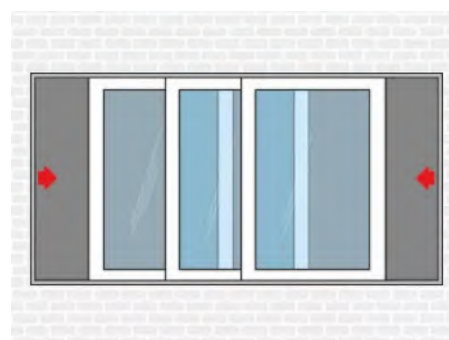

TRIPLE OPENER (viewed from outside)

## Fitting the drip cill

The easiest way to install the frame with a cill is to level the cill in the opening first, temporarily fixing this in place and then lift the assembled frame on top.

If you have selected an Inline sliding door with a drip cill, first place the cill into the bottom of the brickwork opening ensuring the frame jambs will sit a maximum of 5-20mm back from the face of the brickwork. **Most importantly the frame jambs must be securely fixed, the bottom track must be fully supported from front to back, and levelled without dips or raises, with the cill overhanging the brickwork for drainage.**

Using a long spirit level, ensure the cill is sitting level in the opening, using the packers supplied if needed to level it. As this door is bottom rolling, it is vitally important the cill is fully supported from front to back. Packers can be kept in place using the silicone supplied.

Once the cill position is level and fully supported, use the HSS drill provided to drill a hole at each end of the cill through the thermal break. Use the SDS masonry drill supplied to drill through these holes into the masonry. Finally fix the cill in place using 2 of the direct frame fixings supplied, ensuring they are silicone dipped.

Indicates silicone

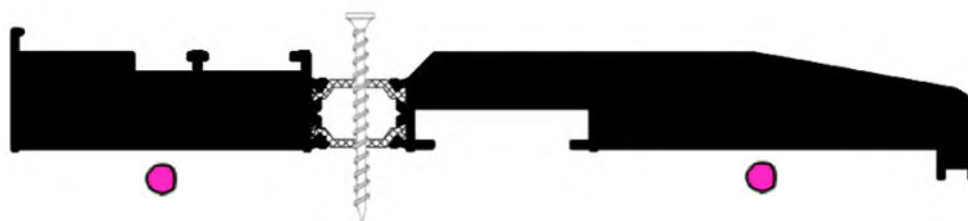



## Assembling the outer frame



If your outer frame has been supplied in kit form, lay the 4 pcs of frame on the floor on top of cardboard or similar protective covering to prevent damage to the aluminium powder coating.

Take care to ensure you've correctly assembled the frame. The sections will be labelled during production as A/A, B/B, C/C and D/D and should be assembled so accordingly.

Internal side

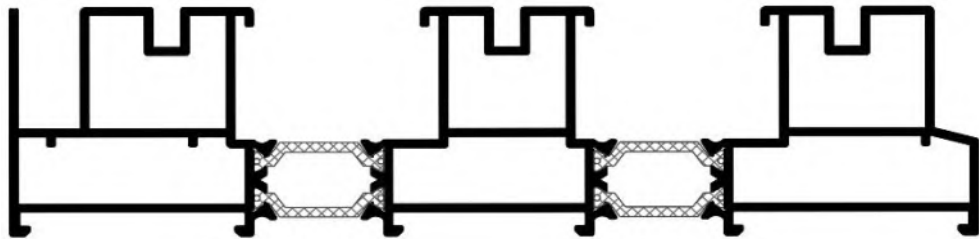

External side

Firstly apply silicone sealant to all touching faces.



Example shows double track sections

Its important to seal the bottom profile at both ends to prevent water from draining into the cleats.



Example shows double track sections

Assemble the complete frame by fixing the jambs to the head and bottom rail using the corner cleats provided, **ensuring the lugs locate when inserting them into the sections.**

Finally, in stages tighten with the 4mm Allen key provided. **IMPORTANT:** Take care to ensure the drainage channels remain clear.



Example shows double track sections

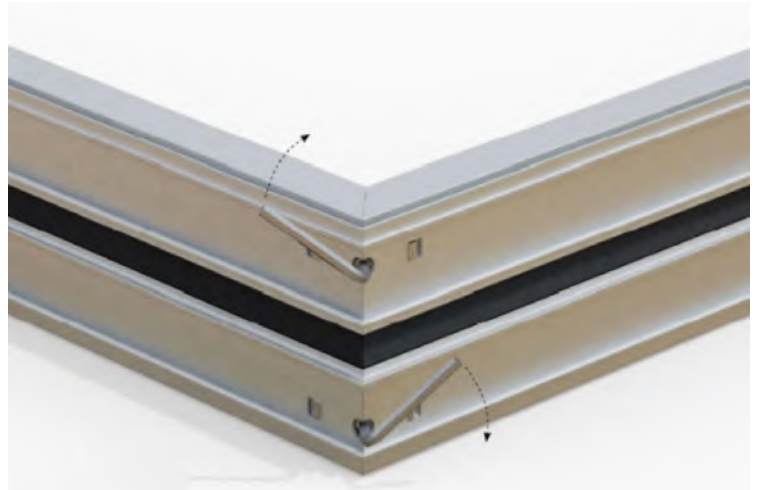

Example shows double track sections

## Assembling the outer frame (cont)



Example shows double track sections

Check the join, remove excess sealant and repeat the process.

Ensure you seal the access holes to prevent water entry.

## Optional trickle vent add-on

If you have chosen to add trickle ventilation to your sliding door, these are supplied in an aluminium add-on which sits on top of the frame head. The add-on will be supplied fitted when it arrives to you, the trickle vents will be attached to the add-on and the ventilation holes pre-machined.

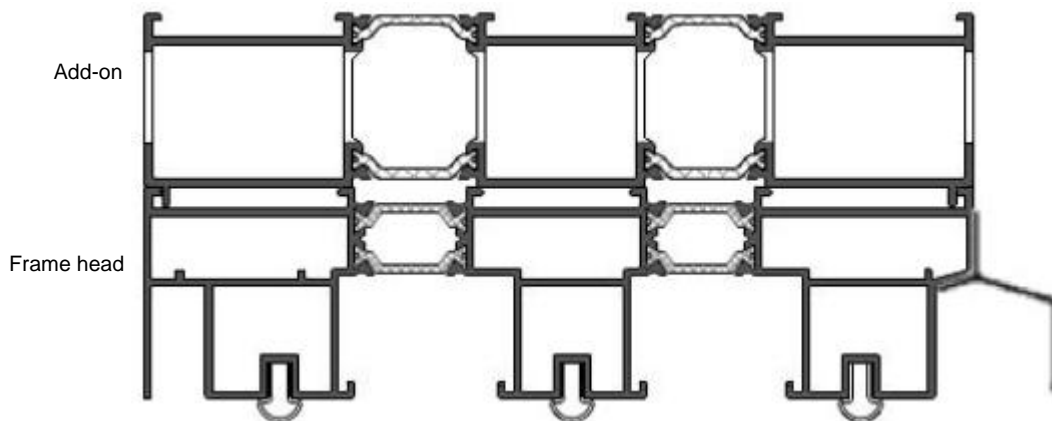

Ensure the add-on is joined to the frame head so the canopies of the trickle vents are on the external side of the frame.



Vent fits to inside face



Canopy fits to outer face



## Installing the assembled frame

Please refer to the below for diagrams detailing the dimensions of the frame and cill sections, when considering finished floor heights.

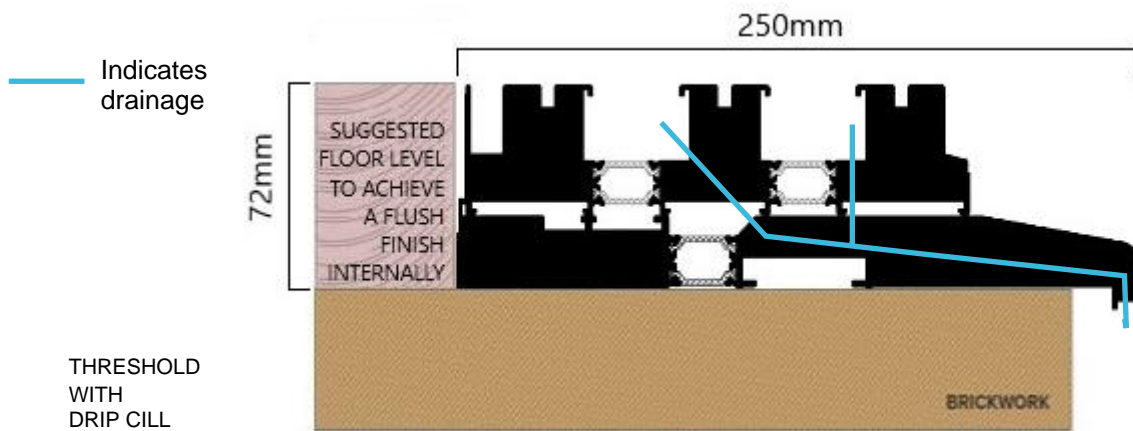

The outer frame should be positioned in the brickwork opening with the jambs to the outer edge, up to a maximum 5mm - 20mm back from the face of the brickwork. **Most importantly, the frame jambs should have a secure fixing, the bottom track should be fully supported from front to back, levelled without dips or raises, with the cill (if selected) overhanging the brickwork.**

Run a bead of silicone the length of the threshold, as shown below.

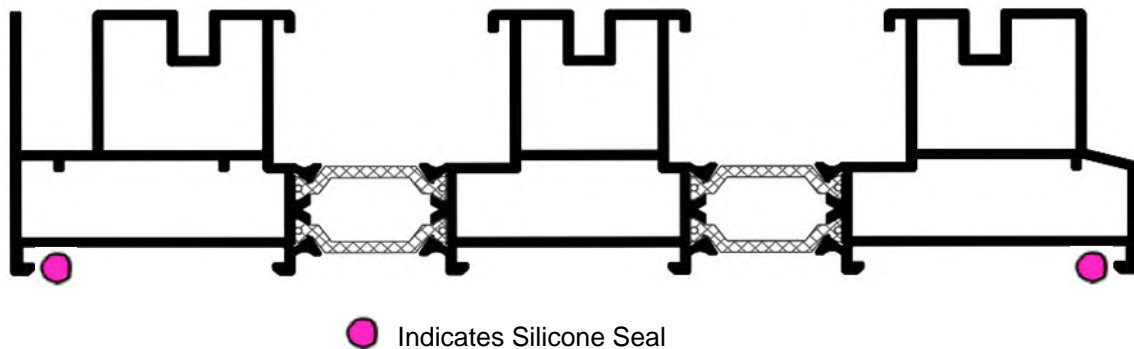

**IMPORTANT:** It is critical that the frame is fitted square and level, and checked using a laser level.

### Built-up frames

Our standard sliding 3 door sets are supplied with all doors opening, with the left-hand door being the master door. The master door runs on the inside track when viewed from the outside. For fully assembled frames, the doors will be installed into the frame. They will require fixing into the opening and glazing.

Some bespoke configurations may be supplied with track cover plates.

Any track cover plates supplied temporary fitted will need to be removed to allow access to the fixing points by simply clicking them in and out of the frame sections.



## Installing the assembled frame (cont)

If you have ordered 1 sliding and 1 fixed panel. The fixed panel has been temporarily fixed into the frame at the side and bottom. Remove the temporary fixing screws and slide the fixed panel away from the frame, to then allow you to secure the frame into the opening. Once the frame has been secured into the opening, refit the side and bottom screws into the original fixing points / holes, ensuring the bottom fixing screws have been silicone dipped.

If you have already fitted a drip cill into the bottom of the brickwork opening, take care when lifting the outer frame on top not to damage the drip cill. You should have already levelled and fully supported your drip cill, meaning the threshold should automatically sit level on top. Where no drip cill is being used, using the packers supplied, level the frame starting at the bottom and insert the first packer **DIRECTLY UNDER THE FRAME JAMB** starting at whichever side of the frame looks highest.

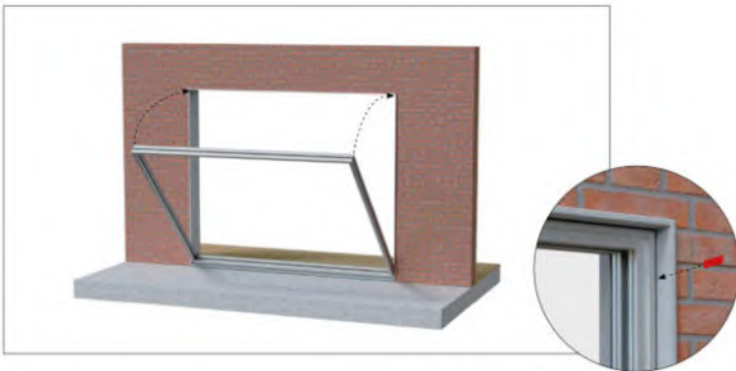

Continue to pack all around the frame. Ensure the top and bottom tracks do not bow in any direction, the internal frame dimensions are consistent, and the structural opening does not transfer any load onto the frame.

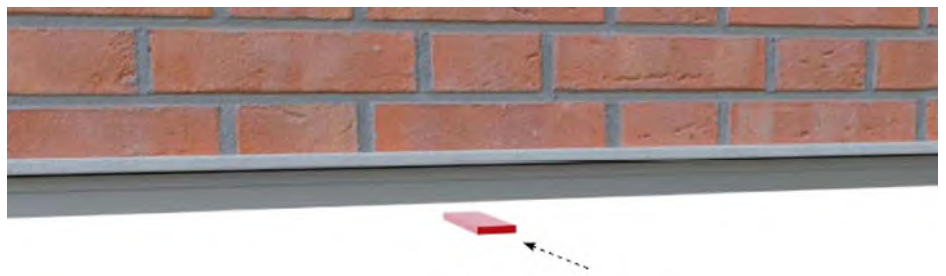
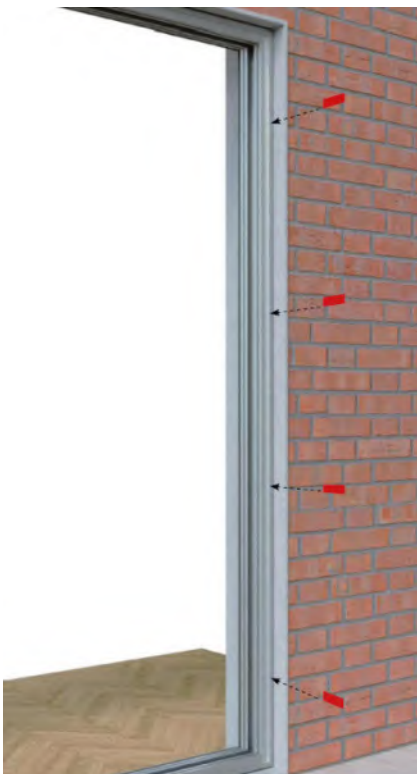

## Installing the assembled frame (cont)

Continually check the frame using a long spirit level as you go. It is very important the frame is installed into the brickwork opening completely upright, square and level in every plane. Measure diagonally across the frame and ensure the measurements are the same.

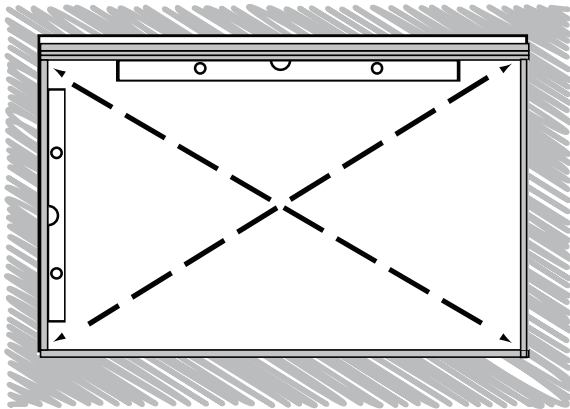

The diagonals must be the same

**Do not proceed unless you are 100% happy the frame is in upright, square and level in every plane and checked using a laser level.**

**The door set uses a bottom rolling system so it is vitally important the bottom frame section (and drip cill if selected) is level and adequately supported from front to back, without dips or raises, all the way along using packers as necessary.**

When the frame is in the opening square and level, drill fixing holes 150 - 200mm from each corner and then at maximum 600mm intervals. Use the HSS drill provided to drill the frame sections and the SDS masonry drill for the lintel / brickwork.

When the frame is in the opening square and level, drill fixing holes 150 - 200mm from each corner and then at 600mm centres. Use the HSS drill provided to drill the frame sections and the SDS masonry drill for the lintel / brickwork.

Finally fix in place with the direct frame fixings and T30 bit provided, through the thermal break.

**IMPORTANT: Ensure the fixings in the bottom section are silicone dipped.**

Frame head & jamb fixing point

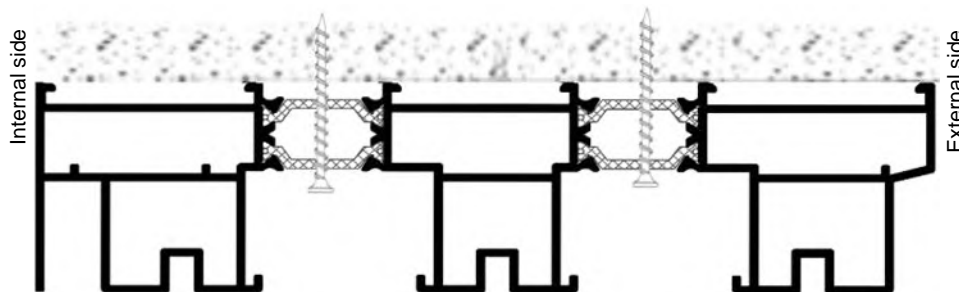

Threshold frame fixing point

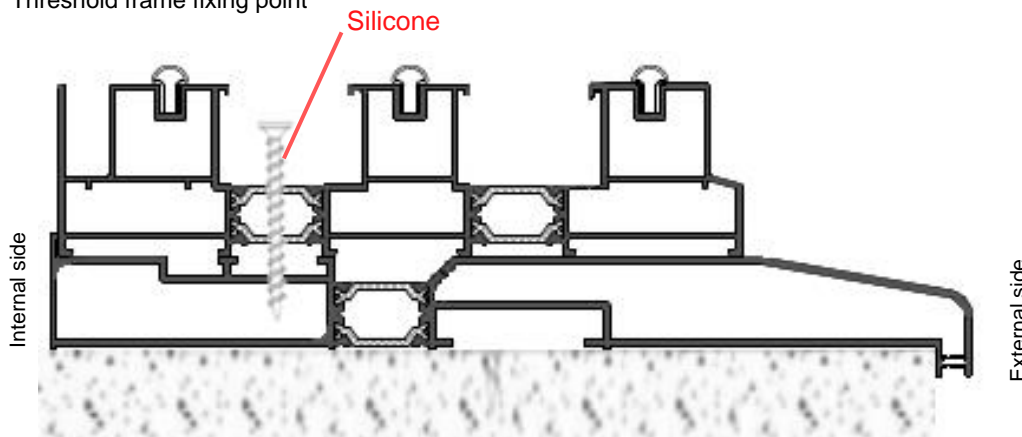

To fix through the frame jambs, again drill fixing holes 150 - 200 mm from each corner and then 600mm centres. Use the HSS drill provided to drill the frame sections and the SDS masonry drill for the brickwork.

## Installing the doors into the installed frame

### Kit-form frames

If your frame has been supplied in kit-form and has now been assembled, install the doors into the frame. The temporary fixed glazing bead will be located to the inside of the doors.

All drawings and instructions are looking from the outside towards the inside here after.

Working from outside, carefully lift the master door (configured as per your order) onto the inner most track of the frame head, and swing the bottom of the door over the bottom track, ensuring the wheels are correctly located onto the inner track. You may find it easier to install the door into the middle of the frame and then slide it to the correct side.

Some configurations may be supplied with track cover plates. Any track cover plates supplied temporary fitted will need to be removed to allow access to the fixing points by simply clicking them in and out of the frame sections.

Repeat with the second sliding door panel, and finally the third door.

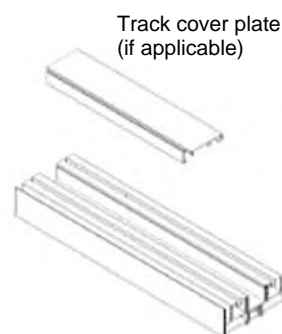

## Optional strengthening bar

If the optional strengthening bar has been chosen (custom orders only) for reinforcement, it will be pre-fitted during production and by default, will be on the outer face of the door set unless specifically requested otherwise during ordering.

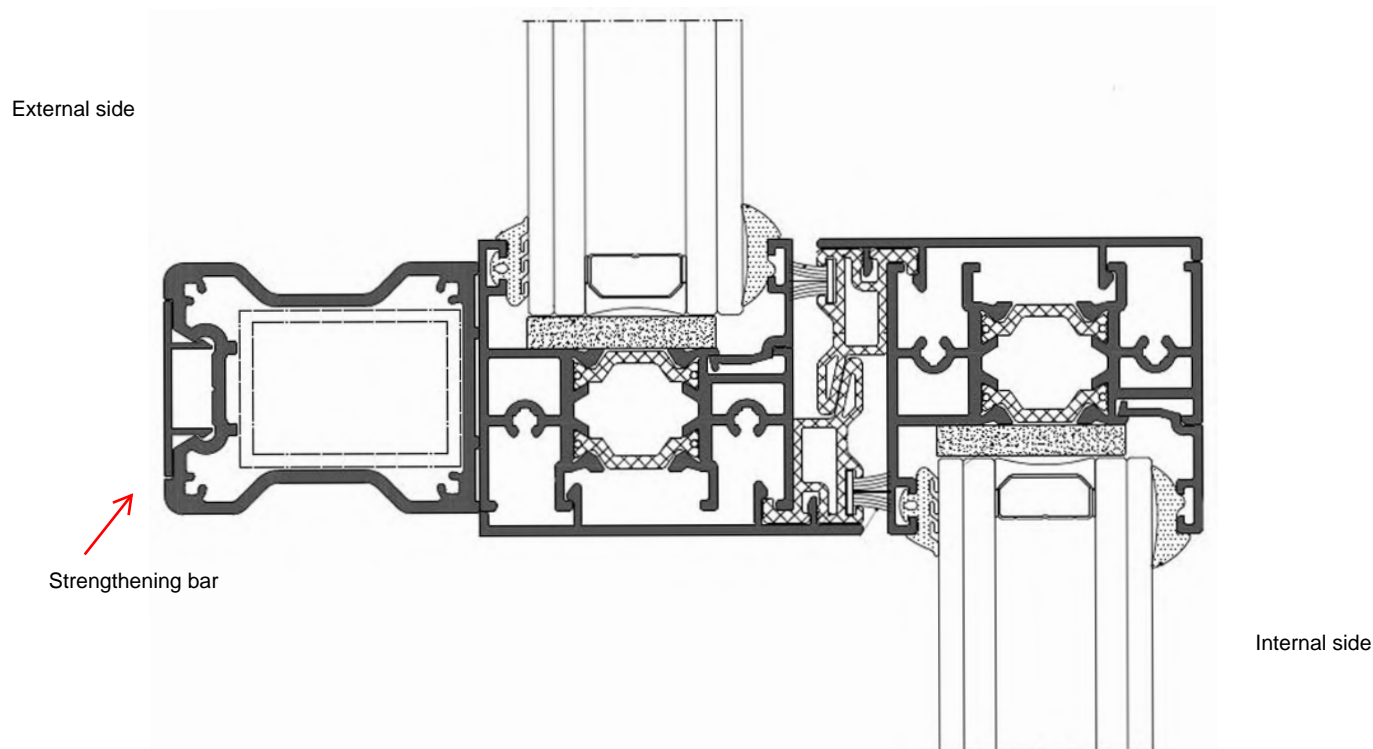

# Glazing the doors

Our inline sliding doors are supplied with the glazing loose, for the fitter to glaze on site.

**IMPORTANT:** Glass lifters / suction cups must be used during the installation of these doors. The doors must be glazed / toe and healed by an experienced glazier. Do not proceed with the glass installation if you are not experienced in glazing as this can affect the overall operation.

The below is a general guide and recommended packer placement; however, it is the glaziers responsibility to ensure the glass has been packed and supported sufficiently with the correct type and placement of bridging and glazing packers.

Place 2 black bridging packers at the bottom of each door; approximately 100 - 150mm from the door edges, securing in place with some silicone.

Using glass lifters / suction cups, fit the loose glass into the rebate on the door, sitting the glass on top of the bridging packers and then securing in place at the top and sides with wedge glazing packers provided.

## Doors / sliding panels

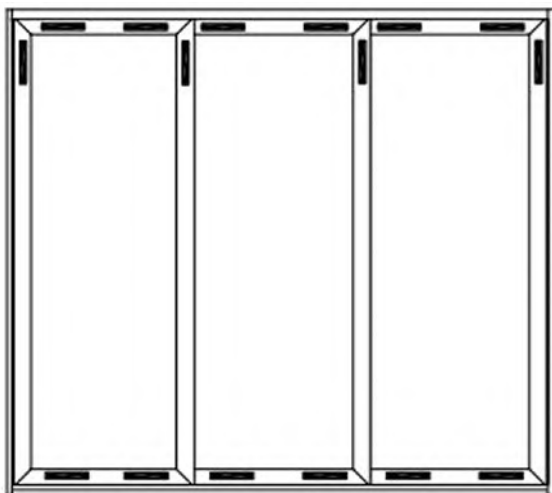

Perimeter support wedge packers

Bridge packers

Wedge glazing packer



## Fixed / non sliding panels

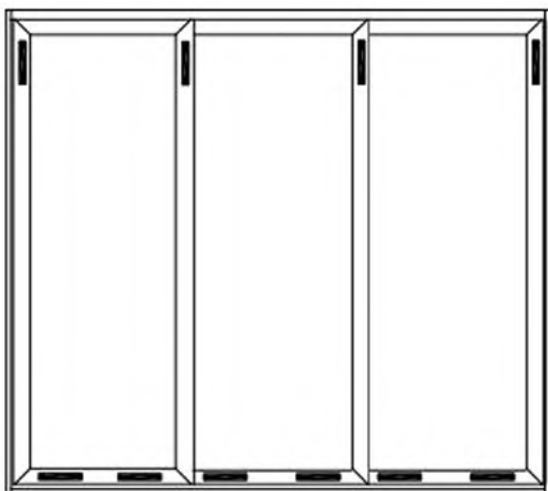

Perimeter support wedge packers

Bridge packers

Bridge glazing packer





## Glazing the doors (cont)

Locate the internal glazing bead and clip this into position, starting with the top and bottom first and then the sides. Finally, insert the internal wedge gasket to secure. The gasket will require compressing and pushing in to locate correctly. It is recommended that a glazing paddle is used to help with compression.

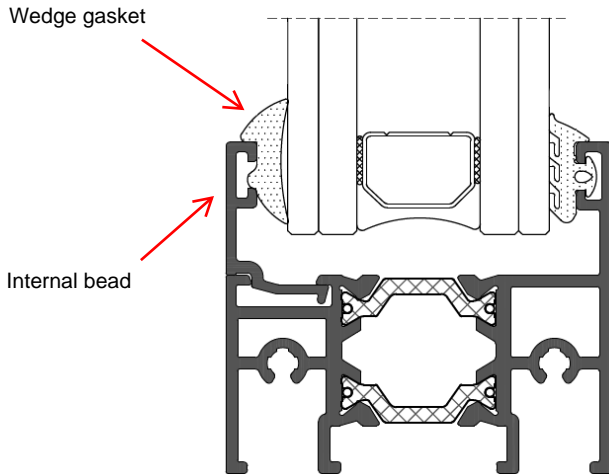

## Operation of your Inline sliding patio door

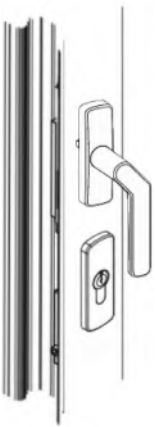

In the closed position, the handle of your Inline sliding patio door will be facing down as shown opposite. The handle lifts to 90 degrees in the open position.